

Slewing rings

Catalogue 404





For many years, Schaeffler has made a decisive contribution to the development and current level of rolling bearing technology, particularly through its compact needle roller bearings, high load capacity cylindrical roller bearings and its diverse range of track rollers for rotary and linear motion.

INA slewing rings are also known worldwide as premium products in the field of rolling bearing technology. These machine elements have proved themselves many times over; they have high load carrying capacity, a versatile range of applications and are highly cost-effective. Due to their design, a single bearing can reliably support radial, axial and tilting moment loads. It is therefore possible in many cases to replace bearing arrangements comprising a combination of radial and axial bearings by a single bearing. This reduces, in some cases considerably, the costs and work required in the design of the adjacent construction and the fitting of bearings.

Slewing rings are sealed on both sides, lubricated with a high quality grease, can be relubricated via lubrication nipples and are particularly easy to fit. The bearing rings are supplied without gear teeth or, in order to achieve simple drive solutions, are available with external or internal gear teeth.

INA slewing rings are designed as:



- four point contact bearings
 - these slewing rings without preload are robust and proven under very demanding operation; they place only slight demands on the flatness and perpendicularity of the adjacent construction
 - they are suitable for applications with low requirements for accuracy and rigidity of the bearing arrangement, for example in simple metalworking machines, wind power equipment and construction machinery
- crossed roller bearings
 - these preloaded slewing rings can support higher loads than four point contact bearings. They have proved themselves particularly where bearings are subjected to high radial forces and moderate axial and tilting moment loads
 - they are suitable for applications with uniform running free from stick-slip, low rotational resistance and high requirements for axial and radial runout accuracy and rigidity, for example in robots, handling systems and machine tools.

Catalogue 404 presented here gives comprehensive information on the reorganised standard range of these slewing rings.

Any information in editions that does not concur with the information in this edition is therefore invalid.

Product range

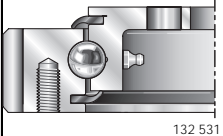
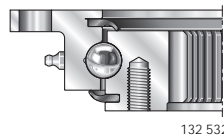
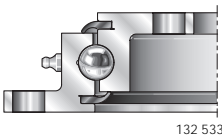
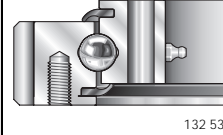
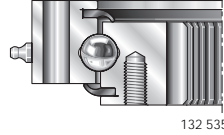
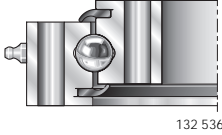
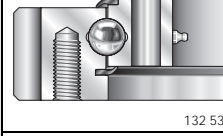
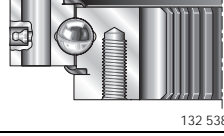
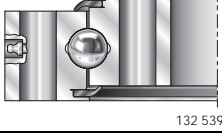
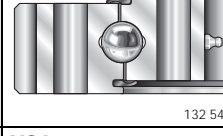
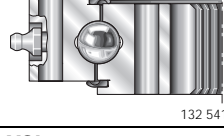
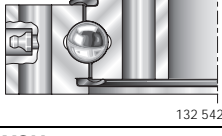
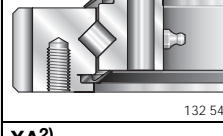
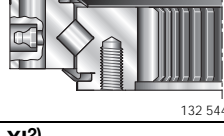
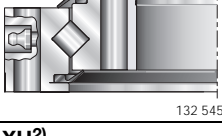
Overview/selection scheme

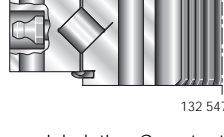
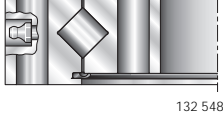





			Characteristics	Rolling element pitch circle diameter	Load carrying capacity ⁴⁾	
				D_M	radial stat. kN	axial on both sides stat. kN
Slewing rings						
Four point contact bearings	VLA 20  132 531	VLI 20  132 532	VLU 20  132 533	from 414 mm to 1094 mm	from 110 to 290	from 295 to 770
	VSA 20  132 534	VSI 20  132 535	VSU 20  132 536	from 414 mm to 1094 mm	from 248 to 660	from 560 to 1490
	VSA 25  132 537	VSI 25  132 538	VSU 25  132 539	from 755 mm to 1055 mm	from 1010 to 1410	from 2250 to 3150
	VA²⁾  132 540	VI²⁾  132 541	VU²⁾  132 542	VA = 188 mm to 309 mm VI = 288 mm to 420 mm VU = 179 mm to 680 mm	See dimension table	
	XSA 14  132 543	XSI 14  132 544	XSU 14  132 545	from 414 mm to 1094 mm	from 250 to 670	from 520 to 1360
	XA²⁾  132 546	XI²⁾  132 547	XU²⁾  132 548	XA = 235 mm and 352 mm XI = 288 mm XU = 77 mm to 515 mm	See dimension table	

1) Special design with Schaeffler special plating Corrotect®.

2) For further designs see *dimension table*.

3) Values for slewing rings with standard clearance.

4) The values relate to the smallest and largest rolling element pitch circle diameter D_M per series.

Requirements for adjacent construction	Maximum circumferential speed with grease lubrication ³⁾	Internal clearance			Sealed on both sides	Operating temperature	Anti-corrosion protection ¹⁾	Features See page
		matched	selectable	preloaded				
low	2 m/s ($n \cdot D_M = 38\,200$) for brief periods up to 2,6 m/s ($n \cdot D_M = 49\,700$)		<input type="checkbox"/>		<input type="checkbox"/>	-25 °C to +80 °C	<input type="checkbox"/>	 48
low	2 m/s ($n \cdot D_M = 38\,200$) for brief periods up to 2,6 m/s ($n \cdot D_M = 49\,700$)		<input type="checkbox"/>		<input type="checkbox"/>	-25 °C to +80 °C	<input type="checkbox"/>	 48
low	4 m/s ($n \cdot D_M = 76\,400$) for brief periods up to 5,2 m/s ($n \cdot D_M = 99\,500$)	<input type="checkbox"/>			<input type="checkbox"/>	-25 °C to +80 °C	<input type="checkbox"/>	 48
low	4 m/s ($n \cdot D_M = 76\,400$) for brief periods up to 5,2 m/s ($n \cdot D_M = 99\,500$)		<input type="checkbox"/>		<input type="checkbox"/>	-25 °C to +25 °C	<input type="checkbox"/>	 48
moderate	2 m/s ($n \cdot D_M = 38\,200$) for brief periods up to 2,6 m/s ($n \cdot D_M = 49\,700$)			<input type="checkbox"/>	<input type="checkbox"/>	-25 °C to +80 °C	<input type="checkbox"/>	 78
moderate	2 m/s ($n \cdot D_M = 38\,200$) for brief periods up to 2,6 m/s ($n \cdot D_M = 49\,700$)			<input type="checkbox"/>	<input type="checkbox"/>	-25 °C to +80 °C	<input type="checkbox"/>	 78

Contents

Page	
	<i>Product range</i>
2	Overview/selection scheme
6	Product index
7	Index of suffixes
8	Ordering designation
9	Ordering example, ordering designation
10	Symbols and units
	<i>Technical principles</i>
12	Load carrying capacity and life
12	Static load carrying capacity
12	Definition of static load carrying capacity
12	Checking the static load carrying capacity
15	Calculation example
16	Dynamic load carrying capacity
16	Definition of dynamic load carrying capacity
16	Definition of basic rating life
16	Determining the basic rating life
18	Influences on the operating life of slewing rings
19	Calculation example
20	Fixing screws
20	Static and dynamic load carrying capacity
20	Conditions for checking load carrying capacity
20	Static limiting load diagrams
21	Static load carrying capacity of fixing screws
21	Dynamic load carrying capacity of fixing screws
22	Rotational resistance
24	Gear teeth
26	Lubrication
27	Grease lubrication
27	Criteria for grease selection
30	Initial greasing
30	Lubrication intervals
31	Grease operating life
31	Relubrication procedure
33	Oil lubrication
34	Sealing of the bearing arrangement
34	INA seal profiles

Page	
36	Design of bearing arrangements
36	Sealing of the bearing position
36	Fixing screws
37	Location by cylindrical pot
37	Dimensioning of the flange thickness
38	Permissible flatness and perpendicularity deviation of the adjacent construction
39	Fitting
40	Delivered condition of slewing rings
41	Hardness gap on slewing rings
42	Provision of fasteners
42	Securing of screws
42	General safety and operating guidelines
43	Fitting of slewing rings
43	Location of slewing rings
44	Checking and adjustment of tooth flank backlash
44	Measuring the tilting clearance
45	Checking the function
46	Tightening torques and fitting preload forces for fixing screws
	Product range
48	Four point contact bearings
48	Features
50	Accuracy
52	Dimension tables
78	Crossed roller bearings
78	Features
80	Accuracy
82	Dimension tables
	Appendix
94	Application examples
	Other products
98	Crossed roller bearings for high precision applications

Product index

sorted alphanumerically

Features Page	Tables from page	Type	Description
-	70	VA	Four point contact bearing, external teeth, sealed, selectable internal clearance, lubrication nipple on circumference of untoothed ring
-	72	VI	Four point contact bearing, internal teeth, sealed, selectable internal clearance, lubrication nipple on circumference of untoothed ring
-	74	VU	Four point contact bearing, without teeth, sealed, selectable internal clearance, lubrication nipple on outer ring circumference
48	52	VLA 20	Four point contact bearing, light series 20, external gear teeth, selectable internal clearance, sealed, lubrication nipple on circumference of ring without teeth
49	54	VLI 20	Four point contact bearing, light series 20, internal gear teeth, selectable internal clearance, sealed, lubrication nipple on circumference of ring without teeth
49	56	VLU 20	Four point contact bearing, light series 20, without gear teeth, selectable internal clearance, sealed, lubrication nipple on circumference of outer ring
48	58	VSA 20	Four point contact bearing, standard series 20, external gear teeth, selectable internal clearance, sealed, lubrication nipple on circumference of ring without teeth
49	60	VSI 20	Four point contact bearing, standard series 20, internal gear teeth, selectable internal clearance, sealed, lubrication nipple on circumference of ring without teeth
49	62	VSU 20	Four point contact bearing, standard series 20, without gear teeth, selectable internal clearance, sealed, lubrication nipple on circumference of outer ring
48	64	VSA 25	As VSA 20 but with rolling element diameter 25 mm, internal clearance matched to series
49	66	VSI 25	As VSI 20 but with rolling element diameter 25 mm, internal clearance matched to series
49	68	VSU 25	As VSU 20 but with rolling element diameter 25 mm, internal clearance matched to series
78	88	XA	Crossed roller bearing, external gear teeth, preloaded, sealed, lubrication nipple on circumference of ring without teeth
79	88	XI	Crossed roller bearing, internal gear teeth, preloaded, sealed, lubrication nipple on circumference of ring without teeth
79	90	XU	Crossed roller bearing, without gear teeth, preloaded, sealed, lubrication nipple on circumference of ring without teeth
78	82	XSA 14	Crossed roller bearing, standard series 14, external teeth, sealed, preloaded, lubrication nipple on circumference of untoothed ring
79	84	XSI 14	Crossed roller bearing, standard series 14, internal teeth, sealed, preloaded, lubrication nipple on circumference of untoothed ring
79	86	XSU 14	Crossed roller bearing, standard series 14, without teeth, sealed, preloaded, lubrication nipple on circumference of outer ring

Index of suffixes

Sorting criteria:

A-Z; special symbols; 1,2,3,...

Suffix	Description
H	Hardened gear teeth on bearing ring
N	Normalised gear teeth on bearing ring
V	Quenched and tempered gear teeth on bearing ring
VSP	Bearing with preload
ZT	Centring on inner and outer rings
RR	Corrosion-resistant design with INA special plating Corrotect®
RL0, 1, 2, 3	Restricted internal clearance

Ordering designation

The ordering designation gives a short description of the bearing.

It consists of:

- the designation
- suffixes
 - for special bearing features only.

Designation (Figure 1)

The designation is given in the *dimension tables* and describes the standard design of the bearing.

The designation consists of several parts.

It indicates:

- the type
 - four point contact bearing (V), crossed roller bearing (X)
- the series
 - e.g. light series (L)
- the type of gear teeth
 - external teeth (A), internal teeth (I), without teeth (U)
- the dimension-specific part
 - rolling element diameter (D_W)
 - rolling element pitch circle diameter (D_M).

Suffix (Figure 2)

Suffixes are placed after the dimension-specific part.

They indicate:

- the heat treatment applied to the gear teeth
 - normalised (N), quenched and tempered (V), hardened (H)
- the special design
 - centring on the inner and outer ring (ZT)
 - restricted internal clearance for VL 20 (RLO, 1, 2, 3)
 - restricted internal clearance for VS 20 (RLO, 1, 2)
 - preload for VL 20 and VS 20 (VSP).

Note



For slewing rings in accordance with a drawing number (F- no.), the features *Centring*, *Rotational resistance* and *Internal clearance* cannot be ordered using suffixes.

For these bearings, the F- number must also be indicated when ordering.



Figure 1 · Designation – example of four point contact bearing

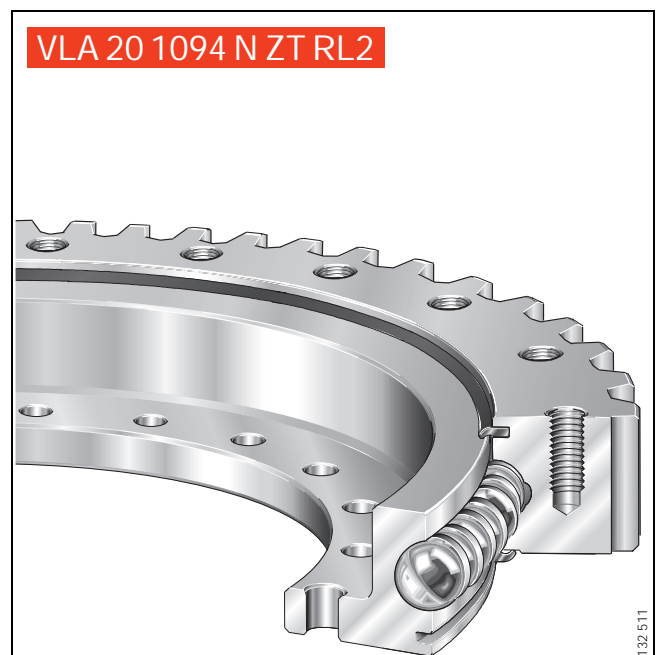



Figure 2 · Suffix – example of four point contact bearing

Ordering example, ordering designation

Four point contact bearing	V
Light series	L
External gear teeth	A
Rolling element diameter	20 mm
Rolling element pitch circle diameter	1 094 mm
Normalised gear teeth	N
With centring	ZT
Restricted internal clearance	RL2

Ordering designation:

VLA 20 1094 N ZT RL2 (Figure 3).

 The correct sequence of characters must be observed when ordering!

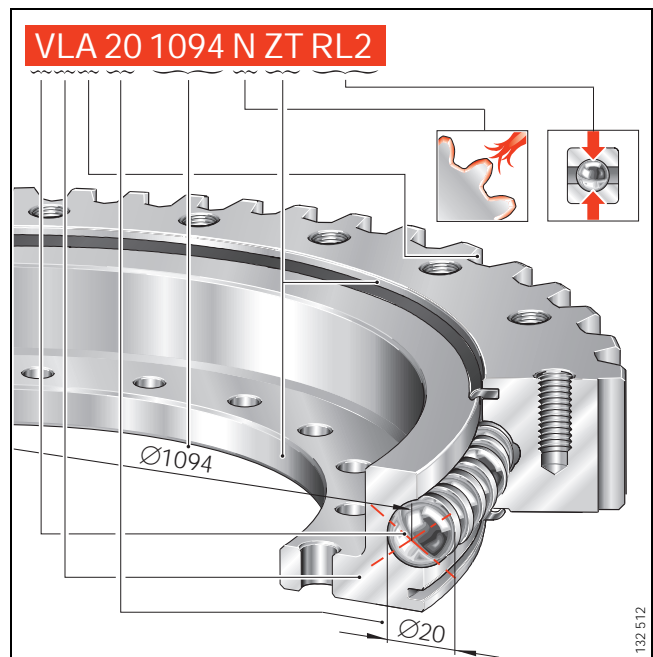

Figure 3 · Ordering example, ordering designation – four point contact bearing VLA 20

Symbols and units

Unless stated otherwise, the values used in the text have the following symbols, units of measurement and definition.

b	mm	Tooth width
C_a	kN	Basic axial dynamic load rating
C_r	kN	Basic radial dynamic load rating
C_{0a}	kN	Basic axial static load rating
C_{0r}	kN	Basic radial static load rating
d_M	mm	Mean bearing diameter
D_M	mm	Rolling element pitch circle diameter
D_W	mm	Rolling element diameter
f_A	–	Application factor
f_B	–	Type factor
f_L	–	Raceway factor
f_S	–	Factor for additional safety
F_a	kN	Dynamic axial bearing load
F_r	kN	Dynamic radial bearing load
$F_{z \max}$	kN	Maximum permissible tooth force (fracture strength)
$F_{z \text{ norm}}$	kN	Permissible tooth force (fatigue strength)
f_{0r}	–	Static radial load factor
F_{0a}	kN	Static axial bearing load
F_{0q}	kN	Equivalent static axial bearing load
F_{0r}	kN	Static radial bearing load
k	–	Load distribution factor
k_F	–	Dynamic load factor
L	10^6 rev.	Basic rating life in millions of revolutions
L_h	h	Basic rating life in operating hours
m	mm	Tooth modulus
m_{grease}	g	Grease quantity
M_K	kNm	Dynamic tilting moment load
M_W	kNm	Rotational resistance torque
M_{0k}	kNm	Static tilting moment load
M_{0q}	kNm	Equivalent static tilting moment load

n	min^{-1}	Operating speed of slewing ring
n_{osc}	min^{-1}	Frequency of to and fro movement
ρ	–	Life exponent
P	kN	Equivalent dynamic bearing load
P_{axial}	kN	Equivalent dynamic axial bearing load
P_{radial}	kN	Equivalent dynamic radial bearing load
Q_{spec}	kN/mm	Specific load
W_R	kN/m	Special frictional force due to seals, cages, etc.
x	–	Profile displacement factor
z	–	Number of teeth
α_A	–	Screw tightening factor
α_0	°	Transverse pressure angle of gear teeth
γ	°	Half of swivel angle
δ_B	mm	Maximum permissible flatness deviation
δ_W	mm	Maximum permissible perpendicularity deviation
$\delta_{S \text{ tilt}}$	mm	Maximum permissible increase in tilting clearance
ϵ	–	Load eccentricity parameter
μ	–	Frictional resistance factor

Load carrying capacity and life

Static load carrying capacity

The size of the slewing ring required is dependent on the demands made on its:

- static and dynamic load carrying capacity (*Dynamic load carrying capacity* see page 16)
- life (see *Dynamic load carrying capacity and life*, page 16)
- operational reliability.

Definition of static load carrying capacity

Slewing rings that undergo rotary motion only infrequently, undergo slow swivel motion, rotate only slowly or are subjected to load while stationary are dimensioned on the basis of their static load carrying capacity since the permissible load in these cases is determined not by material fatigue but by the load-induced deformations at the contact points between the rolling elements and raceways.

The static load carrying capacity is described by:

- the basic static load ratings C_0 (see *dimension tables*)
- the static limiting load diagrams *Raceway* and *Fixing screws* (see *dimension tables* and *calculation example*, page 15).

The size of a statically loaded slewing ring for a particular application can therefore be checked in approximate terms using the basic static load ratings C_0 and the static limiting load diagrams *Raceway*.

Checking the static load carrying capacity

The static load carrying capacity can be checked in approximate terms only when:

- the load arrangement is in accordance with Figure 3 (page 15)
- all the requirements stated in this publication are fulfilled in relation to
 - flange rings and location
 - fitting, lubrication and sealing.

 Where load arrangements are more complex or the conditions are not fulfilled, please consult Schaeffler.

In order to check the static load carrying capacity, the following equivalent static operating values must be determined:

- the equivalent static bearing load F_{0q}
 - the equivalent static tilting moment load M_{0q} .
- Checking is possible for applications with or without radial load.

Determining the equivalent static bearing load without radial load and checking the static load carrying capacity in the static limiting load diagram *Raceway*

If only axial and tilting moment loads are present, the following apply:

$$F_{0q} \triangleq F_{0a} \cdot f_A \cdot f_S$$

$$M_{0q} \triangleq M_{0k} \cdot f_A \cdot f_S$$

F_{0q} kN
Equivalent static axial bearing load

F_{0a} kN
Static axial bearing load

f_A -
Application factor (see Table 1, page 14)

f_S -
Factor for additional safety

M_{0q} kNm
Equivalent static tilting moment load

M_{0k} kNm
Static tilting moment load.

- Using the values for F_{0q} and M_{0q} , determine the load point in the static limiting load diagram *Raceway*.

 The load point must be below the raceway curve.
In addition to the raceway, check the dimensioning of the fixing screws as well (see *Calculation example*, page 15 and *Fixing screws*, page 20).



Determining the equivalent static bearing load with radial load and checking the static load carrying capacity in the static limiting load diagram *Raceway*.

! Radial loads can only be taken into consideration if the radial load F_{Or} is smaller than the basic static radial load rating C_0 according to the *dimension table*.

- Calculate the load eccentricity parameter ϵ using the formula.
- Determine the static radial load factor f_{Or} .
This should be done as follows:
 - determine the ratio F_{Or}/F_{0a} in Figure 1 or Figure 2
 - from the ratio F_{Or}/F_{0a} and ϵ , determine the static radial load factor f_{Or} from Figure 1 or Figure 2.
- Determine the application factor f_A according to Table 1, page 14 and the safety factor f_S if required.
- Calculate the equivalent axial bearing load F_{0q} and the equivalent tilting moment load M_{0q} using the formulae.
- Using the values for F_{0q} and M_{0q} , determine the load point in the static limiting load diagram *Raceway* (see *calculation example*, page 15).

! The load point must be below the raceway curve.

$$\epsilon = \frac{2000 \cdot M_{0k}}{F_{0a} \cdot D_M}$$

$$F_{0q} = F_{0a} \cdot f_A \cdot f_S \cdot f_{Or}$$

$$M_{0q} = M_{0k} \cdot f_A \cdot f_S \cdot f_{Or}$$

- ϵ - Load eccentricity parameter
- M_{0k} kNm - Static tilting moment load
- F_{0a} kN - Static axial bearing load
- D_M mm - Rolling element pitch circle diameter (*dimension tables*)
- F_{0q} kN - Equivalent static axial bearing load
- f_A - Application factor (see Table 1, page 14)
- f_S - Factor for additional safety
- f_{Or} - Static radial load factor (see Figure 1 or Figure 2)
- M_{0q} kNm - Equivalent static tilting moment load.

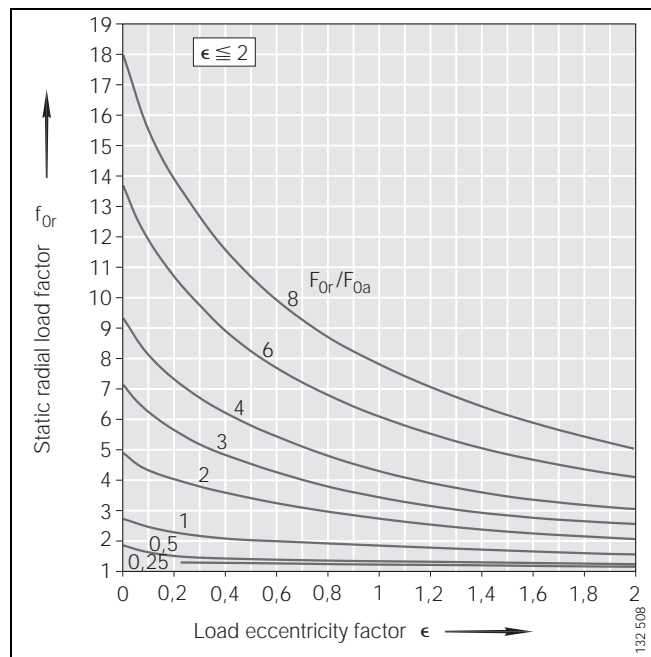

Figure 1 · Static radial load factor f_{Or} for four point contact bearings and crossed roller bearings

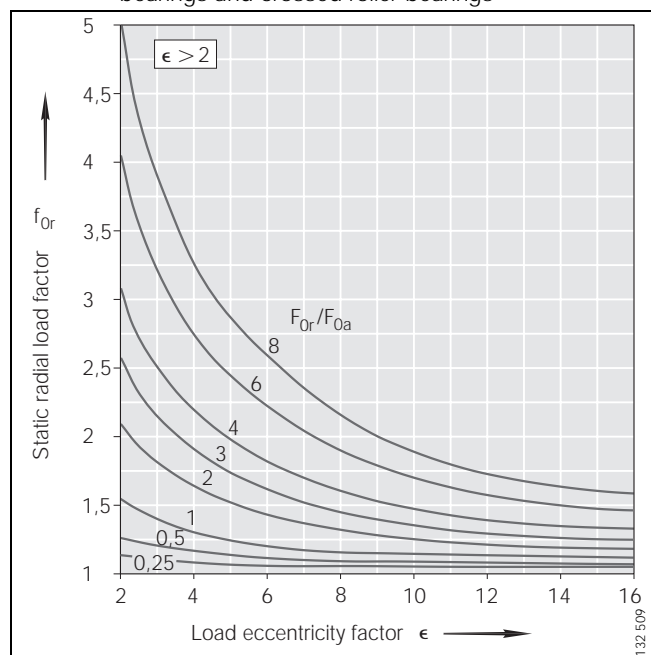

Figure 2 · Static radial load factor f_{Or} for four point contact bearings and crossed roller bearings

Application factors

The application factors f_A in Table 1 are empirical values. They take account of the most important requirements – e.g. the type and severity of operation, rigidity or running accuracy.

If the precise requirements of an application are known, the values may be altered accordingly.



Application factors < 1 must not be used.

A large proportion of applications can be statically calculated using an application factor of 1 – e.g. bearings for gearboxes and rotary tables.

Safety factors

The factor for additional safety is $f_S = 1$.

It is not normally necessary to factor in any additional safety in calculation.



In special cases, for example approval specifications, internal specifications, requirements stipulated by inspection bodies etc., the appropriate safety factor should be used.

Table 1 · Application factors for determining the equivalent static bearing load

Application	Operating/requirement criteria	Application factor f_A
Foundry operation	Severe conditions	1,5
Construction machinery (e.g. crane, dragline excavator, vibratory roller)	Severe conditions	1,25
Vehicles and vehicle attachments (e.g. lorry-mounted crane)	Severe conditions	1,25
Fork lift trucks and fork lift truck attachments	Light shocks	1,1
Sewage treatment plant	Vibrations	1,25
Wind power equipment	Risk of false brinelling	2
Robots	Rigidity	1,25
Antennae	Accuracy	1,5
Machine tools	Accuracy	1,5
Measuring equipment	Running noise	2
Medical equipment	Running noise	1,5



Calculation example

The four point contact bearing VSI 200744 N with internal gear teeth (see *dimension table*, page 60) for application in a crane is to be checked in relation to its static load carrying capacity.

Given

- Static axial bearing load $F_{0a} = 30 \text{ kN}$
- Static radial bearing load $F_{0r} = 15 \text{ kN}$
- Static tilting moment load $M_{0k} = 70 \text{ kNm}$
- Rolling element pitch circle diameter $D_M = 744 \text{ mm}$
- Application factor $f_A = 1,25$ (Table 1)
- Safety factor $f_S = 1$

Required

Static load carrying capacity of the bearing.

Solution

$$\epsilon = \frac{2000 \cdot M_{0k}}{F_{0a} \cdot D_M}$$

$$\epsilon = \frac{2000 \cdot 70}{30 \cdot 744} = 6,27$$

$$\frac{F_{0r}}{F_{0a}} = \frac{15}{30} = 0,5 \text{ (Figure 2)}$$

$$f_{0r} = 1,1 \text{ (Figure 2)}$$

$$F_{0q} = F_{0a} \cdot f_A \cdot f_S \cdot f_{0r}$$

$$F_{0q} = 30 \cdot 1,25 \cdot 1 \cdot 1,1 = 41,25 \text{ kN}$$

$$M_{0q} = M_{0k} \cdot f_A \cdot f_S \cdot f_{0r}$$

$$M_{0q} = 70 \cdot 1,25 \cdot 1 \cdot 1,1 = 96,25 \text{ kNm}$$

Determining the load point in the static limiting load diagram – checking the static load carrying capacity

Using the values for F_{0q} and M_{0q} , the load point in the static limiting load diagrams *Raceway* and *Fixing screws* is determined (see Figure 3 and Figure 4).

The load point is below the raceway and screw curves. The four point contact bearing VSI 200744 N is adequately dimensioned and therefore suitable for the application.

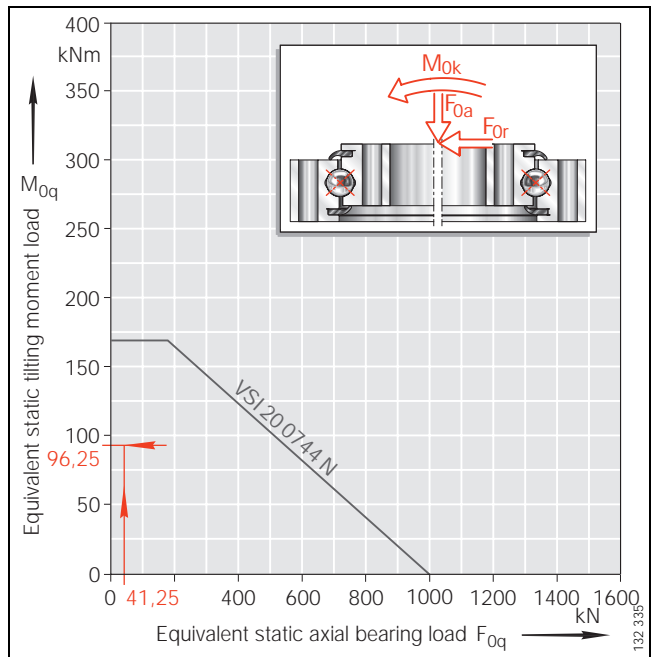

Figure 3 · Static limiting load diagram *Raceway* – supported load

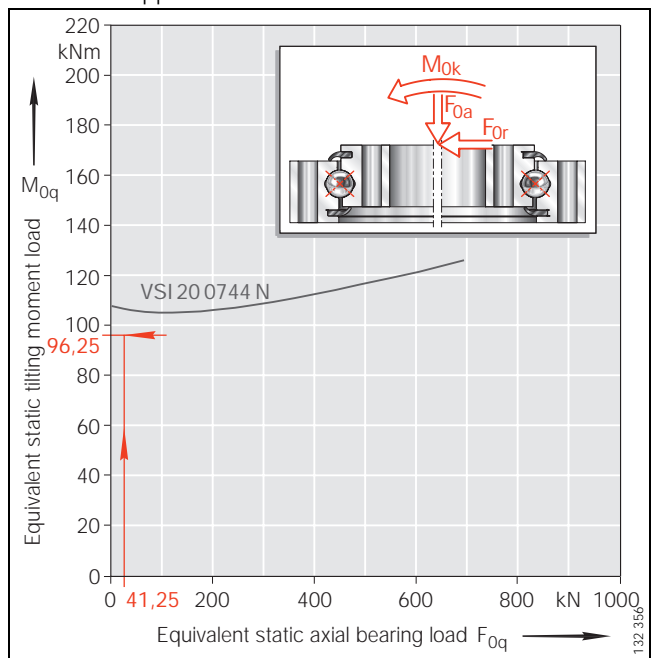

Figure 4 · Static limiting load diagram *Fixing screws* – supported load

Load carrying capacity and life

Dynamic load carrying capacity

Dynamically loaded slewing rings – i.e. bearings undergoing predominantly rotary motion – are dimensioned in accordance with their dynamic load carrying capacity.

Definition of dynamic load carrying capacity

The dynamic load carrying capacity is determined by the fatigue behaviour of the material. The life as a fatigue period depends on the load and operating speed of the bearing and the statistical probability of the first occurrence of failure.

The dynamic load carrying capacity is described by:

- the basic dynamic load ratings C (see *dimension tables*)
- the basic (calculated) rating life L or L_h .

The size of a dynamically loaded slewing ring for a particular application can therefore be checked in approximate terms using the basic dynamic load ratings and the basis rating life.

Definition of basic rating life

The basis for calculation is the theory of probability, according to which a defined percentage of a sufficiently large group of apparently identical bearings achieves or exceeds a particular number of revolutions before the first evidence of material fatigue appears. Calculation is based on a requisite reliability of 90%.

 The basic rating life is only an approximate value for guidance and comparative purposes.

Calculation of an adjusted rating life in accordance with ISO 281 is recommended if the nominal viscosity of the lubricant is not achieved for the specific operating load case (*Nominal viscosity* see page 33).

Determining the basic rating life

The life formulae for L and L_h are only valid:

- with a load arrangement in accordance with Figure 5
- if all the requirements stated in this catalogue are fulfilled in relation to
 - flange rings and location
 - fitting, lubrication and sealing
- if the load and speed can be regarded as constant during operation
 - if the load and speed are not constant, equivalent operating values can be determined that will cause the same fatigue conditions as the actual loads (see *Equivalent operating values, INA Catalogue 307*).
- if the load ratio is $F_r/F_a \leq 8$.

 If more complex load arrangements are present, a ratio $F_r/F_a > 8$ or if the conditions differ from those stated, please consult Schaeffler.

Determining the basic rating life for bearings subjected to combined loads

For bearings subjected to combined loads – bearings with axial, radial and tilting moment loads – the life L and L_h is calculated as follows:

- calculate the load eccentricity parameter ϵ using the formula
- determine the ratio of the dynamic radial bearing load F_r to the dynamic axial bearing load F_a (F_r/F_a)
- using the values for ϵ and the ratio F_r/F_a in Figure 5 or Figure 6, determine the dynamic load factor k_F
- calculate the equivalent dynamic axial bearing load P_{axial} using the formula
- enter the equivalent dynamic axial bearing load P_{axial} and the basic dynamic axial load rating C_a in the life formulae for L or L_h and calculate the life. If swivel operation is present, enter the operating speed n calculated using the formula in the life formula L_h .

Determining the basic rating life for bearings subjected to radial loads only

For slewing rings subjected to radial loads only, the following values are entered in the life formulae for L and L_h :

- instead of the equivalent dynamic axial bearing load P_{axial} , the equivalent dynamic radial bearing load P_{radial} (i.e. F_r)
 - $P_{radial} = F_r$
 - the basic dynamic radial load rating C_r .



$$\epsilon = \frac{2000 \cdot M_K}{F_a \cdot D_M}$$

$$P_{axial} = k_F \cdot F_a$$

$$L = \left(\frac{C}{P}\right)^p$$

$$L_h = \frac{16666}{n} \cdot \left(\frac{C}{P}\right)^p$$

$$n = n_{osc} \cdot \frac{\gamma}{90^\circ}$$

ϵ - Load eccentricity parameter

M_K kNm
Dynamic tilting moment load

F_a kN
Dynamic axial bearing load

D_M mm
Rolling element pitch circle diameter (*dimension table*)

P_{axial}, P_{radial} kN
Equivalent dynamic axial or radial bearing load.
This is used for P in the life formulae for L and L_h

k_F -
Dynamic load factor (see Figure 5 or Figure 6)

L 10^6 rev.
Basic rating life in millions of revolutions

C_a, C_r kN
Basic dynamic axial or radial load rating according to *dimension table*.

p -
Life exponent
for four point contact bearings: p = 3
for crossed roller bearings: p = 10/3

L_h h
Basic rating life in operating hours

n min^{-1}
Operating speed of slewing ring

n_{osc} min^{-1}
Frequency of to and fro movement

γ °
Half of swivel angle

F_r kN
Dynamic radial bearing load.

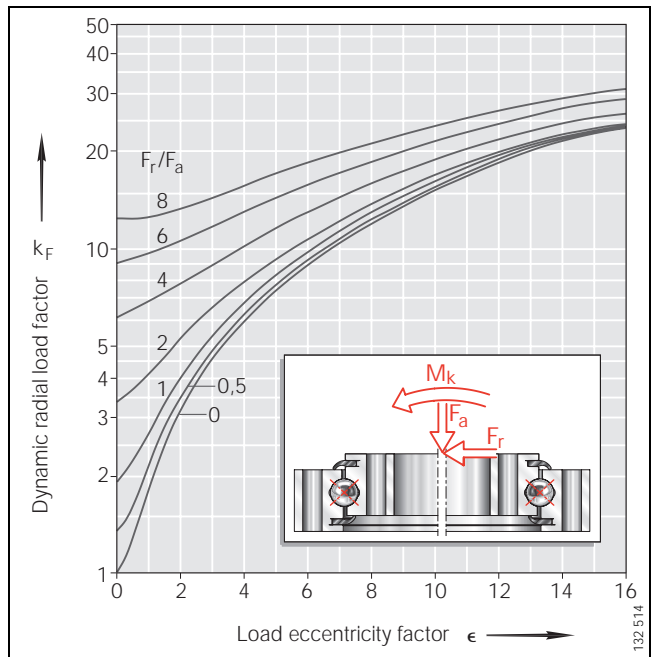

Figure 5 · Dynamic load factor k_F for four point contact bearings

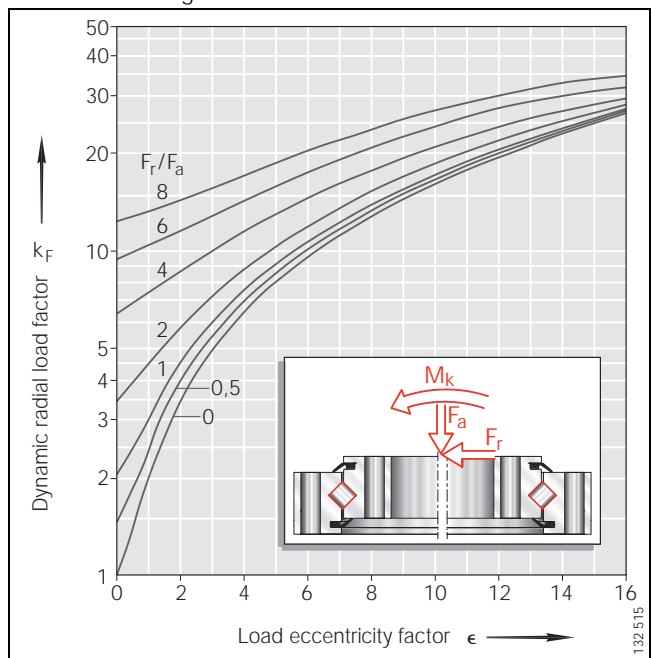

Figure 6 · Dynamic load factor k_F for crossed roller bearings

Influences on the operating life of slewing rings

The operating life is defined as the life actually achieved by a slewing ring. This can deviate significantly from the calculated basic rating life due to wear and/or fatigue.

Possible causes include:

- oscillating bearing motion with very small swivel angles – false brinelling
- vibration while the bearing is stationary
- unsuitable design or deformation of the adjacent construction
- excessively high operating temperatures
- incorrect maintenance or lubrication
- contamination
- incorrect fitting
- preload of the fixing screws.

Due to the variety of installation and operating conditions, it is not possible to precisely predetermine the operating life. The most reliable way of arriving at a close estimate is by comparison with similar applications.



Calculation example

For the crossed roller bearing XSU 14 0544 without gear teeth (see *dimension table*, page 86), the basic rating life L_h in operating hours is to be determined.

Given

Dynamic axial bearing load	$F_a = 80 \text{ kN}$
Dynamic radial bearing load	$F_r = 40 \text{ kN}$
Dynamic tilting moment load	$M_k = 32 \text{ kNm}$
Operating speed	$n = 2 \text{ min}^{-1}$
Life exponent for crossed roller bearings	$p = 10/3$
Basic dynamic axial load rating of slewing ring (according to <i>dimension table</i> , page 86)	$C_a = 270 \text{ kN}$
Rolling element pitch circle diameter	$D_M = 544 \text{ mm}$

Required

Basic rating life L_h .

Solution

$$\epsilon = \frac{2000 \cdot M_k}{F_a \cdot D_M}$$

$$\epsilon = \frac{2000 \cdot 32}{80 \cdot 544} = 1,47$$

$$\frac{F_r}{F_a} = \frac{40}{80} = 0,5$$

$$k_F = 3,3 \text{ (Figure 7)}$$

$$P_{\text{axial}} = k_F \cdot F_a$$

$$P_{\text{axial}} = 3,3 \cdot 80 \text{ kN} = 264 \text{ kN}$$

$$L_h = \frac{16\,666}{n} \cdot \left(\frac{C_a}{P_{\text{axial}}} \right)^p$$

$$L_h = \frac{16\,666}{2} \cdot \left(\frac{270}{264} \right)^{\frac{10}{3}} = 8\,980 \text{ h}$$

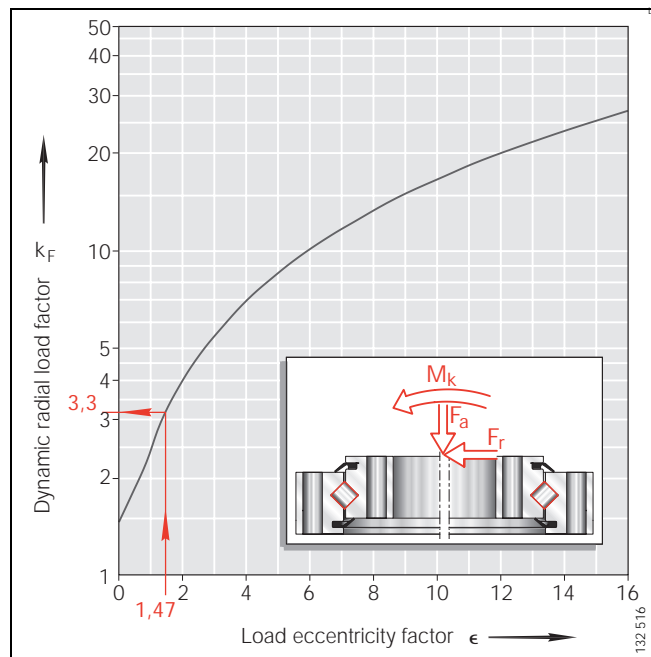

Figure 7 · Dynamic load factor k_F for crossed roller bearings

Fixing screws

Static and dynamic load carrying capacity

In addition to the raceway, the load carrying capacity of the fixing screws must also be checked. This is based on the information in the section *Static load carrying capacity* (page 12).

Conditions for checking load carrying capacity

The load carrying capacity of the fixing screws can be checked if the following conditions are fulfilled:

- the criteria in the section *Static load carrying capacity* are fulfilled
- the bearing load is supported; i.e. the bearing is installed such that the axial load relieves the screws
 - if the load is suspended, the screws are subjected to tensile forces by the axial load and must be of larger dimensions. In such applications, please consult Schaeffler
- the screws are tightened as specified using a torque wrench
 - screw tightening factor $\alpha_A = 1,6$,
tightening torques according to Table 3, page 46
- the permissible contact pressure (page 36 and page 42) is not exceeded.

If the actual conditions vary from those stated or if more complex load arrangements are present, please consult Schaeffler.

Indicator of load carrying capacity

The load carrying capacity of the screws is described by:

- the curves in the static limiting load diagrams *Fixing screws* (Figure 1 and *dimension tables*)
- the maximum permissible radial load $F_{r\text{ perm}}$ (friction locking) in the *dimension tables*.

Static limiting load diagrams

The screw curves are given in the static limiting load diagrams *Fixing screws* (see example in Figure 1) – the required safety factors have been included. The curves are based on screws of grade 10.9, tightened to 90% of their proof stress including the torsion content.

If screws of grade 8.8 or 12.9 are used, the equivalent static loads F_{0q} and M_{0q} (see *Static load carrying capacity*, page 12 and page 13) must be converted using the following factors:

- Grade 8.8
 - $F_{0q} \times 1,65$, $M_{0q} \times 1,65$
- Grade 12.9
 - $F_{0q} \times 0,8$, $M_{0q} \times 0,8$.

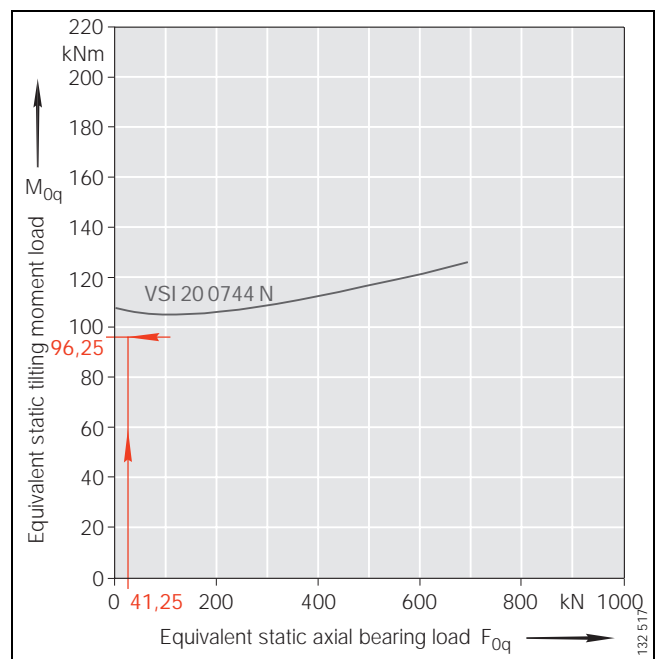

Figure 1 · Static limiting load diagram *Fixing screws* – example for four point contact bearing VSI 20 0744 N



Static load carrying capacity of fixing screws

The static load carrying capacity of the screw is limited by its proof stress.

Checking the static load carrying capacity without radial load

- From the equivalent static load F_{0q} and M_{0q} (see *Static load carrying capacity*, page 12 or page 13), determine the load point in the static limiting load diagram *Fixing screws* (see example in Figure 1).

⚠ The load point must be below the appropriate screw curve (see example in Figure 1).

Checking the static load carrying capacity with radial load

The screw connections must prevent displacement of the bearing rings in relation to the adjacent construction.

- ⚠ In addition to the initial checking, the following check must also be carried out with radial load:
- the maximum external radial load multiplied by the application factor f_A is compared with the maximum permissible radial load $F_{r\text{ perm}}$ in the *dimension tables* – the values are valid for screws of grade 10.9.

⚠ Factoring in the radial load gives guide values only. For high radial loads ($F_r/F_a > 4$), please consult Schaeffler.

Dynamic load carrying capacity of fixing screws

The dynamic load carrying capacity is the load that can be supported "permanently" by the screws. This corresponds to the fatigue strength of the screw.

Checking the dynamic load carrying capacity

- From the dynamic loads present, determine the equivalent loads F_{0q} and M_{0q} in accordance with the section *Load carrying capacity and life*, page 12 or page 13
 - instead of the application factor, the operating load must be increased by a factor according to Table 1
- Check the load carrying capacity in the static limiting load diagram *Fixing screws*
 - the load point must be below the appropriate screw curve (see example in Figure 1).

Table 1 · Factor for increasing the operating load

Screw grade	Increase factor
8.8	1,8
10.9	1,6
12.9	1,5

Rotational resistance

The rotational resistance of slewing rings is essentially determined by:

- the rolling resistance of the rolling elements
- the internal clearance or bearing preload
- the friction of the spacers or the cage or cage segments
- the seals.

The rotational resistance is also influenced by a large number of other parameters.

These include:

- the preload and lubrication of the seals
- the quantity of grease in the bearing
- the manufacturing tolerances
- the change in the internal clearance due to fitting
- the deformation of the adjacent construction.

Calculation of the rotational resistance

The rotational resistance torque M_W can only be calculated in approximate terms using the influences stated.

The factors required for calculation are given in Table 1.

$$M_W = \frac{D_M}{2000} \cdot \left(\mu \cdot k \cdot \left(\frac{M_K \cdot 1000}{D_M} + \frac{F_r \cdot f_L}{2} + \frac{F_a}{k} \right) + \frac{D_M \cdot W_R}{1000} \right)$$

M_W kNm
Rotational resistance torque

D_M mm
Rolling element pitch circle diameter (*dimension table*)

μ -
Frictional resistance factor (Table 1)

k -
Load distribution factor (Table 1)

M_K kNm
Dynamic tilting moment load

F_r kN
Dynamic radial bearing load

f_L -
Raceway factor (Table 1)

F_a kN
Dynamic axial bearing load

W_R kN/m
Specific frictional force due to seals, cages, etc. (Table 1).

Table 1 · Factors for determining the rotational resistance

Bearing type	μ	k	f_L	W_R
Four point contact bearing VL 20, VS 20 Standard clearance and preload	0,01	4,37	1,73 ¹⁾	0,21
Four point contact bearing VS 25, V	0,005	4,37	1,73 ¹⁾	0,21
Crossed roller bearing XS 14, X	0,004	4,08	1	$1 - \frac{(0,44 \cdot D_M)}{1000}$

1) The values are valid for a load consisting predominantly of tilting moment and axial force;

$f_L = 1$ for predominantly radial load if:
 $F_r \geq (450 \cdot M_K / D_M) + 0,1 \cdot F_a$.



The values determined using the formula may differ considerably from the actual values due to the influence of the aforementioned factors, e.g.:

- in the case of bearings subjected to low load or zero load
- due to the flatness and perpendicularity deviation of the adjacent construction
- for a ratio $\frac{M_K \cdot 2\,000}{D_M \cdot F_a} < 1$.

If the rotational resistance for the specific application is considerably less than the value calculated using the formula, please consult Schaeffler.

! If four point contact bearings of series VL 20 or VS 20 are used for spool bearing arrangements, large fluctuations in rotational resistance must be anticipated due to the nature of the application.

Dimensioning of rotary drives

For the dimensioning of rotary drives, account must be taken not only of the rotational resistance of the bearing but also:

- the acceleration power
- any tilted positioning of the machines
- any wind forces acting on the bearing arrangement.

If precise values are not available, the value of M_W used should be doubled.

Gear teeth

INA slewing rings are available in the following designs:

- with external gear teeth (A)
- with internal gear teeth (I)
- without gear teeth (U).

The letters A, I, U indicate the type of gear teeth – for the composition of the designation, see the section *Ordering example and ordering designation*, page 8.

Design and quality of gear teeth

As standard, the gear teeth on slewing rings are involute gear teeth without addendum modification ($\alpha_0 = 20^\circ$).

The gear teeth are of quality 12e28 or 12e29 and, in the case of the standard series XS 14, 10e27, in accordance with DIN 3 960, DIN 3 962-1 and DIN 3 967. Deviations are indicated in the *dimension tables*.

The runout of the gear teeth deviates from DIN 3 962 and is defined as the variation in wall thickness between the rolling element pitch circle diameter and the pitch circle diameter of the gear teeth (see *Accuracy*, page 50 and page 80).

The bottom clearance is $0,25 \times \text{modulus}$ and the minimum dedendum is $1,25 \times \text{modulus}$ (reference profile to DIN 867).

In order to prevent meshing interference, the tip on external gear teeth is reduced. This allows the use of pinions with a small number of teeth (at least 14 teeth).

Four point contact bearings VA and crossed roller bearings XA are designed in some cases without a tip reduction (see *dimension tables*).

Material and heat treatment

The heat treatment of the gear teeth is characterised by means of suffixes:

- normalised (N)
 - standard design of gear rings
- quenched and tempered (V)
 - special design of gear rings
- hardened (H)
 - special design of gear rings.

Example:

VLA 200414 N.

Four point contact bearing, light series 20, normalised gear teeth.

For the composition of the suffix, see the section *Ordering designation*, page 8.

Standard design of gear teeth

Slewing rings with gear rings made from normalised material C45N or 42CrMo4V65 (suffix N) have proved themselves in a wide range of applications.

The permissible tooth forces for each bearing are indicated in the *dimension tables*.

Special designs of gear teeth

If the permissible tooth forces indicated in the *dimension tables* are exceeded as a result of high circumferential forces, the gear teeth may be quenched and tempered. This increases the permissible tooth force by approximately 20%. The notch impact toughness in the low temperature range is also improved.

The gear ring material for the quenched and tempered design is 42CrMo4V, suffix V.

If there are particularly high requirements for the life of the gear teeth, the contour of the gear teeth can be hardened. The flanks and root of the teeth are hardened simultaneously.

These slewing rings are indicated by the suffix H.

The special designs "V" and "H" are only available by agreement for large quantities.

Further information on special designs is given in the *dimension tables*.

Tooth forces

The tooth forces F_z in the *dimension tables* have the following definitions:

- $F_{z \text{ norm}}$ = permissible tooth force (tooth base fatigue strength at a shock factor of 1,2).
- $F_{z \text{ max}}$ = maximum permissible tooth force (tooth base fracture strength at a shock factor of 1,35).

The values are applicable to:

- hardened and ground drive pinions
- tooth quality of the drive pinion 7b26
- driving pinion
 - with a driving wheel, the permissible value is 90% of the F_z value
- suspended pinion bearing arrangement
- swivelling operation
 - the maximum swivel speed is 1,5 m/s.

For other shock factors (see Table 1), the tooth forces indicated in the *dimension tables* can be converted on a linear basis.



A selection of the usual shock factors for gear teeth is given in Table 1 – for other operating conditions, please consult Schaeffler.

The shock factors are guide values for conversion of the tooth forces $F_{z\text{ norm}}$ and $F_{z\text{ max}}$.

Table 1 · Shock factors for gear teeth

Driven unit	Operation	Drive unit			
		Electric motor/ hydraulic motor Shock factor		Internal combustion engine Shock factor	
		norm.	max.	norm.	max.
Slewing gear Conveyor belts (continuous) Generators Sewage treatment plant Antenna bearing arrangements Medical equipment (X-ray equipment etc.) Measuring equipment	Uniform operation	1	1,1	1,1	1,25
Slewing gear in cranes Mixers Rolling mills Machine tool drives Vehicles Gearboxes Robots Wind power equipment Leisure equipment	Moderate shocks	1,2	1,35	1,3	1,5
Lifting gear Piston pumps Fork lift trucks Fork lift truck attachments Nail manufacturing machines	Medium shocks	1,35	1,6	1,5	1,75
Construction machinery Excavators Crushers Drilling equipment Cold rolling mills Opencast mining equipment Bark removal machines	Severe shocks	1,6	1,85	1,7	2

Drive pinion

If no particular transmission ratio is required, the following pinions in a hardened and ground design are suitable:

- pinions with 17 teeth without addendum modification
- pinions with 14 teeth and an addendum modification factor of $x = +0,5$.

A tip reduction of $0,1 \times \text{modulus}$ is recommended.

The gear tooth width of the pinion should project beyond the tooth width of the slewing ring on both sides by at least $0,5 \times \text{modulus}$.

In order to minimise the wear rate at low circumferential speeds ($v < 0,1 \text{ m/s}$), a quenched and tempered pinion of tooth quality 9b27 should be used. The permissible load carrying capacity of the gear pair is normally restricted by the load carrying capacity of the pinion.

The bearing arrangement of the drive pinion must be designed such that the pinion deflection under load is as small as possible.

Individual values for the gear pair can be calculated on request.

Tooth flank backlash

On toothed bearing rings, there is a green mark on the tooth tip at the point with the largest ring width (the largest distance between the rolling element pitch circle diameter D_M and the pitch circle diameter of the gear teeth). During fitting, the required tooth flank backlash ($0,03$ to $0,04 \times \text{modulus}$) must be set here – see *Fitting*, page 44.

Binding during operation can be prevented by the correctly adjusted tooth flank backlash.

The flank backlash can, for example, be eliminated by a drive pinion preloaded by a spring. It must be ensured, however, that sufficient bottom clearance is maintained.

Appropriate information is given in the technical literature.

Lubrication of the gear teeth

Suitable lubricants for the gear teeth are indicated in the section *Lubrication*, page 32, Table 3.

Lubrication

Correct lubrication and regular maintenance are important preconditions for achieving a long operating life with slewing rings.

The lubricant serves to:

- form a lubricant film capable of supporting loads on all contact surfaces
- seal the bearing against external influences (in the case of grease lubrication) and thus prevent the ingress of solid and liquid contaminants
- reduce the running noise
- protect the bearing against corrosion
- dissipate heat from rolling bearing subjected to heavy loads (in the case of oil lubrication).

Type of lubrication

Slewing rings can be lubricated with grease or oil.

The decisive factors in determining the appropriate type of lubrication and quantity of lubricant required are:

- the design and size of the bearing
- the design of the bearing environment
- the lubricant feed
- the operating conditions.

Lubrication of the gear teeth

The points stated above apply to the gear teeth of slewing rings.

The lubricant used should have good adhesion.

Suitable lubricants are given in Table 3, page 32.



Criteria for grease selection

Operating temperature range (Figure 1)

The range must correspond to the potential range of temperatures in the rolling bearing.

The possible operating temperatures should not exceed the upper and lower limit values:

- the maximum operating temperature should be +20 °C less than the upper limit value
- the minimum operating temperature should be +20 °C above the lower limit value. At very low temperatures, greases release very little base oil. This can result in inadequate lubrication.

Type of grease (Figure 2)

The characteristics of a grease depend on:

- the base oil
- the viscosity of the base oil
 - important for the speed range
- the thickener
 - the shear strength is important for the speed range
- the additives.

Consistency of greases (Figure 3)

Greases are divided into consistency classes – known as NLGI grades (DIN 51818). Grades 1, 2 and 3 are preferred for rolling bearings.

The greases should not become:

- too soft at high temperatures (NLGI 1)
- too stiff at low temperatures (NLGI 3).

- ⚠ Greases should be selected by their speed parameter $n \cdot d_M$:
 - greases with a low speed parameter should be used for bearings running at low speeds.

- ⚠ The consistency of polycarbamide greases can be altered by shear stresses.

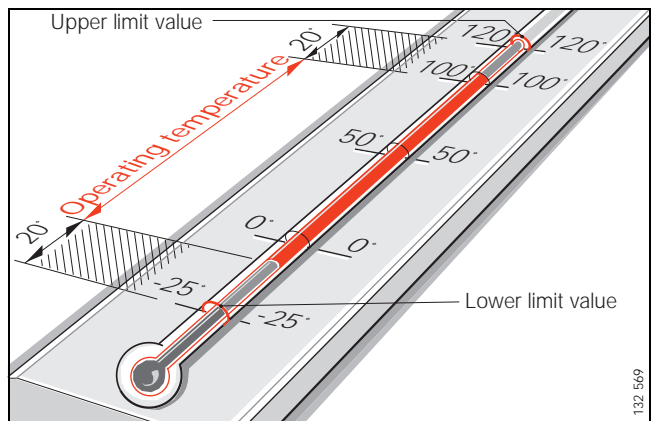

Figure 1 · Operating temperature range

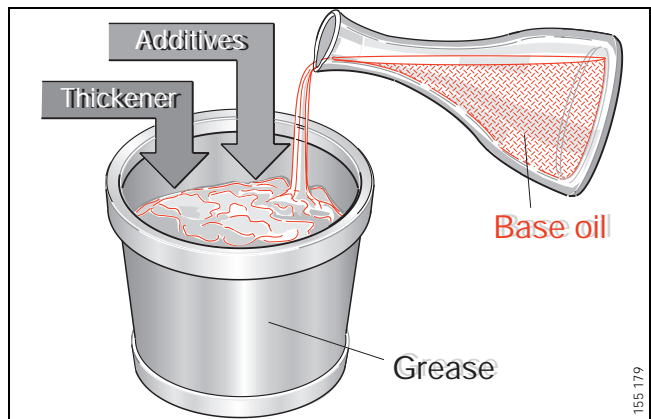

Figure 2 · Type of grease

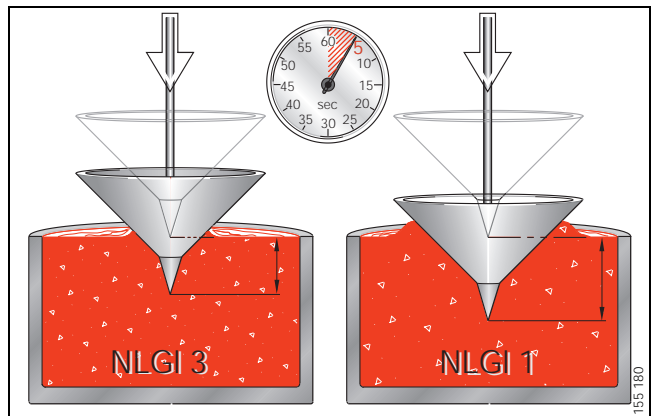

Figure 3 · Consistency of greases

Lubrication

Grease lubrication

Behaviour in the presence of water (Figure 4)

Water in the grease has a highly detrimental effect on the operating life of the bearing:

- the behaviour of greases in the presence of water is assessed according to DIN 51807 (see Table 1)
- the anti-corrosion characteristics can be checked in accordance with DIN 51802 – information is given in the grease manufacturer's data sheets.

Pressure properties

- The viscosity must be sufficiently high at the operating temperature for the formation of a lubricant film capable of supporting loads
- At high loads, greases with EP (extreme pressure) characteristics and high base oil viscosity should be used (KP grease to DIN 51502)
- Silicone greases should only be used with low loads ($P \approx 3\% C$).

- ⚠ The load-supporting capability of common greases can change if EP additives containing lead are not used.
Therefore:
- check the grease selection
 - consult the lubricant manufacturer.

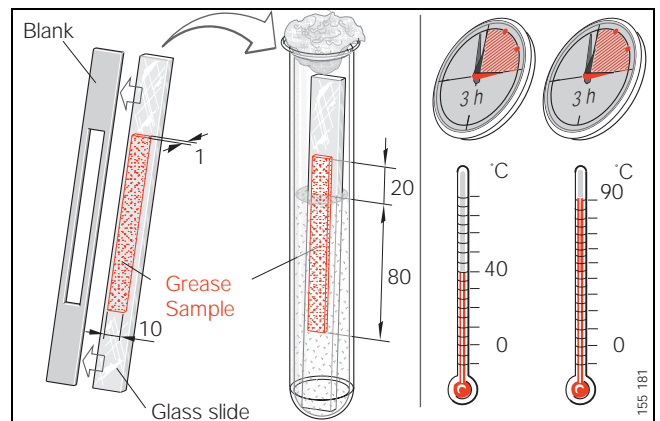

Figure 4 · Behaviour in the presence of water to DIN 51807

Table 1 · Bearing greases for initial greasing

INA designation	Designation to DIN 51825	Type of grease	Temperature range °C	NLGI grade (consistency)	Speed parameter $n \cdot d_M$ $\text{min}^{-1} \text{mm}$	Kinematic viscosity at 40 °C (base oil) $\text{mm}^2 \text{s}^{-1}$	Behaviour in the presence of water to DIN 51807
SM03	KP2N-20	Lithium complex soap grease (mineral oil base)	-25 ¹⁾ to +150	2	500 000	160	1-90

¹⁾ Determined according to IP 186/85.



Miscibility

The preconditions for miscibility are as follows:

- same base oil
- compatible thickener types
- similar base oil viscosities
 - the difference must not be more than one ISO VG class
- same consistency – NLGI grade.

⚠ If greases are to be mixed with each other, contact the grease manufacturer.

Storage (Figure 5)

⚠ Lubricants age due to environmental influences. The information provided by the lubricant manufacturer should be adhered to.

Schaeffler uses greases with a mineral oil base. Experience shows that these greases can be stored for up to 3 years.

The preconditions for storage are:

- closed room or store
- temperatures between 0 °C and +40 °C
- relative atmospheric humidity not more than 65%
- no contact with chemical agents (vapours, gases or fluids)
- rolling bearings sealed.

The start-up frictional torque of greased bearings may temporarily be higher than normal after extended periods of storage. The lubricity of the grease may also have deteriorated.

⚠ Greases – even those obtained from the same manufacturer – may vary in their characteristics. Therefore, Schaeffler does not accept any liability for lubricants and their behaviour during operation.

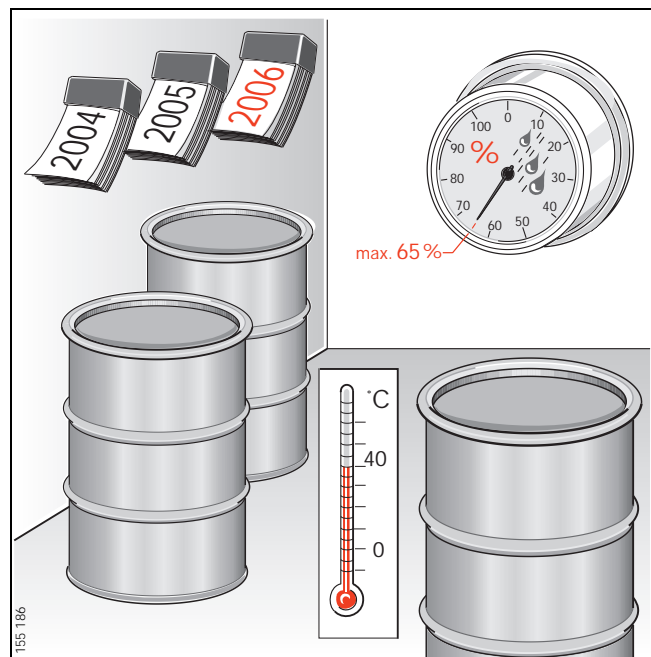

Figure 5 · Storage

Lubrication

Grease lubrication

Initial greasing

INA crossed roller bearings are supplied greased (for the grease used, see Table 1, page 28). The grease is a high quality lithium complex soap grease with a mineral oil base in accordance with DIN 51825-KP2N-20 and is suitable for temperatures from -25 °C to +150 °C

The total grease quantity can be calculated in approximate terms using the following formulae. Calculation gives a grease quantity that approximately fills the available free space in the raceway system of the bearing.

Grease quantity for four point contact bearings:

$$m_{\text{grease}} = \frac{D_M \cdot D_W^2 \cdot 0,7}{1000}$$

Grease quantity for crossed roller bearings:

$$m_{\text{grease}} = \frac{D_M \cdot D_W^2 \cdot 0,5}{1000}$$

m_{grease} g
Grease quantity

D_M mm
Rolling element pitch circle diameter (*dimension table*)

D_W mm
Rolling element diameter.

Lubrication intervals

The lubrication intervals are essentially dependent on:

- the operating conditions
- the environmental influences such as contamination, water, etc.
- the type of slewing ring.



The lubrication intervals can only be determined by means of tests under the specific application conditions:

- sufficiently long observation periods must be allowed
- the condition of the grease must be checked at regular intervals.

If comparable results are not available, guide values for the lubrication interval are given in Table 2.

The values are based on the following conditions:

- operating temperature < +70 °C
- circumferential speed < 0,5 m/s
- low to moderate load.

Table 2 · Guide values for the relubrication interval

Operating condition ¹⁾	Relubrication interval (guide value) ²⁾
Dry, clean rooms, e.g. rotary tables, robots	approx. 500 h
Severe contamination, operation outdoors e.g. crane, hydraulic excavator	approx. 50 to 200 h
Extreme contamination, e.g. drilling equipment in steelworks plant	Continuous relubrication by means of central lubrication systems or lubrication cartridges

¹⁾ For other operating conditions, please consult Schaeffler.

²⁾ For the gear teeth, the guide values should be taken as half the stated values.



Slewing rings – the raceway and gear teeth – must always be relubricated:

- after any cleaning, e.g. after spraying with water, steam etc.
- before and after extended periods of stoppage, e.g. for cranes and construction machinery during the winter months
- in conditions of high humidity.



Grease operating life

If relubrication is not possible, the grease operating life becomes the decisive factor.

Based on experience, the guide value for the grease operating life in the majority of applications is higher than the guide value for the relubrication interval by a factor of 2.



At operating temperatures above +70 °C, the lubrication interval and therefore the grease operating life are reduced.

In order to ensure operational reliability, the grease operating life should not exceed 3 years.

Relubrication procedure

Table 3, page 32, shows suitable lubricants for the raceway and gear teeth.

If slewing rings operate under high to very high load and at low to very low speeds, lubricants with base oils up to ISO VG 1 500 can be used in order to improve the lubricant film, depending on the operating temperature. In such applications, please consult Schaeffler.

The maintenance of bearings is described in detail in *INA Technical Product Information TPI 13*. This TPI is available upon request from Schaeffler.

Raceway

During the lubrication procedure, foreign matter such as contaminants, dust, spray water and condensation that have entered the slewing ring are pressed out.

If possible, the grease used for relubrication should be the same as that used in initial operation.

Lubrication should always be carried out on bearings that are warm from operation:

- clean the lubrication nipples.
- grease should then be pressed into the lubrication nipples until a collar of fresh grease forms around both seals (one bearing ring should slowly rotated during this process)
 - the old grease must be allowed to flow out unhindered.



Before initial operation, it must be ensured that all the lubricant ducts to the bearing are filled with lubricant.

Gear teeth

If possible, the grease used should be the same as that used in initial operation.

- The gear teeth, especially the tooth root surface, must be cleaned.
- The gear teeth must be sprayed or brushed with grease.

Lubrication

Grease lubrication

Lubrication using lubrication cartridges

Lubrication cartridges allow continuous relubrication of slewing rings up to 24 months. They are an independent greasing system and are thus also suitable for retrofitting.

The cartridges are filled with grease and located directly on the bearing or on the adjacent construction.

If the lubrication cartridges are applied to the adjacent construction, the grease is fed to the bearing via lubricant pipes.

Information on the use and handling of lubrication cartridges can be obtained from the relevant manufacturers.

Table 3 · Lubricants for the raceway and gear teeth

Raceway	Gear teeth	Temperature range ¹⁾	Manufacturer
Aralub HLP 2	Aralub LFZ 1	-30 °C to +130 °C	Aral
Energrease LS-EP 2	Energol WRL	-25 °C to +140 °C	BP
EPEXA	CARDREXA DC 1	-20 °C to +125 °C	ELF
BEACON EP 2	Surret Fluid 4 k	-25 °C to +140 °C	ESSO
Klüberlub BE 41-542	Grafloscon C-SG O Ultra (spray lubrication) Grafloscon A-G1 Ultra (hand lubrication) Grafloscon CA 901 Ultra-Spray (spray cans)	-25 °C to +140 °C	Klüber
-	Voler Compound 2000 E	-	Manke
Mobilgrease HP 222	Mobilnac D (spray lubrication) Mobilnac A (hand lubrication)	-20 °C to +120 °C	Mobil
Alvania EP (LF) 2	Cardium Compound C	-20 °C to +140 °C	Shell
Retinax LX 2 (INA designation: SM03)	Cardium Fluid C	-25 °C to +140 °C	

¹⁾ The temperature ranges stated are valid for the lubricants used on the raceway system.

Lubrication

Oil lubrication



For oil lubrication, Schaeffler recommends oils of type CL/CLP to DIN 51 517 or HL/HLP to DIN 51 524 (ISO VG 10 to 100).

The oils can be used at operating temperatures from $-30\text{ }^{\circ}\text{C}$ to $+100\text{ }^{\circ}\text{C}$.

! Note the limiting speeds for n_G grease and n_G oil according to the *dimension tables*.

Selection of the oil

A lubricant film capable of supporting loads is required at the contact points between the rolling elements and the raceway. Depending on the operating speed, at the operating temperature the oil must have:

- at least the nominal viscosity ν_1 (Figure 6).

Nominal viscosity for mineral oils

The guide value for ν_1 is dependent on:

- the mean bearing diameter d_M
- the speed n .

It takes account of the EHD theory of lubricant film formation and practical experience.

Determining the nominal viscosity ν_1 according to the example (Figure 6):

- assign ν_1 to an ISO VG nominal viscosity grade between 10 and 1500
 - mean viscosity to DIN 51 519
- intermediate values should be rounded to the nearest ISO VG grade
 - this is due to the steps between the viscosity groups.

! This method cannot be used for synthetic oils
 - these have different speed/pressure and speed/temperature characteristics.

Influence of temperature on viscosity

As the temperature increases, the viscosity of the oil decreases.

! When selecting the viscosity, the lowest operating temperature should be taken into consideration:
 - increasing viscosity reduces the flowability of the oil and leads to increased power losses.

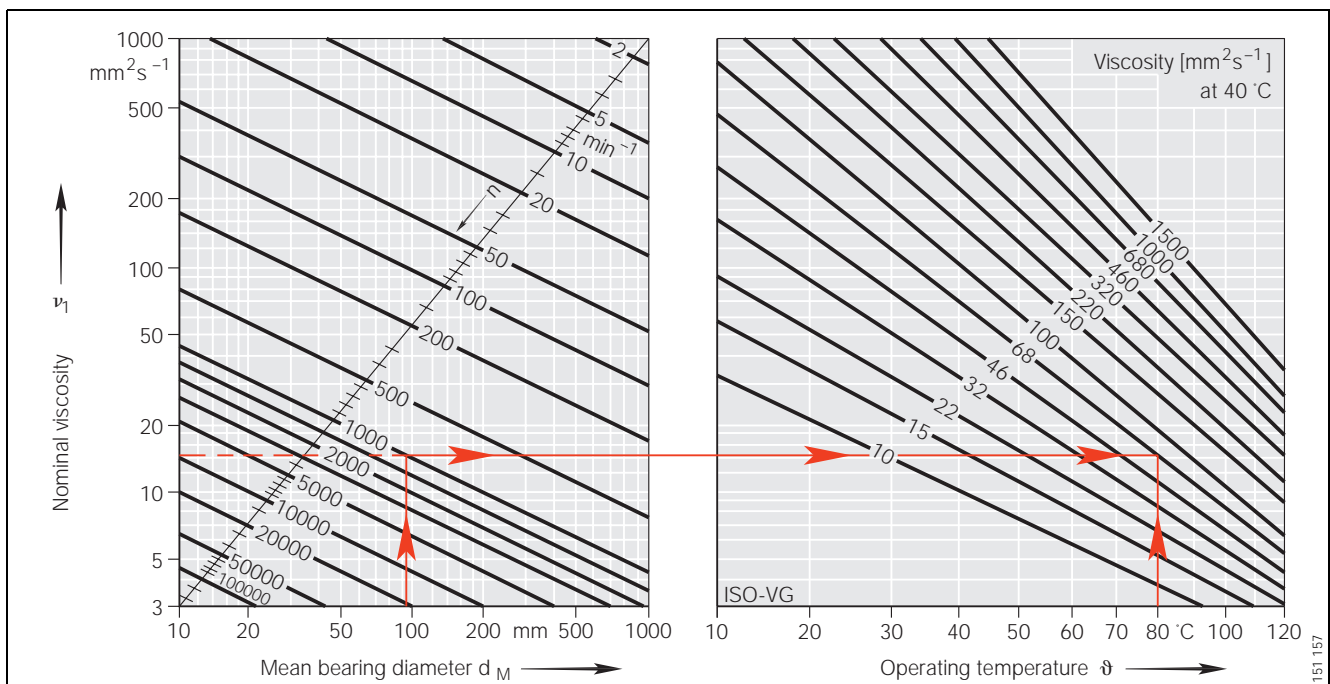

Figure 6 · Determining the nominal viscosity ν_1

Sealing of the bearing arrangement

INA seal profiles

INA slewing rings are supplied sealed.

Depending on the requirement and type of contamination – e.g. heavy contamination, high humidity, spray or flood water etc. – additional sealing of the bearing position in the adjacent construction may be necessary.

INA seal profiles

For sealing of the bearing arrangement in the adjacent construction, Schaeffler supplies various seal profiles by the metre. These profiles fulfil a wide variety of requirements (see Table 1). Installation drawings can be requested for the individual seal profiles.

 The seal profiles are not suitable for applications requiring leakproof operation – or for grease lubrication. If leakage losses are unacceptable, measures such as rotary shaft seals can be applied.

Seal profile materials

The standard material for the profiles is the synthetic elastomer NBR 70. This material is characterised by:

- good resistance to oils and greases
- good wear resistance.

Operating temperature

INA seal profiles can be used at temperatures from $-40\text{ }^{\circ}\text{C}$ to $+80\text{ }^{\circ}\text{C}$.

For temperatures lower or higher than this range, extreme environmental influences (e.g. ozone) or high speeds, please consult Schaeffler.

Fitting of seal profiles

 The area around the bearing seal must be designed such that the seal profiles are not damaged during operation. Ensure that the profiles are not damaged while fitting the slewing ring.

Fit the profiles according to the following procedure:

- clean the area where the seal is to be fitted.
- press the seal profile carefully into the fitting space leaving an excess length of approximately 5% – e.g. with a blunt wooden wedge (Figure 2).
- cut the profile to the exact length (Figure 2) – ensure that the joint faces are even.
- join the grease-free joint faces using a cyanacrylate adhesive without displacement (Figure 3) – e.g. using Loctite 406.
- complete the fitting of the profile (Figure 3).

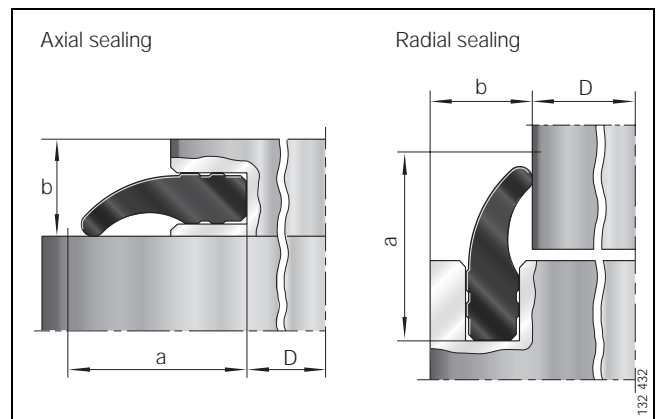

Figure 1 · Dimensioning of the fitting space and the diameter

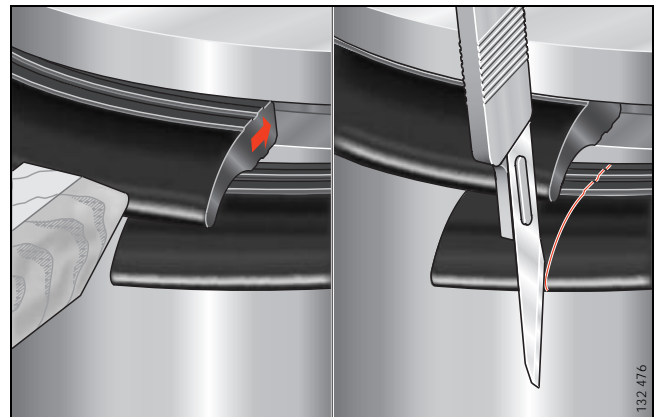

Figure 2 · Pressing in and cutting of the profile in the fitting space

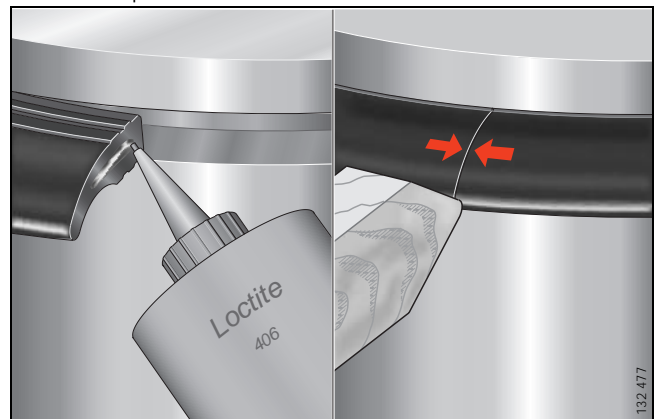

Figure 3 · Bonding of the joint faces and final fitting of the profile



Table 1 · Seal profiles – selection scheme and characteristics

Profile Cross-section		Designation	Diameter range ¹⁾ D		Fitting space required (guide values) ¹⁾		Characteristics
axial sealing	radial sealing		axial	radial	a	b	
 132.433	 132.434	A/R 0101 A/R 0106 A/R 0207 A/R 0509	100 to 500 100 to 500 300 to 1000 >400	100 to 500 200 to 700 300 to 1000 >400	8 9,5 11 17	5 5 7,5 10	<ul style="list-style-type: none"> – for normal sealing requirements – also suitable for severe contamination
 132.435	 132.436	A/R 0218 A/R 0419	300 to 1000 >400	300 to 1000 >400	12 16	7,5 10	<ul style="list-style-type: none"> – low frictional torque
 132.437	 132.438	A/R 1025 A/R 1126 A/R 1227	>200 >400 >400	200 to 1000 400 to 1000 >400	8 12 16	5,5 9 11	<ul style="list-style-type: none"> – little design space required – protected by fitting in the bearing gap
radial sealing							
 132.549	 132.439	R 2001 ① R 2009 ②	–	>300	13	9,5	<ul style="list-style-type: none"> – higher contact pressure due to tension spring – particularly suitable for sealing against fluids – only for low speeds or swivel operation
axial and radial sealing							
 132.440	 132.441	AR 0501	>400	>400	19	14,5	<ul style="list-style-type: none"> – long maintenance intervals – double direction (axial and radial)

¹⁾ Dimensioning of the fitting space and the diameter: see Figure 1.

Design of bearing arrangements

INA slewing rings can, as a single bearing position (Figure 1), transmit:

- axial loads from both directions
- radial loads
- tilting moment loads.

In order that these advantages can be utilised comprehensively, the adjacent construction must be of an appropriate design.

- ⚠ Bearing rings must always be rigidly and uniformly supported around their entire circumference and width. The adjacent construction must be designed only in accordance with the information in this section. Any deviations from the specifications, material strength and adjacent components will considerably reduce the load carrying capacity and operating life of the slewing rings.

Sealing of the bearing position

If the bearing arrangement is sealed by means of a seal in the adjacent construction, observe the design guidelines for seal profiles in the section *Sealing*, page 34.

- ⚠ The area around the bearing seal must be designed such that the seal profiles are not damaged during operation.

Fixing screws

Screws of grade 10.9 are suitable for fixing the bearing rings or clamping rings (see *Fitting*, page 46, Table 3) – the dimensioning and tightening torque are dependent on the bearing size.

- ⚠ Any deviations from the recommended size, grade and number of screws will considerably reduce the load carrying capacity and operating life of the bearings.

Permissible contact pressure

The permissible contact pressure under the screw heads and nuts for the adjacent construction is:

- for St37 = 260 N/mm²
- for St52 = 420 N/mm².

If these values are exceeded, quenched and tempered washers must be used under the screw heads and nuts – see also page 42.

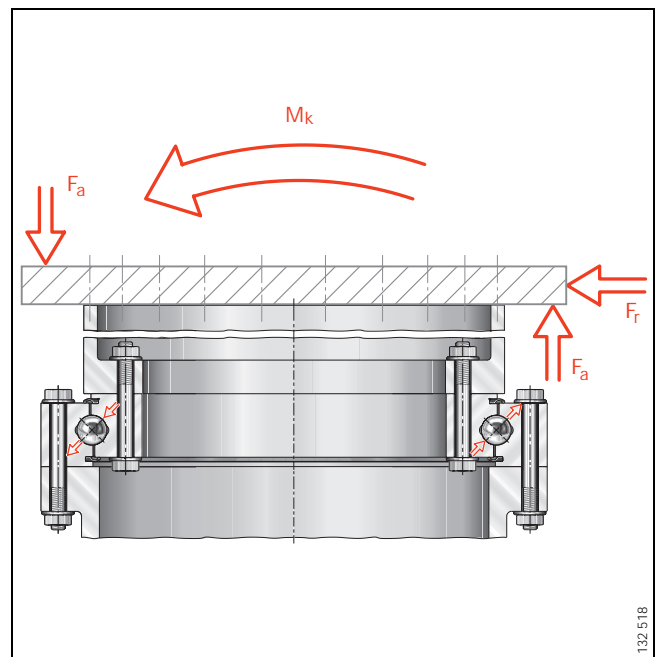

Figure 1 · Load transmission – axial, radial, tilting moment load



Location by cylindrical pot

Slewing rings are screw mounted directly to the adjacent construction through both bearing rings (Figure 2).

The adjacent construction must be flat and uniformly rigid, while the connection between the bearing adjacent components must be by force locking. For the upper and lower adjacent construction, a cylindrical pot with a flange ring has proved effective (Figure 2).

The wall thickness t of the pot should be approximately one third of the flange thickness s and the pot height H_T should be at least five times the flange thickness s (Figure 2). For a more uniform rigidity of the bearing arrangement, thicker walls of the pot and flange ring are more favourable than thin walls with ribs. In order to achieve the most linear force flow possible, arrange the pot precisely above or below the row of rolling elements.

Dimensioning of the flange thickness

 Flange rings should be dimensioned such that they support the whole width of the bearing rings (Figure 2).

The recommended flange thickness s can be determined (Figure 3) using the specific load Q_{spec} (formula) and the ratio D_M/D_W (Figure 3).

$$Q_{spec} = \frac{C_{0a}}{D_M \cdot \pi \cdot f_B}$$

Q_{spec} kN/mm
Specific load

C_{0a} kN
Basic axial static load rating (*dimension table*)

D_M mm
Rolling element pitch circle diameter

D_W mm
Rolling element diameter

f_B -
Type factor
Four point contact bearings: $f_B = 0,8$
Series VL 20: $f_B = 0,5$
Series VS 20: $f_B = 0,75$
Crossed roller bearings: $f_B = 0,7$.

The values are applicable to:

- an adjacent construction in accordance with Figure 2
- an adjacent construction with the material strength of St 37 or better
- bearings where the static load carrying capacity is used to the full. If loads are considerably lower, the flange thickness s can be reduced to approximately 80% of the recommended value. In such cases, please consult Schaeffler.

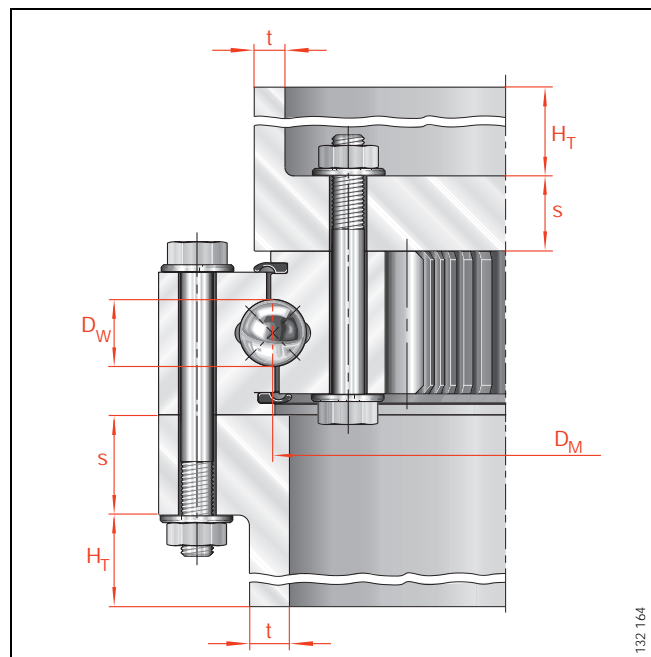

Figure 2 · Four point contact bearing between upper and lower adjacent construction

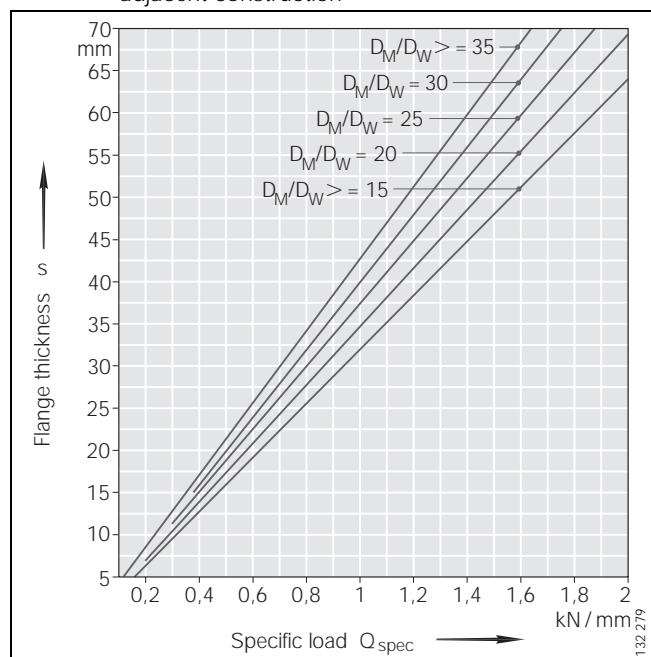

Figure 3 · Recommended flange thicknesses for four point contact and crossed roller bearings

Permissible flatness and perpendicularity deviation of the adjacent construction

The screw mounting surfaces of the adjacent construction must fulfil the following requirements:

- the flatness deviation must not exceed the permissible value δ_B (Figure 4)
- the perpendicularity deviation must not exceed the permissible value δ_W (Figure 5).

Permissible flatness deviation

The flatness deviation δ_B applies in the circumferential ① and transverse direction ② (Figure 4):

- in the circumferential direction, it can only be reached once in a sector of 180°. The permissible curve is similar to a slowly rising or slowly falling sine curve.

The permissible flatness deviation for four point contact bearings of a standard design (i.e. with internal clearance) is determined using this formula:

$$\delta_B = \frac{D_M + 500}{10\,000}$$

The following formula is valid for:

- through hardened bearings
- preloaded four point contact bearings
- crossed roller bearings.

$$\delta_B = \frac{D_M + 1\,000}{20\,000}$$

δ_B mm
Maximum permissible flatness deviation

D_M mm
Rolling element pitch circle diameter.

Permissible perpendicularity deviation

The perpendicularity deviation δ_W applies in the transverse direction ① (Figure 5):

- relative to a flange width of 100 mm, the perpendicularity deviation δ_W must not exceed half the permissible flatness deviation δ_B ($\delta_W \leq 0,5 \delta_B$). For other flange widths, the permissible deviation can be converted proportionally.

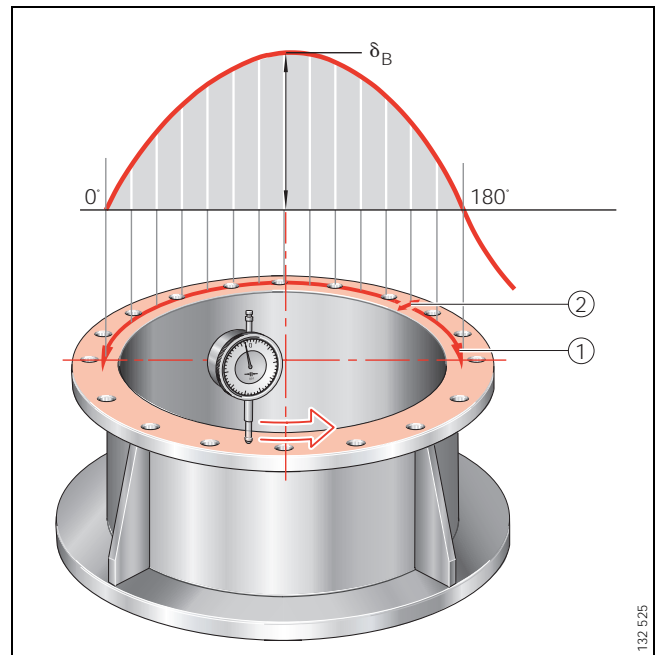

Figure 4 · Permissible flatness deviation

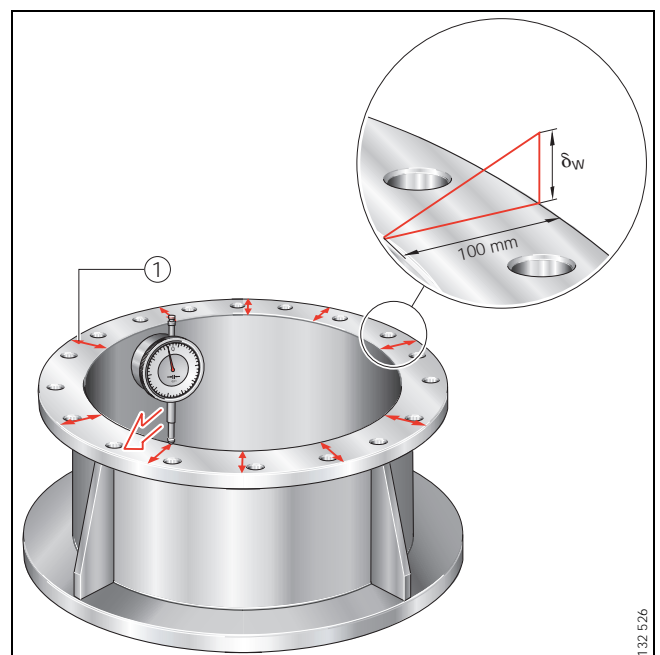

Figure 5 · Permissible perpendicularity deviation



Slewing rings must be handled with care before and during assembly. Their function and operating life are also dependent on the care taken in fitting.

Design of the assembly area

! Machines, equipment, etc. that produce swarf or generate dust must not be used in the immediate vicinity of the assembly area.

The bearings must be protected against dust, contamination, swarf, moisture, adhesives, etc. Contamination will impair the function and operating life of the bearings.

Bearings should be fitted in a workshop if possible. If this is not possible, the fitting position and bearing should be protected against contaminant from the environment.

It must be ensured that work surfaces are bright, clean and free from fibres (e.g. plastic) and that lighting conditions are good.

Preparing the adjacent construction for fitting of the bearings

The bores and edges of the adjacent components must be free from burrs:

- any burrs present must be removed using an oilstone (Figure 1).

The support surfaces for the bearing rings must be clean.

Cleaning (Figure 1):

- apply cleaning agents using a brush or a suitable, lint-free cloth.
- remove any foreign matter and dry the surfaces.

! Ensure that all adjacent components and lubrication ducts are free from cleaning agents, solvents and washing emulsions. The bearing seating surfaces can rust or the raceway system can become contaminated.

Checking the seating and screw mounting surfaces for the bearing on the adjacent construction

- Check the surface quality and the geometrical accuracy of the screw mounting surfaces in accordance with the section *Design of bearing arrangements* or the assembly drawing.
- Check the flange thickness s , the pot height H_T and the pot wall thickness t in accordance with the section *Design of bearing arrangements* or the assembly drawing (Figure 2).
- Check the flatness and perpendicularity deviation of the adjacent construction in accordance with the section *Design of bearing arrangements* or the assembly drawing (page 38).

! Do not exceed the permissible deviations.

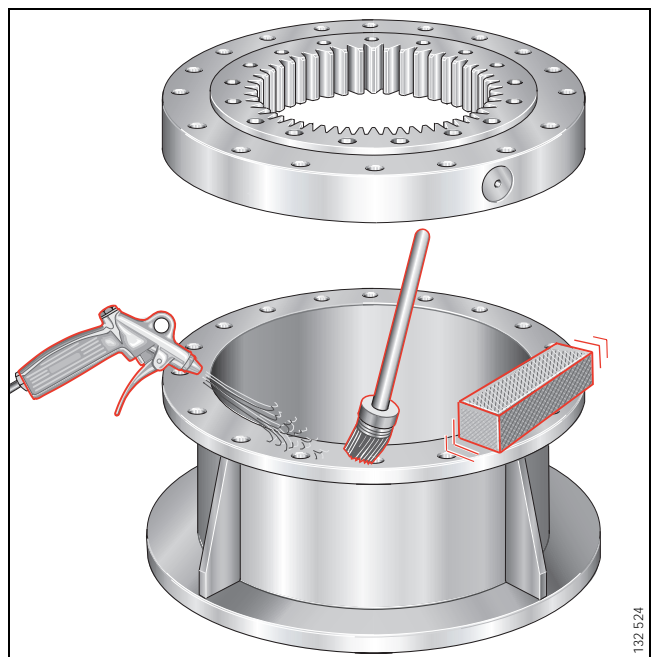

Figure 1 · Preparing the adjacent construction

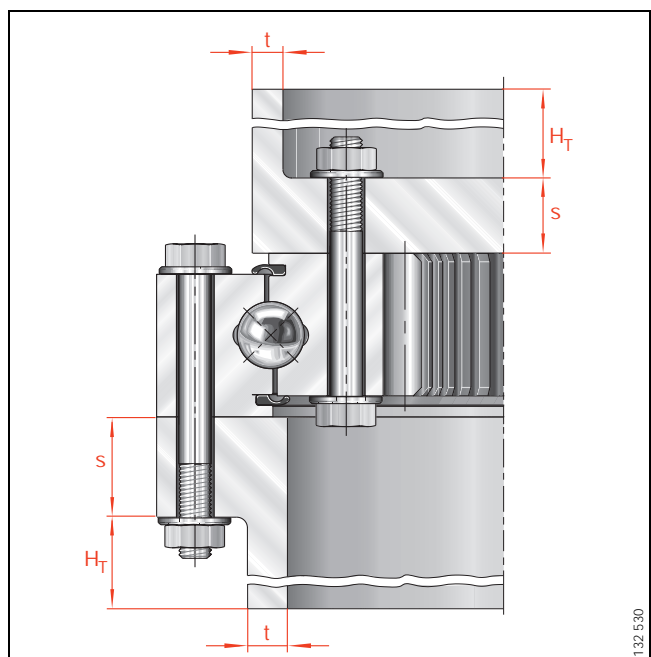



Figure 2 · Flange thickness s , pot height H_T and pot wall thickness t

Storage and storage life of slewing rings

 Bearings should only be stored lying down, never standing up (Figure 3).

The storage life of the bearings is limited by the storage life of the grease. Experience shows that the greases with a mineral oil base used can be stored for up to 3 years if the following preconditions are met:

- closed storage room
- dry, clean rooms with temperatures between 0 °C and +40 °C
- relative atmospheric humidity not more than 65%
- no influence by chemical agents such as
 - vapours, gases, fluids.

After long storage periods, the frictional torque may temporarily be higher than that of freshly greased bearings. The lubricity of the grease may also have deteriorated.

Delivered condition of slewing rings

INA slewing rings are:

- greased with a lithium complex soap grease KP2N-20 to DIN 51825
- dry preserved using VCI paper.



Unpacking and transporting slewing rings

Perspiration from handling leads to corrosion. Hands must be kept clean and dry; protective gloves should be worn if necessary.

Bearings should not be removed from their original packaging until immediately before assembly. If the original packaging is damaged, check the condition of the bearing.

Large bearings should only be transported lying down if possible.

Heavy bearings must only be transported using a hoist attached to the eye bolts or by means of textile slings (Figure 4).

-  Bearings must not be wrapped in a chain.
-  Bearings should never be supported at one point only for lifting.

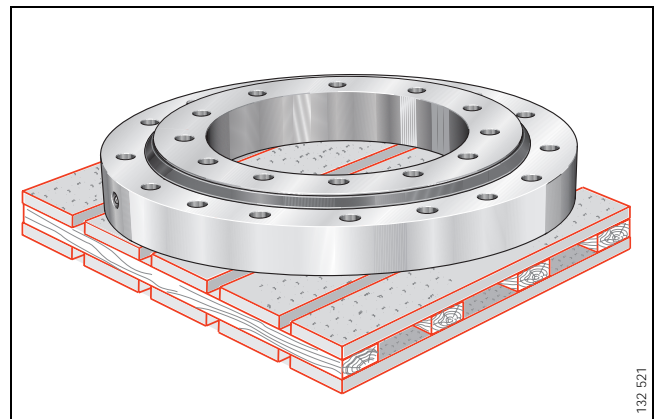

Figure 3 · Storage of slewing rings

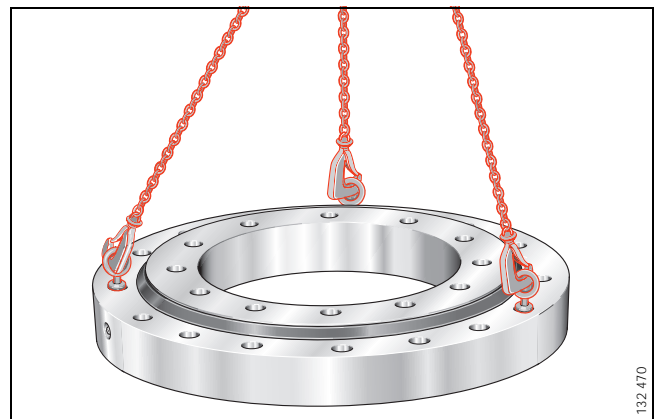

Figure 4 · Transport of bearings



Cleaning of slewing rings

Any anti-corrosion coatings must be removed from the support and contact surfaces of the bearing rings before the slewing ring is fitted. Suitable cleaning agents include:

- petroleum, diesel oil, commercially available grease solvents (e.g. acetone, isopropanol).



The appropriate legal regulations relating to the use of cleaning agents (manufacturer's instructions and regulations covering health and safety at work, environmental protection, etc.) must be observed.

Cleaning agents must be disposed of correctly after use.

Cleaning:



Cleaning agents must not be allowed to penetrate the raceway system of the slewing ring.

In slewing rings with gear teeth, the narrowest point of the tooth set is marked in green at the tooth tip ① (Figure 5). This marking must not be removed since the tooth flank backlash ② is set at this point.

- apply cleaning agents using a brush or a suitable, lint-free cloth.
- remove any foreign matter and dry the surfaces.

Hardness gap on slewing rings

For the fitting of slewing rings, not only the marking on the tooth tip but also the so-called hardness gap is important.

The hardness gap is the point between the start and end of the raceway hardening. This point is indicated by (Figure 6):

- the indented INA logo ①
- the closing plug ②.

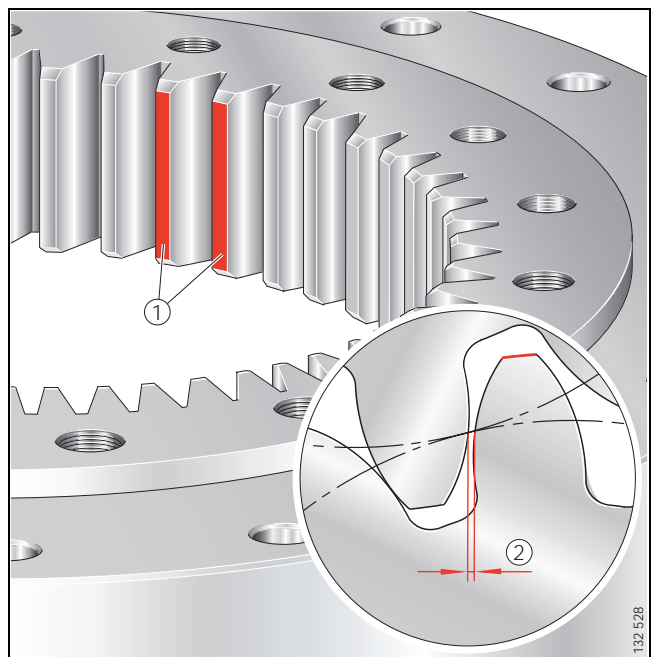

Figure 5 · Narrowest point of tooth set

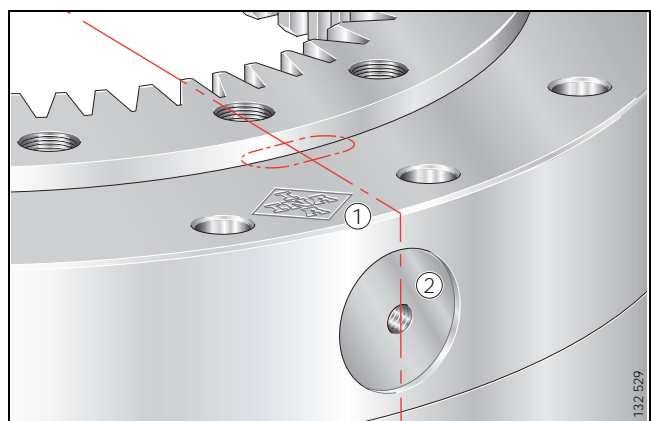

Figure 6 · Hardness gap

Fitting

Preparations for fitting

Provision of fasteners



The specifications relating to the fasteners must be observed.

Any deviations will influence:

- the effectiveness of the screw connection
- the function – e.g. the accuracy and rigidity – as well as the operating life of the bearings.

Fixing screws

Bearings must only be fixed using the screw types specified. It is essential that the information in the following sources is followed:

- this catalogue
- the technical proposal
- the customer's assembly drawing.

The sizes, quantity and grades of the screws are given in the *dimension tables* or in the assembly drawing.

Permissible contact pressure

The permissible contact pressure under the screw heads and nuts given in Table 1 must not be exceeded. If the contact pressure is higher, quenched and tempered washers must be used under the nuts.

If screws of grade 12.9 are used, it is essential that quenched and tempered washers are always used.

Table 1 · Permissible contact pressure for bearing rings and adjacent construction

Permissible contact pressure for bearing rings made from	Contact pressure N/mm ²	Permissible contact pressure for adjacent construction made from	Contact pressure N/mm ²
normalised steel C45N or 42CrMo4V65	500	St37	260
quenched and tempered steel 42CrMo4V	850	St52	420

Securing of screws

Normally, the screws are adequately secured by the correct preload. If regular shock loads or vibrations occur, however, it may be necessary to provide additional means of securing the screws.



Not every method of securing screws is suitable for slewing rings.

Never use spring washers or split washers.

General information on the securing of screws is given in DIN 25 201, and securing by means of adhesive in particular is described in DIN 25 203, issued in 1992.

If these are to be used, please consult the relevant manufacturers.

General safety and operating guidelines



Assembly forces must only be applied to the bearing ring to be fitted; they must never be directed through the rolling elements or seals. Avoid direct blows on the bearing rings.

Bearing rings should be located consecutively and without external load.

Bearings must not be heated using a naked flame. In this case, the material undergoes excessive localised heating, which will reduce its hardness. Furthermore, stresses will be induced in the bearing.

Do not cool the bearings excessively. The formation of condensation can lead to corrosion in the bearings and on the bearing seating surfaces.

Sequence of operations

The sequence depends on the design of the adjacent construction. The description of fitting is based on applications that have proved successful in practice.

If the adjacent construction is different, fit the bearing appropriately or consult Schaeffler.

Fitting

Fitting of slewing rings



Lightly oil or grease the bearing seating and locating surfaces for the bearing rings on the adjacent construction.

! Lightly oil the thread of the fixing screws in order to prevent varying friction factors (do not oil or grease screws that will be secured by means of adhesive).

Positioning of slewing rings (Figure 7)

- Place the slewing ring ① on the screw mounting surface of the adjacent construction ②.
- Position the hardness gap (see *Hardness gap on slewing rings*, page 41) such that the bearing ring subjected to point load is offset at 90° to the zone under maximum load.
- Check ③ that the bearing ring to be fitted is in contact with the adjacent construction over its whole width.

Location of slewing rings (Figure 8)

Bearing rings should be located consecutively and without external load:

- in the case of bearings without gear teeth, first fit the bearing ring subjected to point load
- in the case of bearings with gear teeth, first fit the ring without gear teeth.

Location:

- insert the fixing screws ① – with washers if necessary – in the bearing ring to be fitted and tighten in steps to the specified tightening torque M_A according to Table 3, page 46 ②
 - during this process, rotate the unlocated bearing ring ③ several times by a distance corresponding to several screw pitches
 - tighten the screws in a crosswise sequence in order to prevent unacceptable fluctuations in the screw tensioning forces
- screw mount the unlocated bearing ring in the same way as the adjacent construction.
- check the function of the bearing (see *Checking the function*, page 45).

Hydraulic clamping device

If a hydraulic clamping device is used, the clamping forces for the preload must not exceed 90% of the proof stress of the screws

- if hydraulic clamping devices are used, please consult Schaeffler on fitting preload forces.

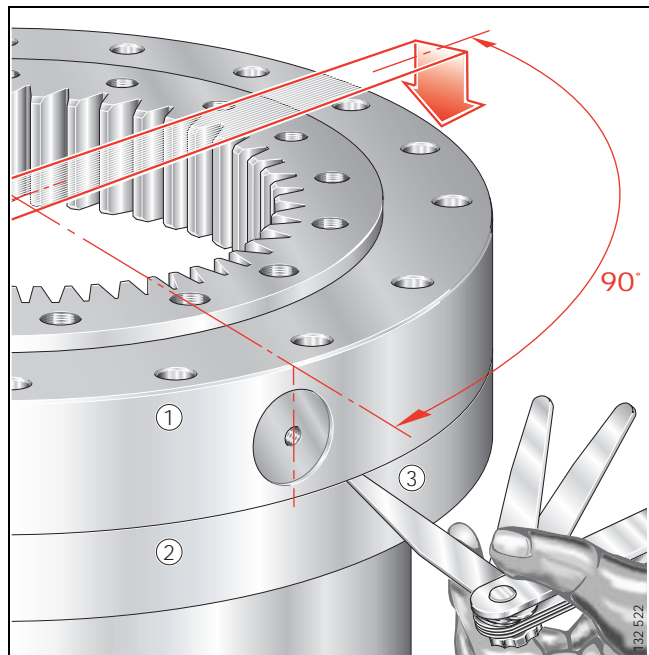

Figure 7 · Positioning of slewing rings

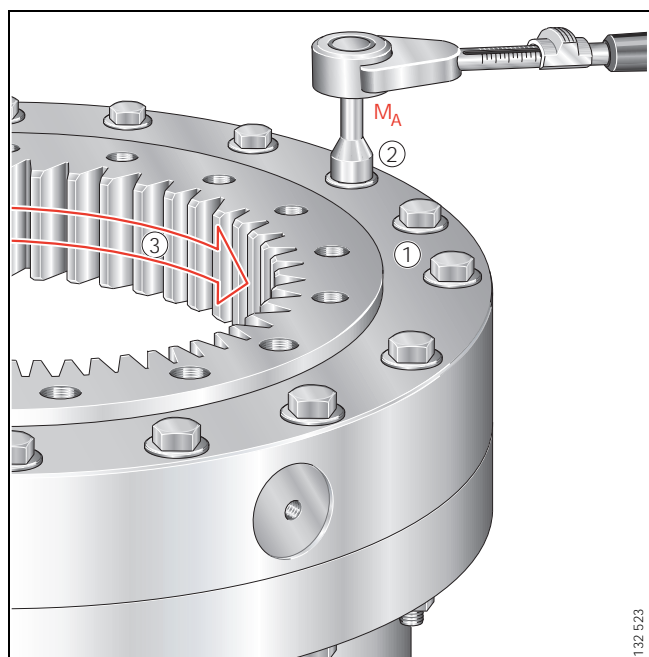

Figure 8 · Screw mounting of slewing rings to the adjacent construction

Fitting

Fitting of slewing rings

Checking and adjustment of tooth flank backlash

In the case of slewing rings with gear teeth, the flank backlash of the gear teeth must be checked and if necessary adjusted after the bearing rings have been screw mounted to the adjacent construction.

Checking (Figure 9):

- determine the flank backlash at the point marked in green on the tooth tip ① – e.g. using a feeler gauge
- adjust the backlash to the nominal value of $0,03$ to $0,04 \times \text{modulus}$
 - this is the standard flank backlash j_n in accordance with DIN 868 and DIN 3960.

Measuring the tilting clearance

The tilting clearance $\delta_{S \text{ tilt}}$ increases during operation. In order to allow the increase to be calculated, the tilting clearance of the fitted bearing must be determined before it is first put into operation.

The tilting clearance $\delta_{S \text{ tilt}}$ consists of:

- the tilting clearance of the bearing when new
- the elastic deformations in the bearing and the adjacent construction
 - mark the measurement point in the main load direction for subsequent checking by measurement ①.
 - note the measured value (see TPI 13).

The measurement point is located between the lower adjacent construction and the bearing ring screw mounted to the upper construction (Figure 10).

The maximum permissible increase in the tilting clearance is shown in Table 2.

Table 2 · Maximum permissible increase in tilting clearance

Bearing type	Maximum permissible increase in tilting clearance $\delta_{S \text{ tilt}}$ mm
Four point contact bearings	$0,035 \cdot D_W^{1)} + 0,6$
Crossed roller bearings	$0,017 \cdot D_W^{1)} - 0,024$

1) D_W is the rolling element diameter in mm.

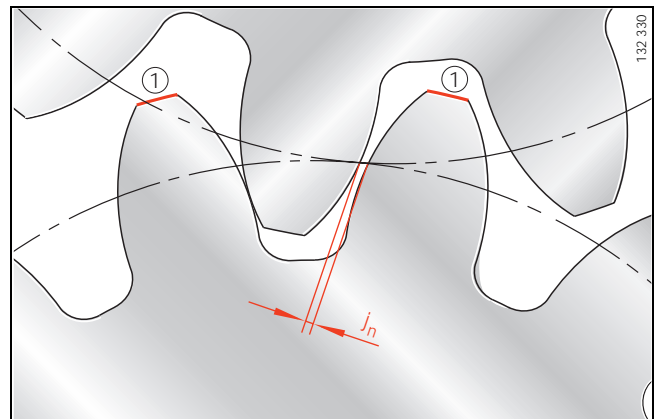

Figure 9 · Checking and adjusting the tooth flank backlash j_n

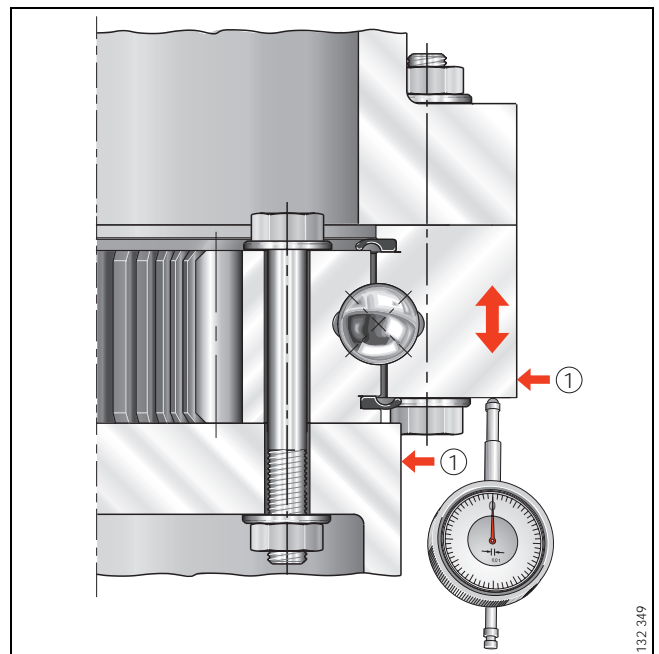



Figure 10 · Measuring the tilting clearance of a fitted bearing

Fitting

Checking the function



Once assembly is complete, the operation of the fitted slewing ring must be checked.

 If the bearing runs irregularly or roughly, or the temperature in the bearing shows an unusual increase, dismantle and check the bearing and reassemble the bearing in accordance with the fitting guidelines in this catalogue or *INA Technical Product Information TPI 13*.

Rotational resistance

The rotational resistance is essentially determined by (see also *Rotational resistance*, page 22):

- the rolling resistance of the rolling elements
- the internal clearance or bearing preload
- the friction of the spacers
- the friction of the seals
- the grease
- a deformed or defective adjacent construction
- errors in fitting of the bearings.

 Due to the preload in the raceway system, the rotational resistance is higher than in a bearing with clearance.

At higher speeds, a high preload can lead to generation of significant heat in the bearing; if necessary tests must be carried out with bearings preloaded to various values.

Bearing temperature

After initial operation, the temperature in the bearing can increase – in the case of grease lubrication, for example, until the grease is evenly distributed in the bearing arrangement.

A further increase or unusually high temperatures may be caused by one of the following:

- the bearing is lubricated using an unsuitable grease
- there is excessive lubricant in the bearing
- the load on the bearing is excessively high
- the bearings are fitted unevenly
- the adjacent construction deviates from the specifications.

Safety checks

 After each period of 500 hours of operation, but at least every six months, check and if necessary correct or replace:

- the condition and tightening torque of the fixing screws
- the tilting clearance.

A failure to follow these instructions can lead to considerable personal injury or damage to property.

The procedure and scope of the safety checks is described in detail in *INA Technical Product Information TPI 13*. This TPI is supplied with slewing rings and can also be requested from Schaeffler.

Fitting

Tightening torques and fitting preload forces for fixing screws

Table 3 · Tightening torques M_A and fitting preload forces F_M for the torque-controlled tightening of fixing screws (set screws)

Fixing screw Dimensions	Tightening torque $M_A^{1)}$ in Nm			Fitting preload $F_M^{2)}$ in kN		
	Grade			Grade		
	8.8	10.9	12.9	8.8	10.9	12.9
M 5	4,9	7	7,6	7	10	11
M 6	7,5	11,7	13,3	9	14	16
M 8	18,9	27,8	32,2	17	25	29
M10	37,5	55,6	63,9	27	40	46
M12	66,7	98,4	111,8	40	59	67
M14	107	155,7	179	55	80	92
M16	166,8	246,9	282,4	75	111	127
M18	230,2	337,8	387,8	92	135	155
M20	328	480,9	553,2	118	173	199
M22	449,5	660,5	758,4	147	216	248
M24	567,1	830,7	954,1	170	249	286
M27	836,9	1227,2	1411,1	223	327	376
M30	1130,1	1663,8	1909,9	271	399	458

¹⁾ M_A according to VDI Guideline 2230 (July 1986) for $\mu_K = 0,08$ and $\mu_G = 0,12$.

²⁾ F_M according to VDI Guideline 2230 (July 1986) for $\mu_G = 0,12$.

Table 4 · Fitting preload forces $F_M^{1)}$ for the use of hydraulic clamping devices (set screws)

Fixing screw Dimensions	Clamping cross-section $A_S^{2)}$ mm ²	Core cross-section $A_{d3}^{2)}$ mm ²	Fitting preload $F_M^{1)}$ for grade		
			8.8 kN	10.9 kN	12.9 kN
M16	157	144,1	90	133,2	155,7
M18	193	175,1	114,3	162,9	190,8
M20	245	225,2	145,8	207	243
M22	303	281,5	180	256,5	301,5
M24	353	324,3	209,7	297	351
M27	459	427,1	274,5	387	450
M30	561	519	333	477	558

¹⁾ $F_M = 0,9 \cdot F_{0,2}$.

²⁾ A_S and A_{d3} and $F_{0,2}$ according to VDI Guideline 2 230.

Product range

Features and dimension tables



Four point contact bearings

with external gear teeth, with internal gear teeth,
without gear teeth



Features

Four point contact bearings

- are units comprising inner and outer rings with a closing plug and securing dowel, rolling elements, spacers, contact seals and lubrication nipples
 - gear teeth on the outer ring, inner ring or without gear teeth
 - bearing rings with through holes or threaded holes for fixing screws
- are suitable in the light series 20 for
 - low to moderate loads and circumferential speeds up to 2 m/s ($n \cdot D_M = 38\,200$), for short periods up to 2,6 m/s ($n \cdot D_M = 49\,700$)
- are suitable in the standard series 20 for
 - moderate loads and circumferential speeds up to 2 m/s ($n \cdot D_M = 38\,200$), for short periods up to 2,6 m/s ($n \cdot D_M = 49\,700$)
- are suitable in the standard series 25 for
 - moderate to heavy loads and circumferential speeds up to 4 m/s ($n \cdot D_M = 76\,400$), for short periods up to 5,2 m/s ($n \cdot D_M = 99\,500$)
- can support axial, radial and tilting moment loads
 - cannot, however, be subjected to loads as high as crossed roller bearings
- are suitable for supported and suspended loads
- are used where lower requirements are placed on the accuracy of the bearing arrangement
- have an internal clearance matched to the series
 - the internal clearance of series VL 20 and VS 20 can be selected
- have contact seals on both sides that protect the raceway system against dust, contamination and moisture
- are greased with a lithium complex soap grease KP2N-20 according to DIN 51 825, but can also be lubricated with oil
- are suitable for operating temperatures from -25 °C to $+80\text{ °C}$
- are very easy to fit since the bearing rings are screw mounted directly to the adjacent construction
 - bearings of series VL 20 are also supplied without holes
- are also available in series **VA, VI, VU** (see *dimension tables*).

Four point contact bearings



VLA 20

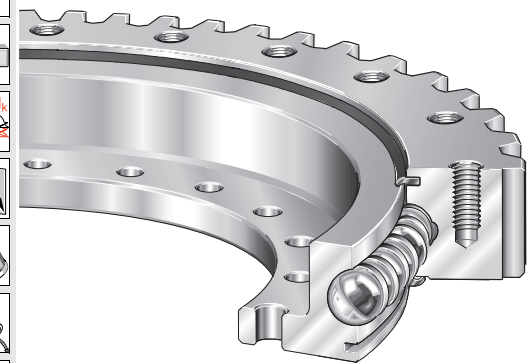

132 388a



52

- light series 20, with external gear teeth
- inner ring in the form of an L-section ring
- balls in accordance with DIN 5 401, plastic spacers
- lubrication nipple on the circumference of the ring without gear teeth
- rolling element pitch circle diameter from 414 mm to 1094 mm



VSA 20, VSA 25

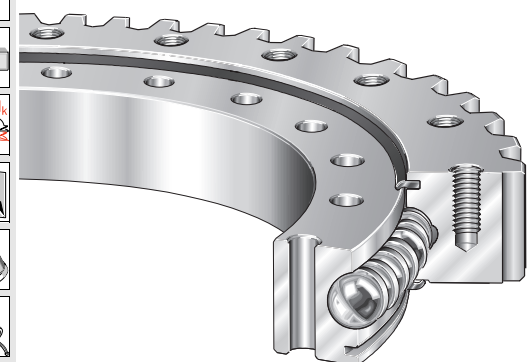

132 389a



58/64

- standard series 20 and 25, with external gear teeth
- balls in accordance with DIN 5 401, plastic spacers
- lubrication nipple on the circumference of the ring without gear teeth
- VSA 20 with rolling element pitch circle diameter from 414 mm to 1094 mm
- VSA 25 with rolling element pitch circle diameter from 755 mm to 1055 mm



VLI 20

132 390a

- light series 20, with internal gear teeth
- outer ring in the form of an L-section ring
- balls in accordance with DIN 5 401, plastic spacers
- lubrication nipple on the circumference of the ring without gear teeth
- rolling element pitch circle diameter from 414 mm to 1094 mm

54

VLU 20

132 391a

- light series 20, without gear teeth
- inner and outer rings in the form of L-section rings
- balls in accordance with DIN 5 401, plastic spacers
- lubrication nipple on the circumference of the outer ring
- rolling element pitch circle diameter from 414 mm to 1094 mm

56

VSI 20, VSI 25

132 392a

- standard series 20 and 25, with internal gear teeth
- balls in accordance with DIN 5 401, plastic spacers
- lubrication nipple on the circumference of the ring without gear teeth
- VSI 20 with rolling element pitch circle diameter from 414 mm to 1094 mm
- VSI 25 with rolling element pitch circle diameter from 755 mm to 1055 mm

60/66

VSU 20, VSU 25

132 393a

- standard series 20 and 25, without gear teeth
- balls in accordance with DIN 5 401, plastic spacers
- lubrication nipple on the circumference of the outer ring
- VSU 20 with rolling element pitch circle diameter from 414 mm to 1094 mm
- VSU 25 with rolling element pitch circle diameter from 755 mm to 1055 mm

62/68

Four point contact bearings

with external gear teeth, with internal gear teeth,
without gear teeth



Accuracy

The following tables give tolerances for slewing rings
(for further tolerances, see the *dimension tables*).

Diameter tolerances

Table 1 · Outside and inside diameter tolerances in accordance with ISO 2 768-m¹⁾

Outside and inside diameter D_a, d_i mm	Tolerance according to ISO 2 768-m mm
incl. 120	$\pm 0,3$
over 120 incl. 400	$\pm 0,5$
over 400 incl. 1000	$\pm 0,8$
over 1000	$\pm 1,2$

¹⁾ Values for VL 20 and VS 20 (rings without gear teeth):
see *dimension tables*.

Table 2 · Tolerances for gap diameter¹⁾

Rolling element diameter (ball) mm	Tolerance for gap diameter $D_i (+), d_a (-)$ mm
10 to 12	0,6
14 to 18	0,8
20 to 25	1
30 to 40	1,5

¹⁾ Values for VL 20 and VS 20: see *dimension tables*.

Table 3 · Tolerances for hole pitch circle diameter

Hole pitch circle diameter L_a, L_i mm	Positional tolerance for fixing holes \oplus mm
incl. 500	$\pm 0,5$
over 500 incl. 1200	$\pm 0,6$

Diameter tolerances for fixing holes in accordance with ISO 273,
"medium".

Height tolerances

Table 4 · Mounting height (H) and individual ring height (h)

Mounting height H		Individual ring height h	
Series	Height tolerance mm	Series	Height tolerance mm
VL 20	$\pm 0,7$ (at preload ^{+0,7} ₋₁)	VL (L-section ring)	-3
VS 20	$\pm 0,6$ (at preload ^{+0,3} ₋₁)	VL (gear ring)	$\pm 0,3$ (at preload ^{+0,3} _{-0,65})
VS 25	$\pm 0,6$	VS 20	$\pm 0,3$ (at preload ^{+0,3} _{-0,65})
		VS 25	$\pm 0,3$

Centring devices

Table 5 · ISO tolerance series

Centring diameter mm	IT8	IT7
	Outside diameter (-) Inside diameter (+) mm	
over 120 incl. 180	0,06	0,04
over 180 incl. 250	0,07	0,05
over 250 incl. 315	0,08	0,05
over 315 incl. 400	0,09	0,06
over 400 incl. 500	0,1	0,06
over 500 incl. 630	0,11	0,07
over 630 incl. 800	0,13	0,08
over 800 incl. 1000	0,14	0,09
over 1000 incl. 1250	0,17	0,11

Surface quality

Table 6 · Surface quality

Machined surfaces	Mean roughness depth R_z μm
Outside surfaces and holes	100
VL 20 (L-section rings in some cases)	raw
Centring devices and seal running surfaces	25
Gear teeth, grade 12	100
Gear teeth, grade 10	25

Gear teeth tolerances

Table 7 · Tolerances of tip pitch circle diameter for gear teeth

Tip pitch circle diameter D_a, d_i mm	Tolerance External gear teeth D_a (-) Internal gear teeth d_i (+) mm
incl. 500	0,4
over 500 incl. 1200	0,7

Tolerances for fixing holes (Figure 1)

Table 8 · Tolerances for fixing holes

Thread	d_B	d_s	t_s		Thread runout	
			Type K, for screws to DIN 912	Type J, for screws to DIN 6912	Rule	short
M 6	6,6 +0,25	11+0,25	6,8 +0,4	4,8 +0,4	5,1	3,2
M 8	9 +0,25	15+0,25	9 +0,4	6 +0,4	6,2	3,9
M10	11 +0,25	18+0,25	11 +0,4	7,5 +0,4	7,3	4,6
M12	(13,5) ¹ +0,25	20+0,3	13 +0,4	8,5 +0,4	8,3	5,2
	14 +0,25	20+0,3	13 +0,4	8,5 +0,4	8,3	5,2
M14	(15,5) ¹ +0,25	24+0,3	15 +0,4	9,5 +0,4	9,3	5,8
	16 +0,25	24+0,3	15 +0,4	9,5 +0,4	9,3	5,8
M16	(17,5) ¹ +0,25	26+0,25	17,5 +0,4	11,5 +0,4	9,3	5,8
	18 +0,25	26+0,25	17,5 +0,4	11,5 +0,4	9,3	5,8
M18	20 +0,3	30+0,3	19,5 +0,4	12,5 +0,4	11,2	7
M20	22 +0,3	33+0,4	21,5 +0,4	13,5 +0,4	11,2	7
M24	26 +0,3	40+0,4	25,5 +0,4	15,5 +0,4	13	8,2

1) The value d_B is valid for a hole with counterbore and drilled out for a thread.

Table 9 · Permissible runout error for gear teeth (N)¹ in accordance with DIN 3962

Series	Position ²⁾	Runout of gear teeth ³⁾ mm
VL 20 and VS 20	①	0,32
	②, ③, ④	0,36
	⑤, ⑥, ⑦	0,45
VSA 25	①, ②	0,28
	③, ④	0,32
VSI 25	①, ②, ③, ④	0,28
VA	①	0,2
	②, ③, ④	0,22
VI	①, ②	0,2
	③	0,22

1) (N) indicates normalised gear teeth.

2) For the associated bearing, see the corresponding *dimension table*.

3) In contrast to DIN 3962, the runout of the gear teeth is defined as the wall thickness variation between the rolling element pitch circle diameter and the pitch circle diameter of the gear teeth.

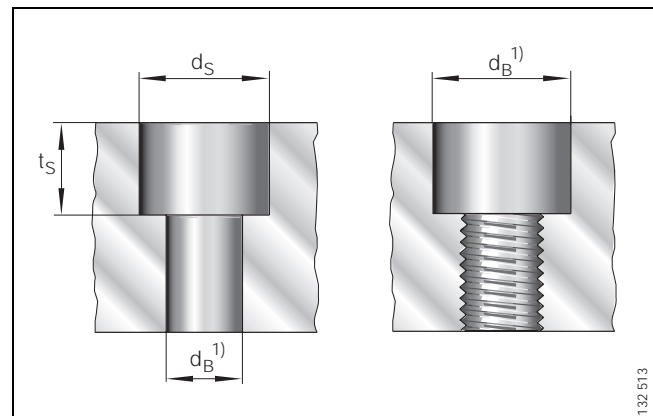
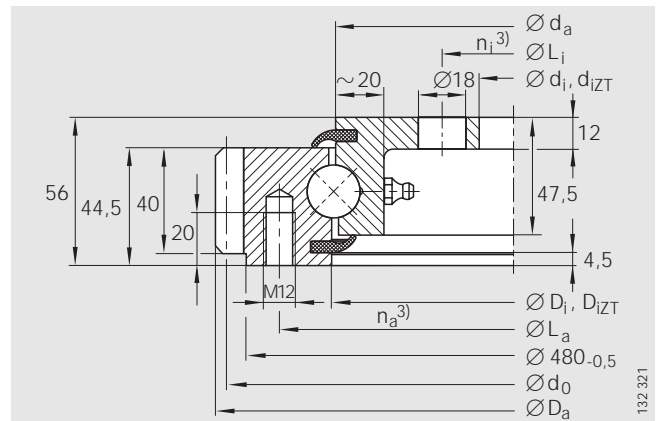

Figure 1 · Tolerances for fixing holes

Four point contact bearings

Light series 20
external gear teeth

Series VLA



VLA 200414 N

no. ①

4 taper type lubrication nipples, DIN 71412-A S8×1,
arranged evenly about the circumference

Dimension table · Dimensions in mm

Designation	no. ¹⁾	Mass ≈kg	Dimensions						Fixing holes ⁵⁾			
			D_a	d_i	d_{iZT} ²⁾ +IT8	D_i	D_{iZT} ²⁾ +IT8	d_a	L_a	n_a ³⁾	L_i	n_i ³⁾
VLA 20 0414 N	①	29,5	503,3	$304^{+0,5}$	306	$415,5^{+0,5}$	417	$412,5_{-0,5}$	455	10	332	12
VLA 20 0544 N	②	41,5	640,3	$434^{+0,5}$	436	$545,5^{+0,5}$	547	$542,5_{-0,5}$	585	14	462	14
VLA 20 0644 N	③	48,5	742,3	$534^{+0,6}$	536	$645,5^{+0,6}$	647	$642,5_{-0,6}$	685	16	562	16
VLA 20 0744 N	④	54,5	838,1	$634^{+0,6}$	636	$745,5^{+0,6}$	747	$742,5_{-0,6}$	785	18	662	16
VLA 20 0844 N	⑤	65,5	950,1	$734^{+0,6}$	736	$845,5^{+0,6}$	847	$842,5_{-0,6}$	885	18	762	18
VLA 20 0944 N	⑥	71,5	1046,1	$834^{+0,7}$	836	$945,5^{+0,7}$	947	$942,5_{-0,7}$	985	20	862	20
VLA 20 1094 N	⑦	83,5	1198,1	$984^{+0,7}$	986	$1095,5^{+0,7}$	1097	$1092,5_{-0,7}$	1135	22	1012	20

1) Number of associated curve,
see static limiting load diagram *Raceway and Fixing screws*.

2) Bearing with centring (suffix ZT), for centring lengths see *dimension drawing*.

3) Number of holes per ring.

4) Maximum radial load. For load carrying capacity of screws see section *Fixing screws*, page 20.

5) Bearings are also available without holes in the bearing rings.
Example of ordering designation: VLA 20 0544 N SVAR 0080.

Radial clearance and axial tilting clearance

Internal clearance class/preload	Radial clearance	Axial tilting clearance
– (standard design)	0 incl. 0,5	0 incl. 0,7
RL3 (internal clearance class 3)	0,25 incl. 0,5	0,4 incl. 0,7
RL2 (internal clearance class 2)	0,1 incl. 0,3	0,17 incl. 0,53
RL1 (internal clearance class 1)	0 incl. 0,1	0 incl. 0,21
RL0 (internal clearance class 0)	0 incl. 0,05	0 incl. 0,08
VSP (bearing with preload)	0	0

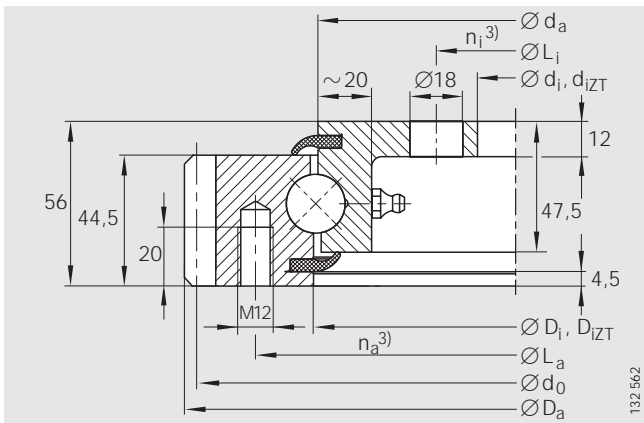

VLA 20
 no. ② to ⑦
 4 taper type lubrication nipples, DIN 71412-A S8×1, arranged
 evenly about the circumference, no. ② and ⑤ ≈ uniform

Fixing screws $F_{r \text{ perm}}$ (friction locking) ⁴⁾ kN	Gear teeth			Tooth force		Basic load ratings			
	d_0	m	z	$F_{z \text{ norm}}$	$F_{z \text{ max}}$	axial		radial	
						dyn. C_a kN	stat. C_{0a} kN	dyn. C_r kN	stat. C_{0r} kN
41,3	495	5	99	15,9	23,6	169	295	111	110
57,8	630	6	105	21,3	31,5	188	385	123	145
66,1	732	6	122	21,3	31,5	200	455	131	171
74,3	828	6	138	21,3	31,5	211	530	138	198
74,3	936	8	117	28,3	42	222	600	145	224
82,6	1032	8	129	28,3	42	231	670	151	250
90,9	1184	8	148	28,3	42	244	770	160	290

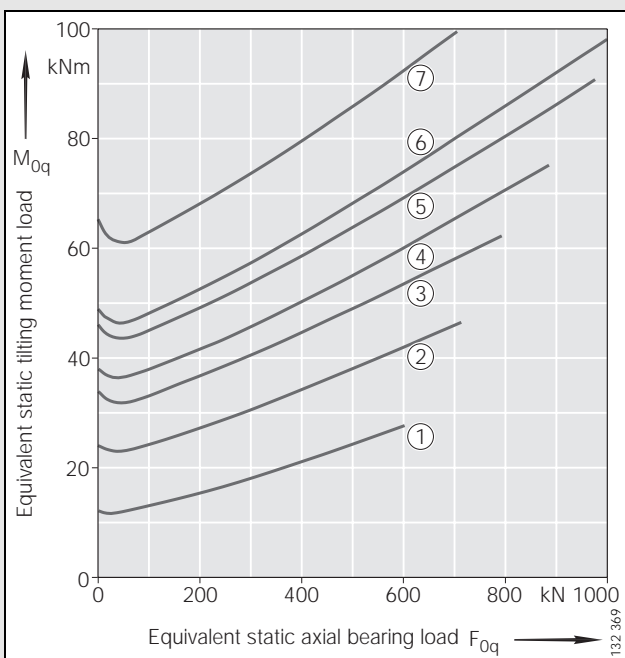

Static limiting load diagram
 Fixing screws (supported load)

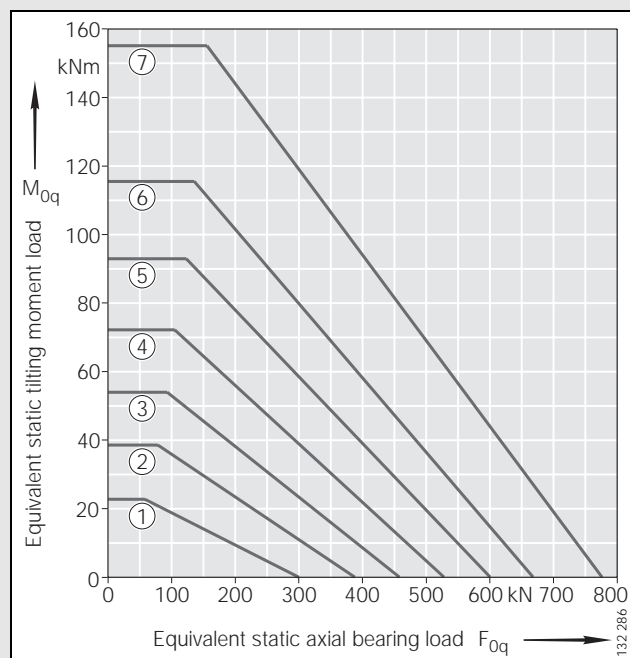

Static limiting load diagram
 Raceway (supported load)

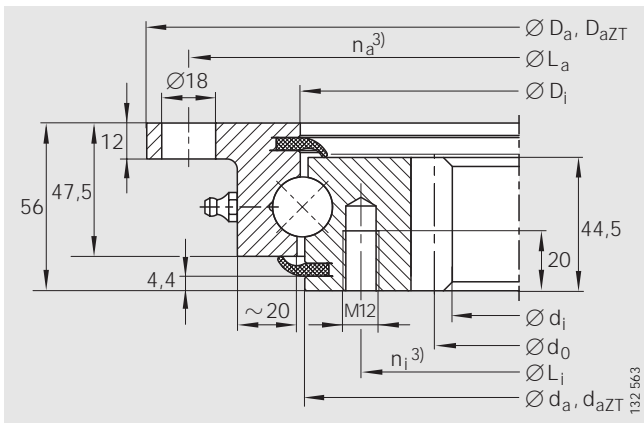

VLI 20
 no. ② to ⑦
 4 taper type lubrication nipples, DIN 71412-A S8×1, arranged evenly about the circumference; no. ② and ⑤ ≈ uniform



Fixing screws $F_{r \text{ perm}}$ (friction locking) ⁴⁾ kN	Gear teeth			Tooth force		Basic load ratings			
	d_0	m	z	$F_{z \text{ norm}}$	$F_{z \text{ max}}$	axial		radial	
						dyn. C_a kN	stat. C_{0a} kN	dyn. C_r kN	stat. C_{0r} kN
49,6	335	5	67	17,7	26,2	169	295	111	110
66,1	456	6	76	23,7	35	188	385	123	145
74,3	558	6	93	23,7	35	200	455	131	171
82,6	660	6	110	23,7	35	211	530	138	198
82,6	752	8	94	31,4	46,7	222	600	145	224
90,9	856	8	107	31,4	46,7	231	670	151	250
99,1	1000	8	125	31,4	46,7	244	770	160	290

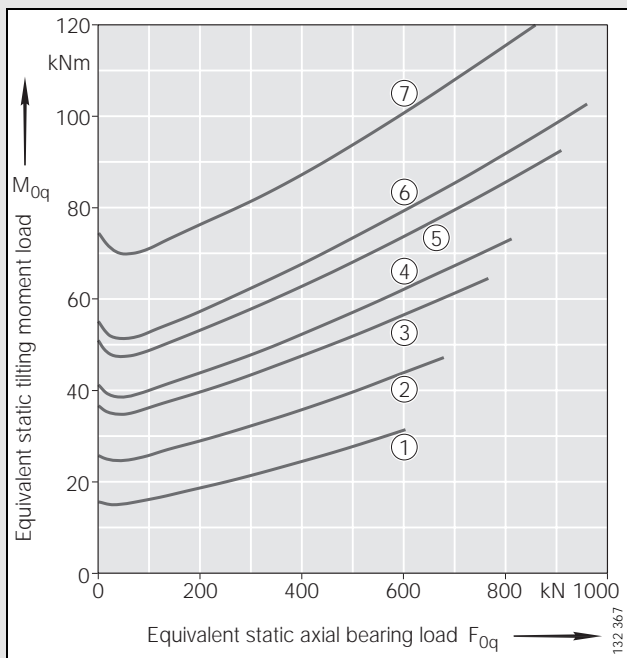

Static limiting load diagram
 Fixing screws (supported load)

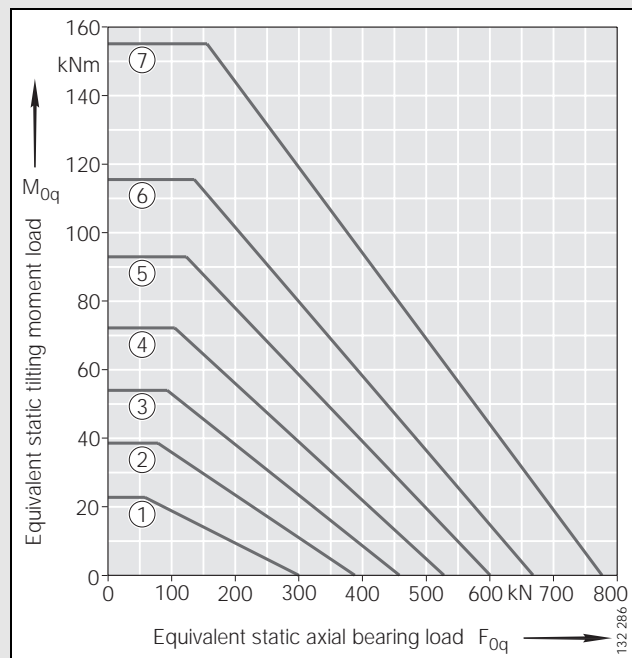

Static limiting load diagram
 Raceway (supported load)

Four point contact bearings

Light series 20
without gear teeth

Series VLU

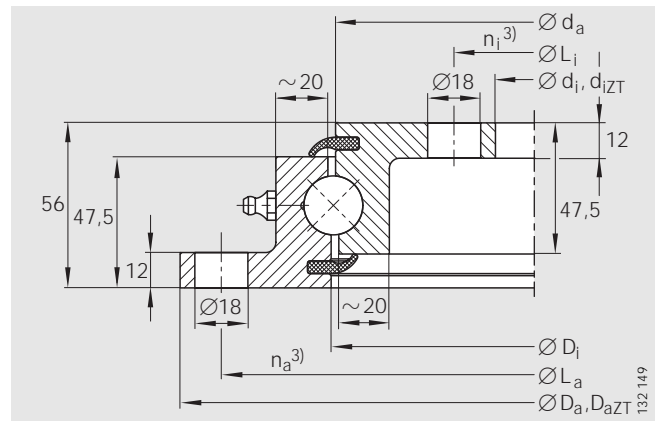

VLU 20
4 taper type lubrication nipples, DIN 71412-A S8×1,
arranged evenly about the circumference;
no. ② and ⑤ ≈ uniform

Dimension table · Dimensions in mm

Designation	no. ¹⁾	Mass ≈kg	Dimensions					
			D_a	D_{aZT} ²⁾ -IT8	d_i	d_{iZT} ²⁾ +IT8	D_i	d_a
VLU 20 0414	①	23,5	518 _{-0,5}	516	304 ^{+0,5}	306	415,5 ^{+0,5}	412,5 _{-0,5}
VLU 20 0544	②	31	648 _{-0,5}	646	434 ^{+0,5}	436	545,5 ^{+0,5}	542,5 _{-0,5}
VLU 20 0644	③	36,5	748 _{-0,6}	746	534 ^{+0,6}	536	645,5 ^{+0,6}	642,5 _{-0,6}
VLU 20 0744	④	42,5	848 _{-0,6}	846	634 ^{+0,6}	636	745,5 ^{+0,6}	742,5 _{-0,6}
VLU 20 0844	⑤	48	948 _{-0,6}	946	734 ^{+0,6}	736	845,5 ^{+0,6}	842,5 _{-0,6}
VLU 20 0944	⑥	54	1048 _{-0,7}	1046	834 ^{+0,7}	836	945,5 ^{+0,7}	942,5 _{-0,7}
VLU 20 1094	⑦	62,5	1198 _{-0,7}	1196	984 ^{+0,7}	986	1095,5 ^{+0,7}	1092,5 _{-0,7}

1) Number of associated curve,
see static limiting load diagram *Raceway and Fixing screws*.

2) Bearing with centring (suffix ZT), for centring lengths see *dimension drawing*.

3) Number of holes per ring.

4) Maximum radial load. For load carrying capacity of screws see section *Fixing screws*, page 20.

5) Bearings are also available without holes in the bearing rings.
Example of ordering designation: VLU 20 0544 SVAR 0080.

Radial clearance and axial tilting clearance

Internal clearance class/preload	Radial clearance	Axial tilting clearance
- (standard design)	0 incl. 0,5	0 incl. 0,7
RL3 (internal clearance class 3)	0,25 incl. 0,5	0,4 incl. 0,7
RL2 (internal clearance class 2)	0,1 incl. 0,3	0,17 incl. 0,53
RL1 (internal clearance class 1)	0 incl. 0,1	0 incl. 0,21
RL0 (internal clearance class 0)	0 incl. 0,05	0 incl. 0,08
VSP (bearing with preload)	0	0



Fixing holes ⁵⁾				Fixing screws $F_{r, perm}$ (friction locking) ⁴⁾ kN	Basic load ratings			
L_a	$n_a^{3)}$	L_i	$n_i^{3)}$		axial		radial	
					dyn. C_a kN	stat. C_{0a} kN	dyn. C_r kN	stat. C_{0r} kN
490	8	332	12	55	169	295	111	110
620	10	462	14	72,5	188	385	123	145
720	12	562	16	85,5	200	455	131	171
820	12	662	16	93,6	211	530	138	198
920	14	762	18	109,2	222	600	145	224
1020	16	862	20	124,8	231	670	151	250
1170	16	1012	20	124,8	244	770	160	290

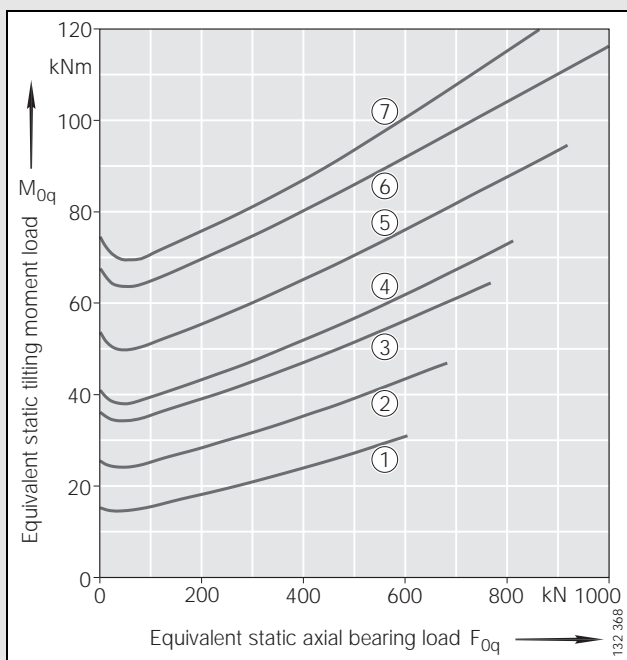

Static limiting load diagram
Fixing screws (supported load)

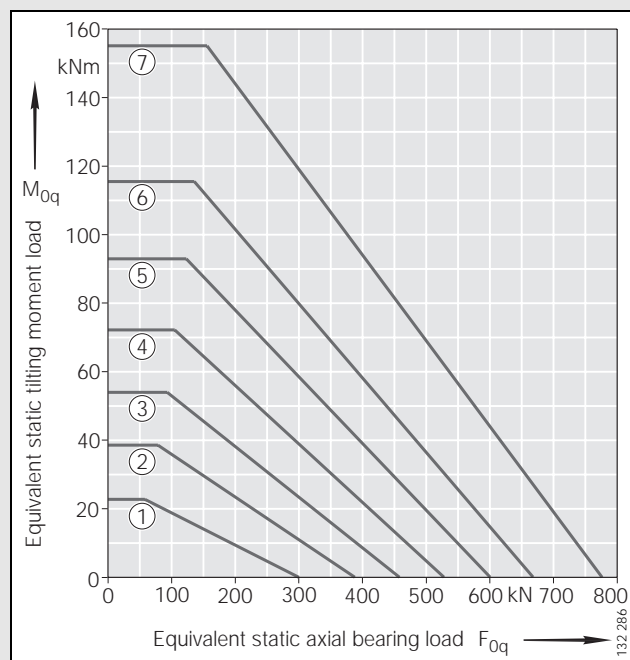

Static limiting load diagram
Raceway (supported load)

Four point contact bearings

Standard series 20
external gear teeth

Series VSA

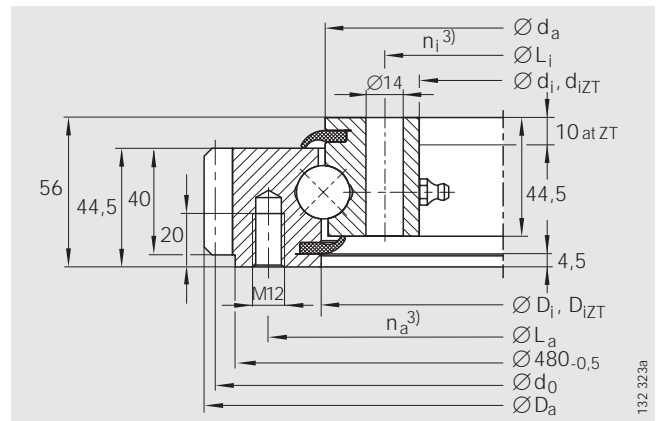

VSA 200414 N

no. ①

4 taper type lubrication nipples, DIN 71412-A S8×1,
arranged evenly about the circumference

Dimension table · Dimensions in mm

Designation	no. ¹⁾	Mass ≈kg	Dimensions						Fixing holes			
			D_a	d_i	$d_{iZT}^{2)}$ +IT8	D_i	$D_{iZT}^{2)}$ +IT8	d_a	L_a	$n_a^{3)}$	L_i	$n_i^{3)}$
VSA 20 0414 N	①	31	503,3	$342^{+0,5}$	344	$415,5^{+0,5}$	417	$412,5_{-0,5}$	455	20	368	24
VSA 20 0544 N	②	43	640,3	$472^{+0,5}$	474	$545,5^{+0,5}$	547	$542,5_{-0,5}$	585	28	498	32
VSA 20 0644 N	③	52	742,3	$572^{+0,6}$	574	$645,5^{+0,6}$	647	$642,5_{-0,6}$	685	32	598	36
VSA 20 0744 N	④	59	838,1	$672^{+0,6}$	674	$745,5^{+0,6}$	747	$742,5_{-0,6}$	785	36	698	40
VSA 20 0844 N	⑤	71	950,1	$772^{+0,6}$	774	$845,5^{+0,6}$	847	$842,5_{-0,6}$	885	36	798	40
VSA 20 0944 N	⑥	77	1046,1	$872^{+0,7}$	874	$945,5^{+0,7}$	947	$942,5_{-0,7}$	985	40	898	44
VSA 20 1094 N	⑦	91	1198,1	$1022^{+0,7}$	1024	$1095,5^{+0,7}$	1097	$1092,5_{-0,7}$	1135	44	1048	48

1) Number of associated curve,
see static limiting load diagram *Raceway and Fixing screws*.

2) Bearing with centring (suffix ZT), for centring lengths see *dimension drawing*.

3) Number of holes per ring.

4) Maximum radial load. For load carrying capacity of screws see section *Fixing screws*, page 20.

Radial clearance and axial tilting clearance

Internal clearance class/preload	Radial clearance	Axial tilting clearance
– (standard design)	0 incl. 0,3	0 incl. 0,53
RL2 (internal clearance class 2)	0,1 incl. 0,3	0,17 incl. 0,53
RL1 (internal clearance class 1)	0 incl. 0,1	0 incl. 0,21
RL0 (internal clearance class 0)	0 incl. 0,05	0 incl. 0,08
VSP (bearing with preload)	0	0

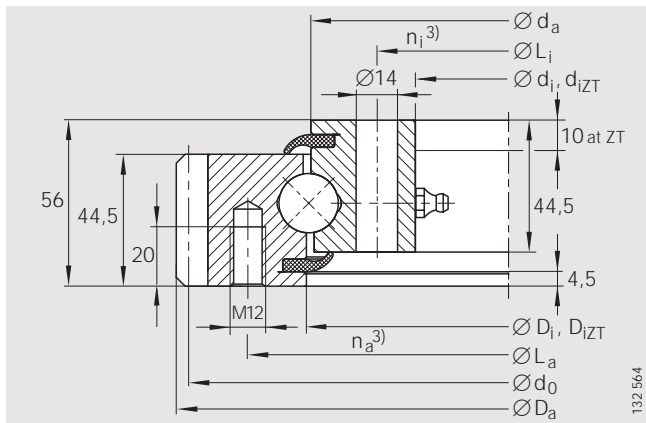

VSA 20
no. ② to ⑦
4 taper type lubrication nipples, DIN 71412-A S8×1,
arranged evenly about the circumference

Fixing screws $F_{r \text{ perm}}$ (friction locking) ⁴⁾ kN	Gear teeth			Tooth force		Basic load ratings			
	d_0	m	z	$F_{z \text{ norm}}$ kN	$F_{z \text{ max}}$ kN	axial		radial	
						dyn. C_a kN	stat. C_{0a} kN	dyn. C_r kN	stat. C_{0r} kN
82,6	495	5	99	15,9	23,6	169	560	111	248
115,6	630	6	105	21,3	31,5	188	740	123	325
132,2	732	6	122	21,3	31,5	200	880	131	385
148,7	828	6	138	21,3	31,5	211	1010	138	445
148,7	936	8	117	28,3	42	222	1150	145	510
165,2	1032	8	129	28,3	42	231	1280	151	570
181,7	1184	8	148	28,3	42	244	1490	160	660

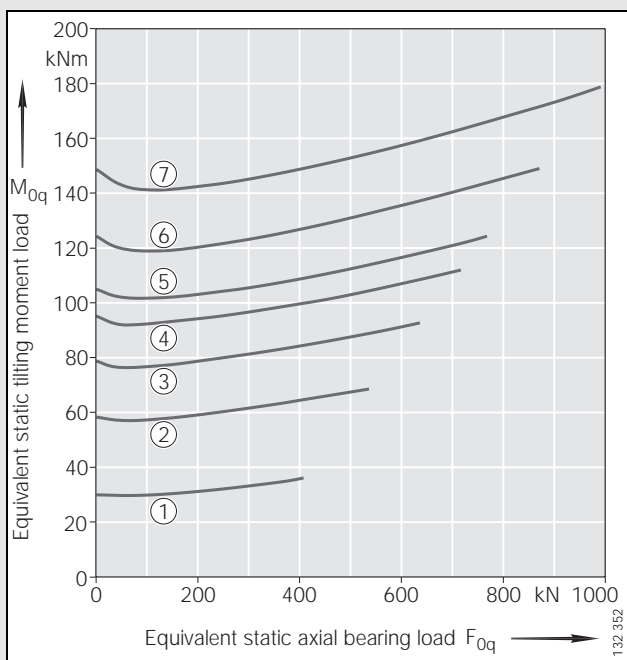

Static limiting load diagram
Fixing screws (supported load)

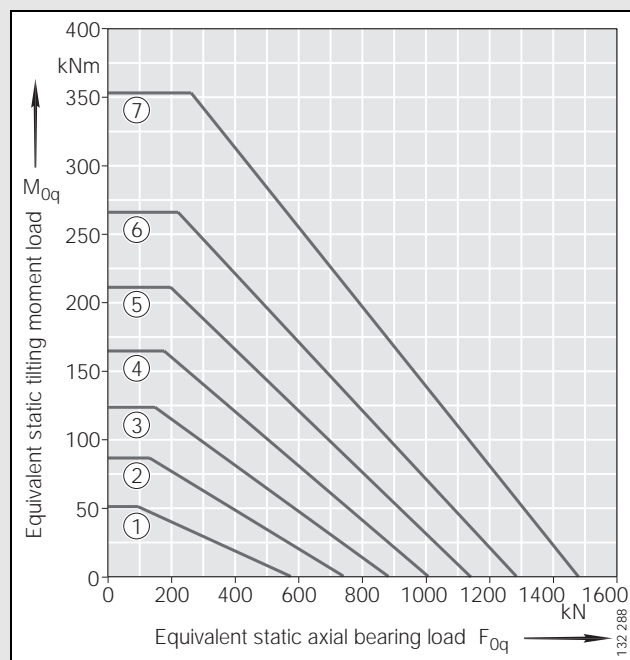

Static limiting load diagram
Raceway (supported load)

Four point contact bearings

Standard series 20
internal gear teeth

Series VSI

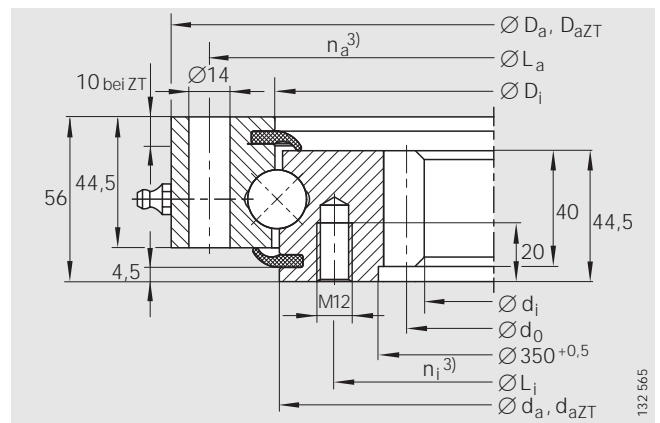

VSI 20 0414 N

no. ①

4 taper type lubrication nipples, DIN 71 412-A S8×1, arranged evenly about the circumference

Dimension table · Dimensions in mm

Designation	no. ¹⁾	Mass ≈kg	Dimensions						Fixing holes			
			D _a	D _{aZT} ²⁾ -IT8	d _i	D _i	d _a	d _{aZT} ²⁾ -IT8	L _a	n _a ³⁾	L _i	n _i ³⁾
VSI 20 0414 N	①	31	486 _{-0,5}	484	325	415,5 ^{+0,5}	412,5 _{-0,5}	411	460	24	375	24
VSI 20 0544 N	②	42	616 _{-0,5}	614	444	545,5 ^{+0,5}	542,5 _{-0,5}	541	590	32	505	32
VSI 20 0644 N	③	50	716 _{-0,6}	714	546	645,5 ^{+0,6}	642,5 _{-0,6}	641	690	36	605	36
VSI 20 0744 N	④	58	816 _{-0,6}	814	648	745,5 ^{+0,6}	742,5 _{-0,6}	741	790	40	705	40
VSI 20 0844 N	⑤	69	916 _{-0,6}	914	736	845,5 ^{+0,6}	842,5 _{-0,6}	841	890	40	805	40
VSI 20 0944 N	⑥	76	1016 _{-0,7}	1014	840	945,5 ^{+0,7}	942,5 _{-0,7}	941	990	44	905	44
VSI 20 1094 N	⑦	91	1166 _{-0,7}	1164	984	1095,5 ^{+0,7}	1092,5 _{-0,7}	1091	1140	48	1055	48

1) Number of associated curve, see static limiting load diagram *Raceway and Fixing screws*.

2) Bearing with centring (suffix ZT), for centring lengths see *dimension drawing*.

3) Number of holes per ring.

4) Maximum radial load. For load carrying capacity of screws see section *Fixing screws*, page 20.

Radial clearance and axial tilting clearance

Internal clearance class/preload	Radial clearance	Axial tilting clearance
- (standard design)	0 incl. 0,3	0 incl. 0,53
RL2 (internal clearance class 2)	0,1 incl. 0,3	0,17 incl. 0,53
RL1 (internal clearance class 1)	0 incl. 0,1	0 incl. 0,21
RL0 (internal clearance class 0)	0 incl. 0,05	0 incl. 0,08
VSP (bearing with preload)	0	0

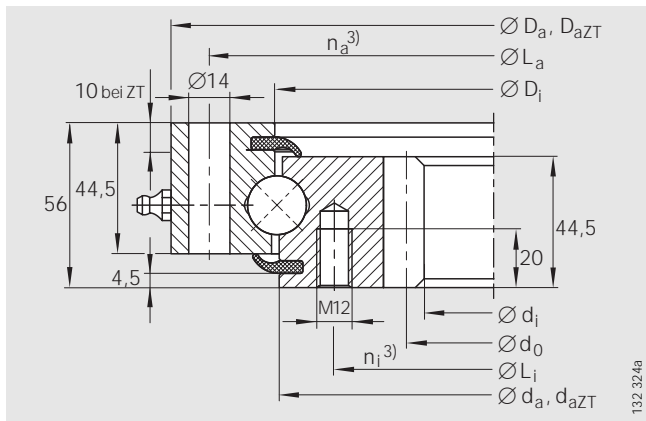

VSI 20
 no. ② to ⑦
 4 taper type lubrication nipples, DIN 71412-A S8×1,
 arranged evenly about the circumference



Fixing screws $F_{r \text{ perm}}$ (friction locking) ⁴⁾ kN	Gear teeth			Tooth force		Basic load ratings			
	d_0	m	z	$F_{z \text{ norm}}$	$F_{z \text{ max}}$	axial		radial	
						dyn. C_a kN	stat. C_{0a} kN	dyn. C_r kN	stat. C_{0r} kN
99,1	335	5	67	17,7	26,2	169	560	111	248
132,2	456	6	76	23,7	35	188	740	123	325
148,7	558	6	93	23,7	35	200	880	131	385
165,2	660	6	110	23,7	35	211	1010	138	445
165,2	752	8	94	31,4	46,7	222	1150	145	510
181,7	856	8	107	31,4	46,7	231	1280	151	570
198,2	1000	8	125	31,4	46,7	244	1490	160	660

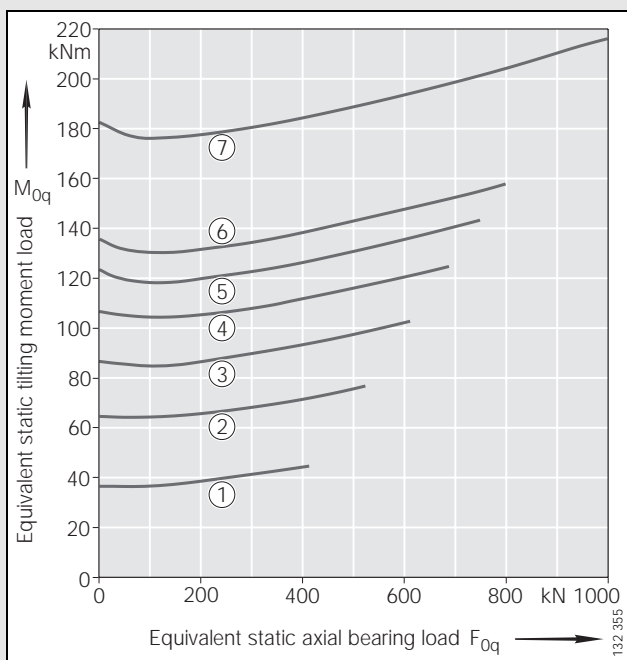

Static limiting load diagram
 Fixing screws (supported load)

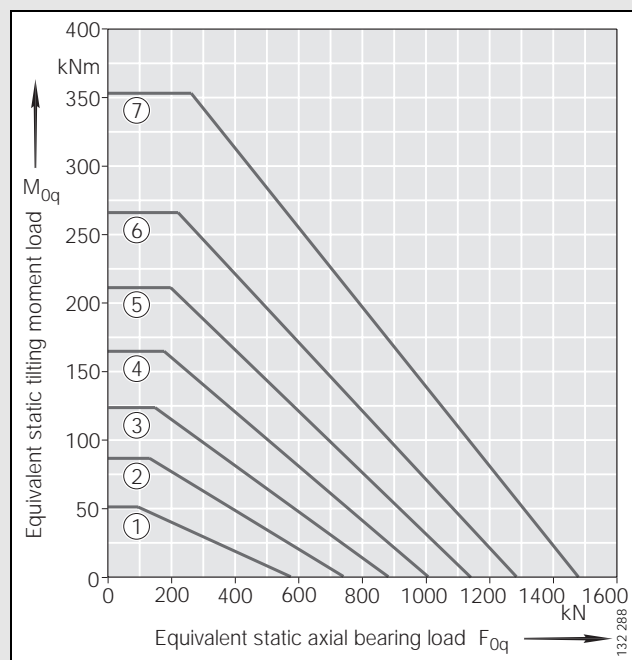

Static limiting load diagram
 Raceway (supported load)

Four point contact bearings

Standard series 20
without gear teeth

Series VSU

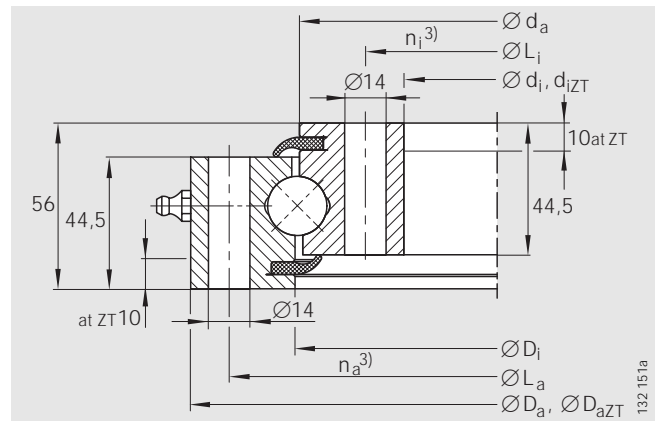

VSU 20
4 taper type lubrication nipples, DIN 71412-A S8×1,
arranged evenly about the circumference

Dimension table · Dimensions in mm

Designation	no. ¹⁾	Mass ≈kg	Dimensions					
			D _a	D _{aZT} ²⁾ -IT8	d _i	d _{iZT} ²⁾ +IT8	D _i	d _a
VSU 200414	①	29	486 _{-0,5}	484	342 ^{+0,5}	344	415,5 ^{+0,5}	412,5 _{-0,5}
VSU 200544	②	37	616 _{-0,5}	614	472 ^{+0,5}	474	545,5 ^{+0,5}	542,5 _{-0,5}
VSU 200644	③	44	716 _{-0,6}	714	572 ^{+0,6}	574	645,5 ^{+0,6}	642,5 _{-0,6}
VSU 200744	④	52	816 _{-0,6}	814	672 ^{+0,6}	674	745,5 ^{+0,6}	742,5 _{-0,6}
VSU 200844	⑤	60	916 _{-0,6}	914	772 ^{+0,6}	774	845,5 ^{+0,6}	842,5 _{-0,6}
VSU 200944	⑥	67	1016 _{-0,7}	1014	872 ^{+0,7}	874	945,5 ^{+0,7}	942,5 _{-0,7}
VSU 201094	⑦	77	1166 _{-0,7}	1164	1022 ^{+0,7}	1024	1095,5 ^{+0,7}	1092,5 _{-0,7}

1) Number of associated curve,
see static limiting load diagram *Raceway and Fixing screws*.

2) Bearing with centring (suffix ZT), for centring lengths see *dimension drawing*.

3) Number of holes per ring.

4) Maximum radial load. For load carrying capacity of screws see section *Fixing screws*, page 20.

Radial clearance and axial tilting clearance

Internal clearance class/preload	Radial clearance	Axial tilting clearance
- (standard design)	0 incl. 0,3	0 incl. 0,53
RL2 (internal clearance class 2)	0,1 incl. 0,3	0,17 incl. 0,53
RL1 (internal clearance class 1)	0 incl. 0,1	0 incl. 0,21
RL0 (internal clearance class 0)	0 incl. 0,05	0 incl. 0,08
VSP (bearing with preload)	0	0



Fixing holes				Fixing screws $F_{r,perm}$ (friction locking) ⁴⁾ kN	Basic load ratings			
L_a	$n_a^{3)}$	L_i	$n_i^{3)}$		axial		radial	
				dyn. C_a kN	stat. C_{0a} kN	dyn. C_r kN	stat. C_{0r} kN	
460	24	368	24	99,1	169	560	111	248
590	32	498	32	132,2	188	740	123	325
690	36	598	36	148,7	200	880	131	385
790	40	698	40	165,2	211	1010	138	445
890	40	798	40	165,2	222	1150	145	510
990	44	898	44	181,7	231	1280	151	570
1140	48	1048	48	198,2	244	1490	160	660

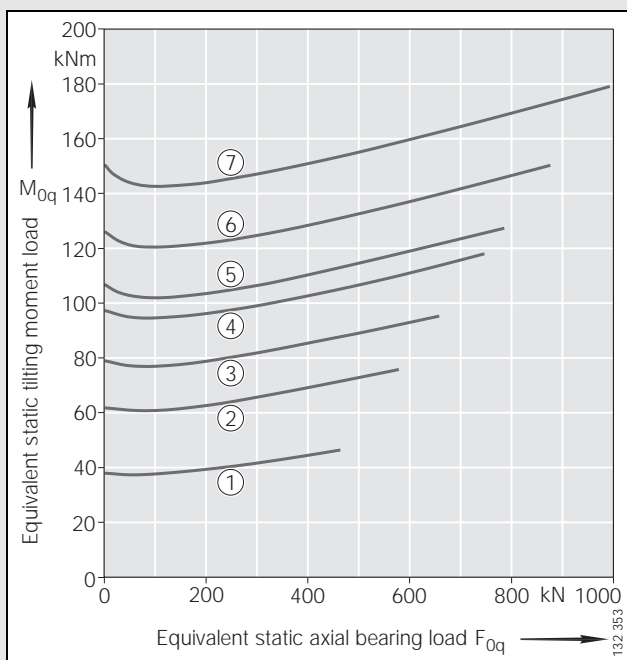

Static limiting load diagram
Fixing screws (supported load)

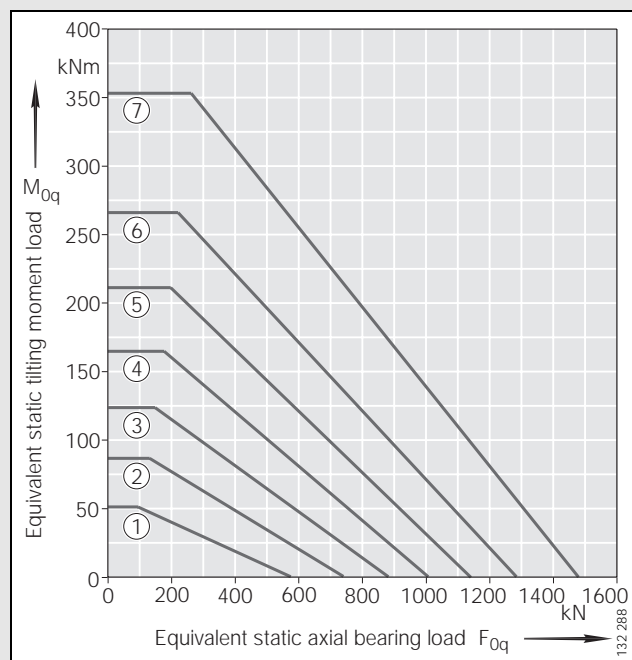

Static limiting load diagram
Raceway (supported load)

Four point contact bearings

Standard series 25
external gear teeth

Series VSA

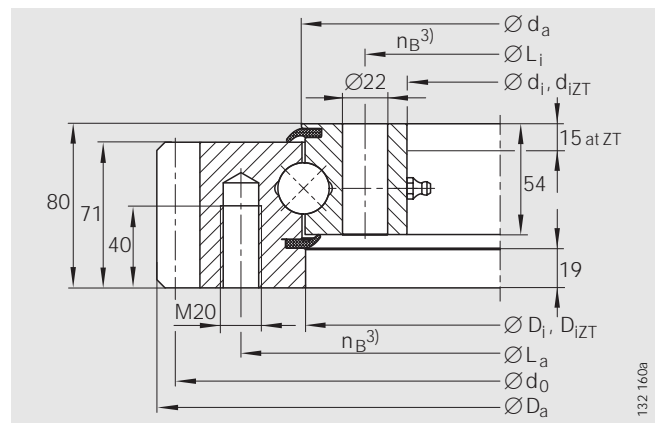

VSA 25

4 taper type lubrication nipples, DIN 71412-A M10×1,
no. ① and ② arranged evenly about the circumference;
no. ③ and ④ ≈ arranged evenly about the circumference

Dimension table · Dimensions in mm

Designation	no. ¹⁾	Mass ≈kg	Dimensions						Fixing holes			Fixing screws $F_{r\ per m}$ (friction locking) ⁴⁾ kN
			D_a	d_i	$d_{iZT}^{(2)}$ +IT8	D_i	$D_{iZT}^{(2)}$ +IT8	d_a	L_a	L_i	$n_B^{(3)}$	
VSA 25 0755 N	①	128	898	655	657	753	755	757	816	695	24	290,4
VSA 25 0855 N	②	145	997	755	757	853	855	857	916	795	28	338,8
VSA 25 0955 N	③	155	1096	855	857	953	955	957	1016	895	30	363
VSA 25 1055 N	④	171	1198	955	957	1053	1055	1057	1116	995	30	363

¹⁾ Number of associated curve,
see static limiting load diagram *Raceway* and *Fixing screws*.

²⁾ Bearing with centring (suffix ZT), for centring lengths see *dimension drawing*.

³⁾ Number of holes per ring.

⁴⁾ Maximum radial load. For load carrying capacity of screws see section *Fixing screws*, page 20.



Gear teeth			Tooth force		Basic load ratings				Internal clearance	
d ₀	m	z	F _{Z norm} kN	F _{Z max} kN	axial		radial		Radial clearance	Axial tilting clearance
					dyn. C _a kN	stat. C _{0a} kN	dyn. C _r kN	stat. C _{0r} kN		
882	9	98	55,1	80,2	460	2250	300	1010	0,03 incl. 0,13	0,05 incl. 0,24
981	9	109	55,1	80,2	485	2550	315	1150	0,03 incl. 0,13	0,05 incl. 0,24
1080	9	120	55,1	80,2	500	2850	330	1280	0,03 incl. 0,13	0,05 incl. 0,24
1180	10	118	61,2	89	520	3150	340	1410	0,03 incl. 0,13	0,05 incl. 0,24

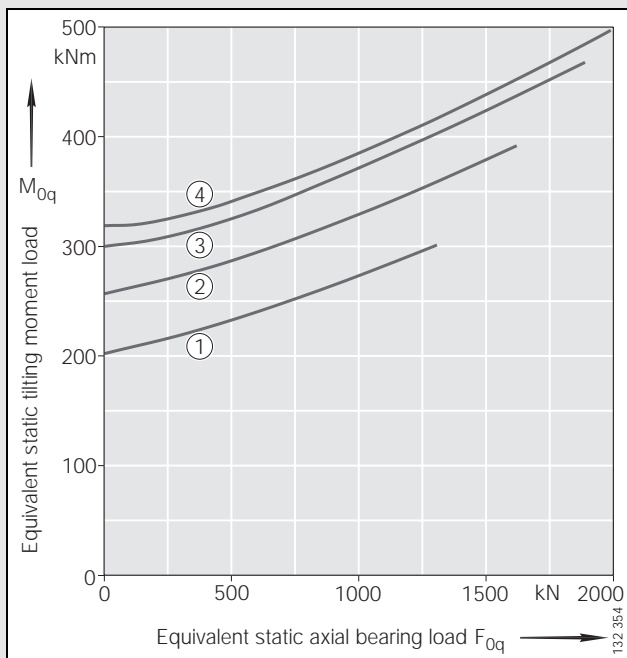

Static limiting load diagram
Fixing screws (supported load)

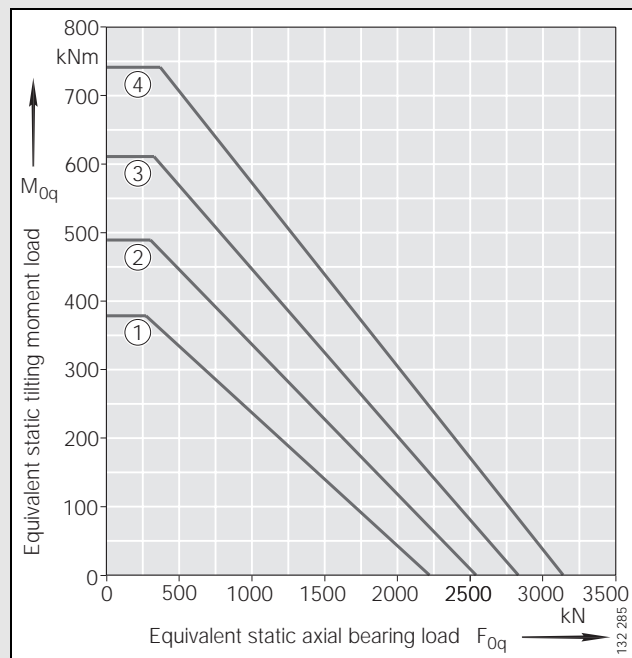

Static limiting load diagram
Raceway (supported load)

Four point contact bearings

Standard series 25
internal gear teeth

Series VSI

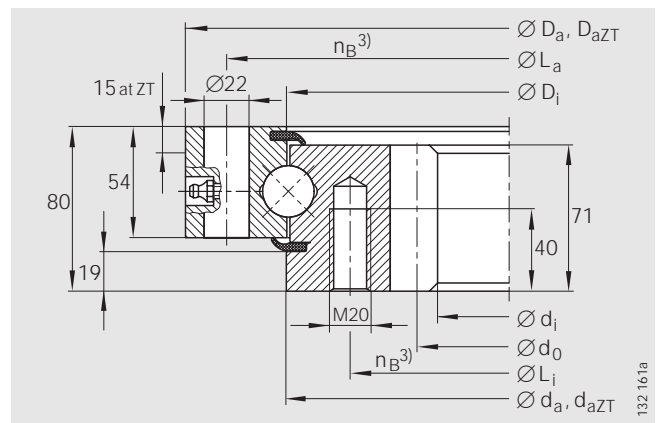

VSI 25

4 taper type lubrication nipples, DIN 71412-A M10×1, no. ① and ② arranged evenly about the circumference and recessed;

no. ③ and ④ ≈ arranged evenly about the circumference

Dimension table · Dimensions in mm

Designation	no. ¹⁾	Mass ≈kg	Dimensions						Fixing holes			Fixing screws $F_{r, perm}$ (friction locking) ⁴⁾ kN
			D_a	D_{aZT} ²⁾ -IT8	d_i	D_i	d_a	d_{aZT} ²⁾ -IT8	L_a	L_i	n_B ³⁾	
VSI 25 0755 N	①	119	855	853	610	753	757	755	815	694	24	290,4
VSI 25 0855 N	②	137	955	953	710	853	857	855	915	794	28	338,8
VSI 25 0955 N	③	149	1055	1053	810	953	957	955	1015	894	30	363,3
VSI 25 1055 N	④	165	1155	1153	910	1053	1057	1055	1115	994	30	363,3

¹⁾ Number of associated curve, see static limiting load diagram *Raceway* and *Fixing screws*.

²⁾ Bearing with centring (suffix ZT), for centring lengths see *dimension drawing*.

³⁾ Number of holes per ring.

⁴⁾ Maximum radial load. For load carrying capacity of screws see section *Fixing screws*, page 20.



Gear teeth			Tooth force		Basic load ratings				Internal clearance	
d ₀	m	z	F _{Z norm} kN	F _{Z max} kN	axial		radial		Radial clearance	Axial tilting clearance
					dyn. C _a kN	stat. C _{0a} kN	dyn. C _r kN	stat. C _{0r} kN		
630	10	63	68	98,9	460	2250	300	1010	0,03 incl. 0,13	0,05 incl. 0,24
730	10	73	68	98,9	485	2550	315	1150	0,03 incl. 0,13	0,05 incl. 0,24
830	10	83	68	98,9	500	2850	330	1280	0,03 incl. 0,13	0,05 incl. 0,24
930	10	93	68	98,9	520	3150	340	1410	0,03 incl. 0,13	0,05 incl. 0,24

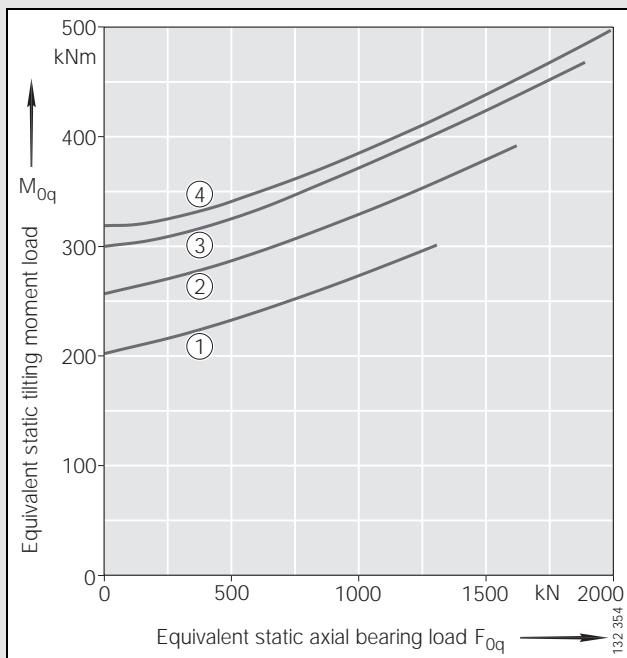

Static limiting load diagram
Fixing screws (supported load)

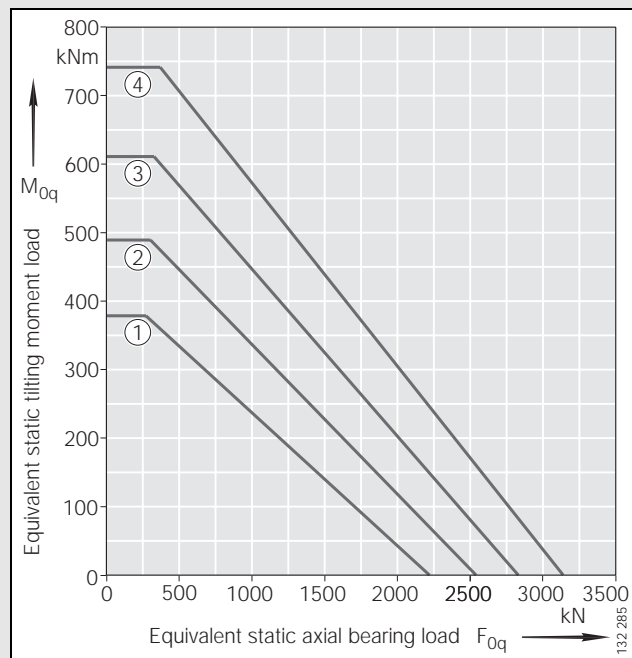

Static limiting load diagram
Raceway (supported load)

Four point contact bearings

Standard series 25
without gear teeth

Series VSU

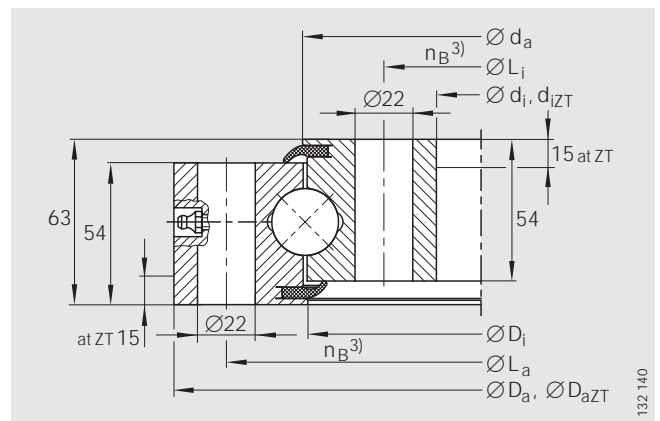

VSU 25

4 taper type lubrication nipples, DIN 71412-A M10×1,
no. ① and ② arranged evenly about the circumference
and recessed;

no. ③ and ④ ≈ arranged evenly about the circumference

Dimension table · Dimensions in mm

Designation	no. ¹⁾	Mass ≈kg	Dimensions					
			D _a	D _{aZT} ²⁾	d _i	d _{iZT} ²⁾	D _i	d _a
VSU 25 0755	①	90	855	853	655	657	753	757
VSU 25 0855	②	101	955	953	755	757	853	857
VSU 25 0955	③	115	1055	1053	855	857	953	957
VSU 25 1055	④	128	1155	1153	955	957	1053	1057

¹⁾ Number of associated curve,
see static limiting load diagram *Raceway and Fixing screws*.

²⁾ Bearing with centring (suffix ZT), for centring lengths see *dimension drawing*.

³⁾ Number of holes per ring.

⁴⁾ Maximum radial load. For load carrying capacity of screws see section *Fixing screws*, page 20.



Fixing holes			Fixing screws $F_{r\text{ perm}}$ (friction locking) ⁴⁾ kN	Basic load ratings				Internal clearance	
L_a	L_l	$n_B^{3)}$		axial		radial		Radial clearance	Axial tilting clearance
				dyn. C_a kN	stat. C_{0a} kN	dyn. C_r kN	stat. C_{0r} kN		
815	695	24	290,4	460	2 250	300	1010	0,03 incl. 0,13	0,05 incl. 0,24
915	795	28	338,8	485	2 550	315	1150	0,03 incl. 0,13	0,05 incl. 0,24
1015	895	30	363,3	500	2 850	330	1280	0,03 incl. 0,13	0,05 incl. 0,24
1115	995	30	363,3	520	3 150	340	1410	0,03 incl. 0,13	0,05 incl. 0,24

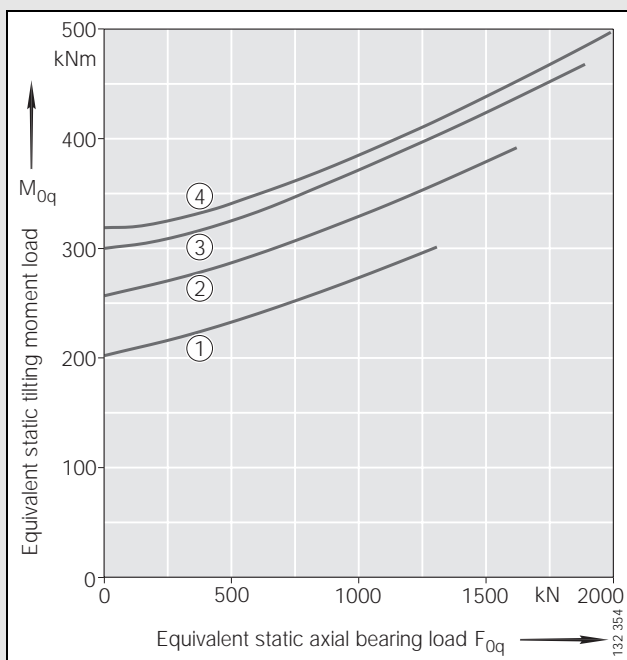

Static limiting load diagram
Fixing screws (supported load)

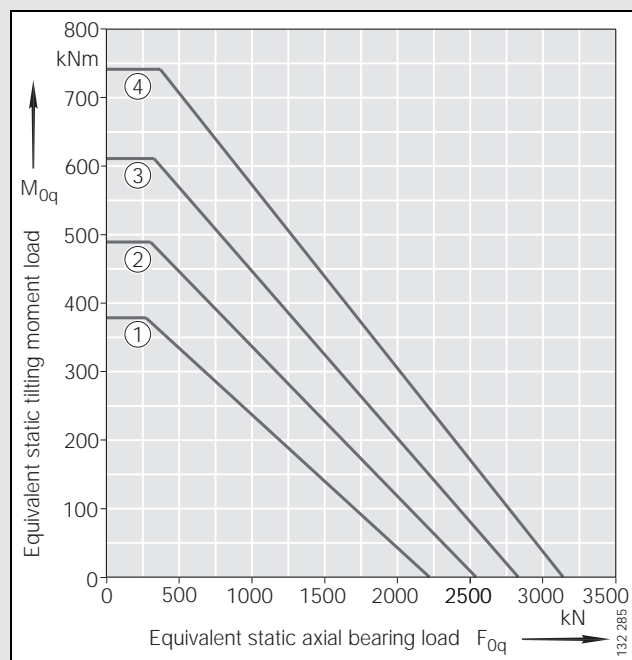

Static limiting load diagram
Raceway (supported load)

Four point contact bearings

external gear teeth

Series VA

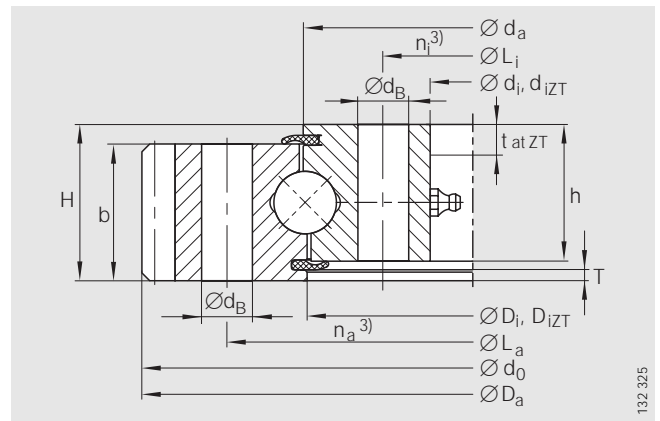

VA

No. ②, ④

4 taper type lubrication nipples, DIN 71412,
≈ arranged evenly about the circumference

132.325

Dimension table · Dimensions in mm

Designation	no. ¹⁾	Mass ≈ kg	Dimensions									
			Da	di	d _{iZT} ²⁾ +IT8	Di	D _{iZT} ²⁾ +IT8	da	H	h	T	t
VA 14 0188 V⁵⁾	①	7,5	259,36	135	–	189	–	187	35	30	–	–
VA 16 0235 N	②	13	318,6	171	173	234	236	236	40	35	2,3	6
VA 16 0302 N⁶⁾	③	14	384	238	–	–	–	302,3	32	30	–	–
VA 25 0309 N	④	29,5	408,4	235	237	308	310	310	60	52,5	3	8

1) Number of associated curve,
see static limiting load diagram *Raceway and Fixing screws*.

2) Bearing with centring (suffix ZT), centring lengths (T, t).
No. ①, ③ not available in design ZT.

3) Number of holes per ring.

4) Maximum radial load. For load carrying capacity of screws see section *Fixing screws*, page 20.

5) Gear teeth quenched and tempered.

6) No relubrication facility.

Radial clearance and axial tilting clearance

Designation	no.	Radial clearance	Axial tilting clearance
VA 14 0188 V	①	0,03 incl. 0,1	0,05 incl. 0,2
VA 16 0235 N	②	0,04 incl. 0,16	0,07 incl. 0,26
VA 16 0302 N	③	0,04 incl. 0,16	0,07 incl. 0,6
VA 25 0309 N	④	0,06 incl. 0,25	0,1 incl. 0,41

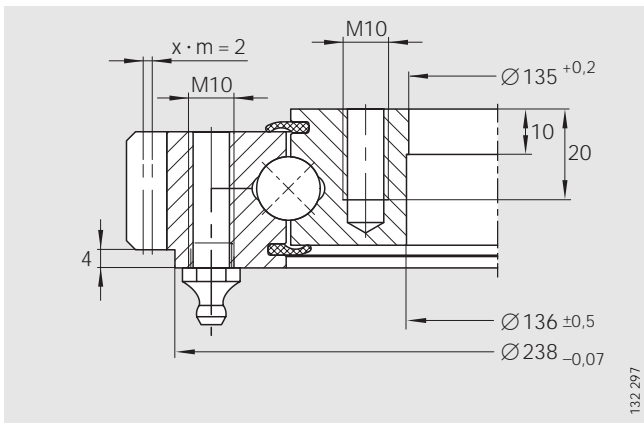

VA
No. ①
2 taper type lubrication nipples, DIN 71 412-A M10×1,
arranged evenly about the circumference

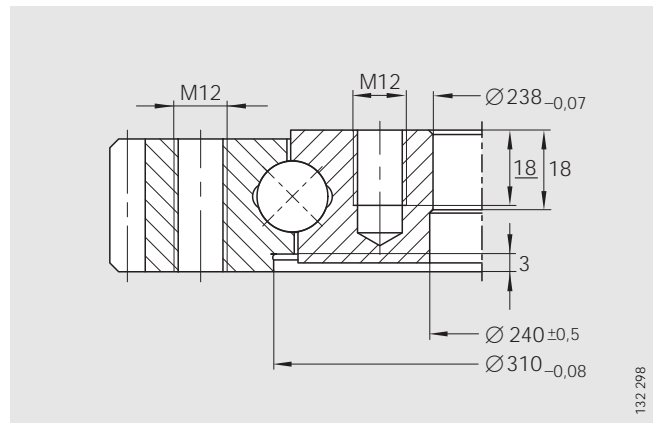

VA
No. ③

Fixing holes					Fixing screws $F_{r,perm}$ (friction locking) ⁴⁾ kN	Gear teeth				Tooth force		Basic load ratings			
L_a	L_i	$n_a^{3)}$	$n_i^{3)}$	d_B		d_0	m	z	b	$F_{z,norm}$ kN	$F_{z,max}$ kN	axial		radial	
												dyn. C_a kN	stat. C_{0a} kN	dyn. C_r kN	stat. C_{0r} kN
222	154	16	16	-	44,8	248	4	62	26	10,4	15,3	118	410	77	185
275	195	12	12	13	49,6	312	4	78	35	11	16,1	153	345	101	156
343	262	20	20	-	82,6	376	4	94	30	11	16,1	168	445	110	200
359	259	24	24	13	99,1	400	5	80	52,5	12,9	18,8	325	650	215	295

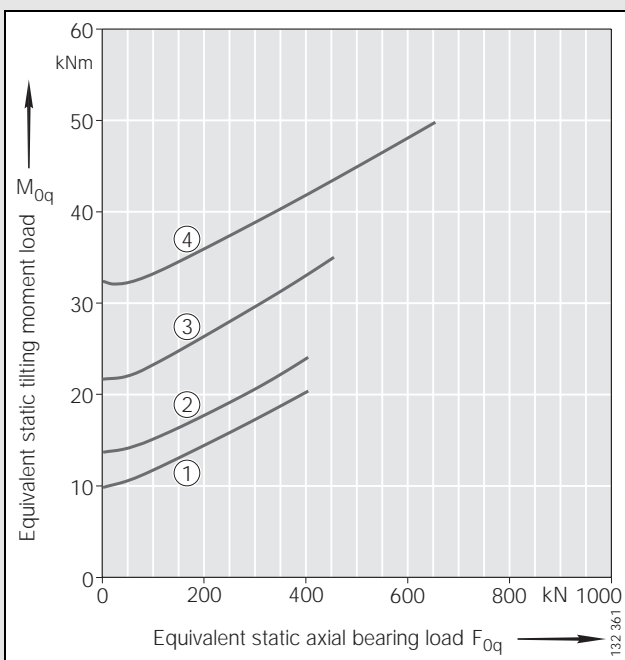

Static limiting load diagram
Fixing screws (supported load)

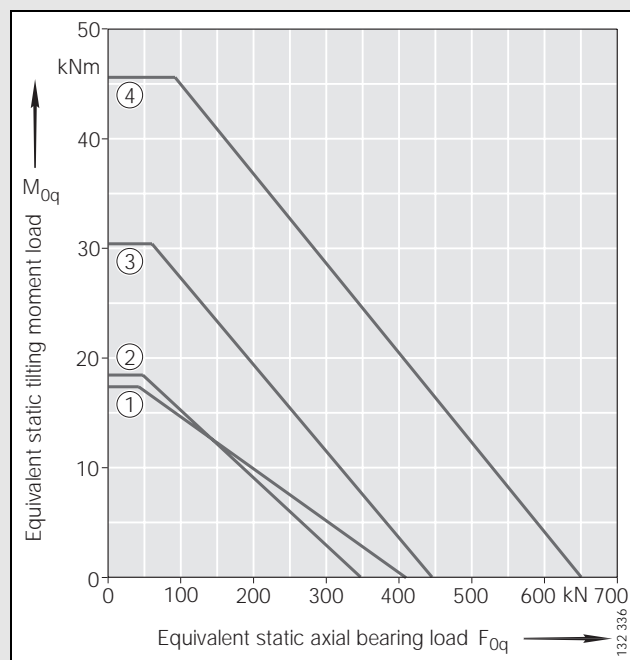

Static limiting load diagram
Raceway (supported load)

Four point contact bearings

internal gear teeth

Series VI

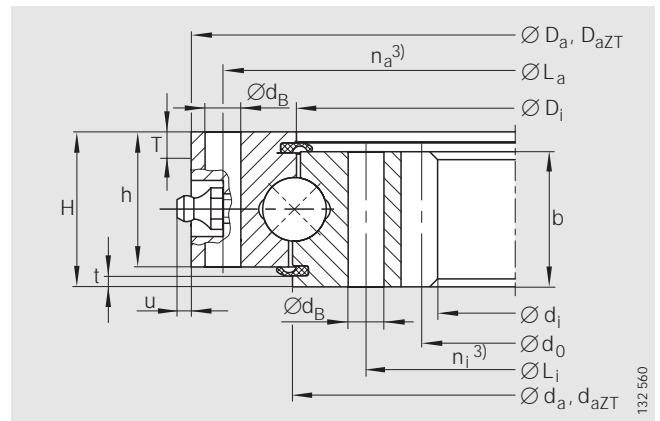

VI

No. ①

2 taper type lubrication nipples, DIN 71412-A M10×1, arranged evenly about the circumference and partially recessed

Dimension table · Dimensions in mm

Designation	no. ¹⁾	Mass ≈kg	Dimensions										
			D_a	$D_{aZT}^{2)}$	d_i	D_i	d_a	$d_{aZT}^{2)}$	H	h	T	t	u
VI 16 0288 N	①	12	340	338 -IT8	216	287	289	287 -IT8	39	34	6	2,5	9,5
VI 14 0326 V⁵⁾	②	18	382	-	250	333	320	-	59	-	-	-	-
VI 16 0420 N	③	23	486	484	332	419	421	419	39	34	6	2,5	-

1) Number of associated curve, see static limiting load diagram *Raceway and Fixing screws*.

2) Bearing with centring (suffix ZT), centring lengths (T, t). No. ② not available in design ZT.

3) Number of holes per ring.

4) Maximum radial load. For load carrying capacity of screws see section *Fixing screws*, page 20.

5) Without seals/gear teeth quenched and tempered.

Radial clearance and axial tilting clearance

Designation	no.	Radial clearance	Axial tilting clearance
VI 16 0288 N	①	0,04 incl. 0,16	0,07 incl. 0,26
VI 14 0326 V	②	0,03 incl. 0,08	0,08 incl. 0,18
VI 16 0420 N	③	0,04 incl. 0,16	0,07 incl. 0,26

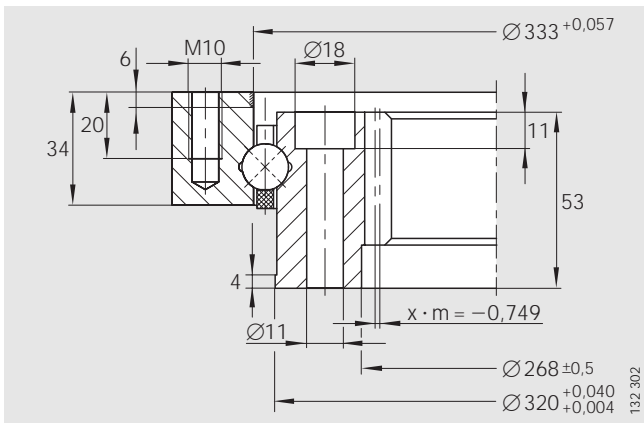

VI
No. ②

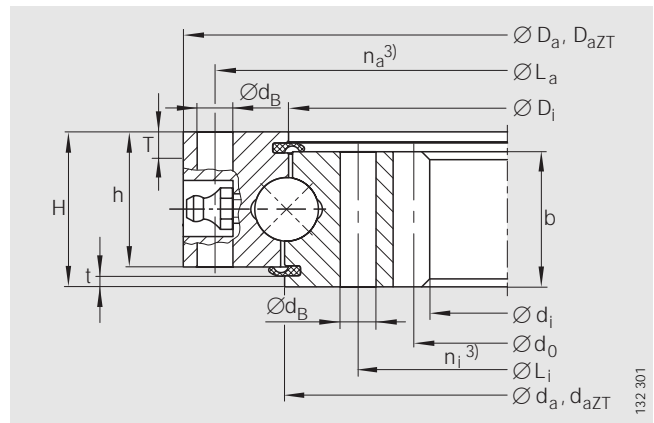

VI
No. ③
2 taper type lubrication nipples, DIN 71412-A M6,
arranged evenly about the circumference



Fixing holes					Fixing screws $F_{r,perm}$ (friction locking) ⁴⁾ kN	Gear teeth				Tooth force		Basic load ratings			
L_a	L_i	$n_a^{3)}$	$n_i^{3)}$	d_B		d_0	m	z	b	$F_{z, norm}$	$F_{z, max}$	axial		radial	
									kN	kN	dyn. C_a kN	stat. C_{0a} kN	dyn. C_r kN	stat. C_{0r} kN	
324	252	20	20	9	35	224	4	56	34	12,3	17,8	165	420	108	190
362	290	8	8	-	22,4	255,5	3,5	73	40	10,8	16,1	83	206	78	93
462	378	16	16	14	66,1	340	4	85	34	12,3	17,8	191	620	125	275

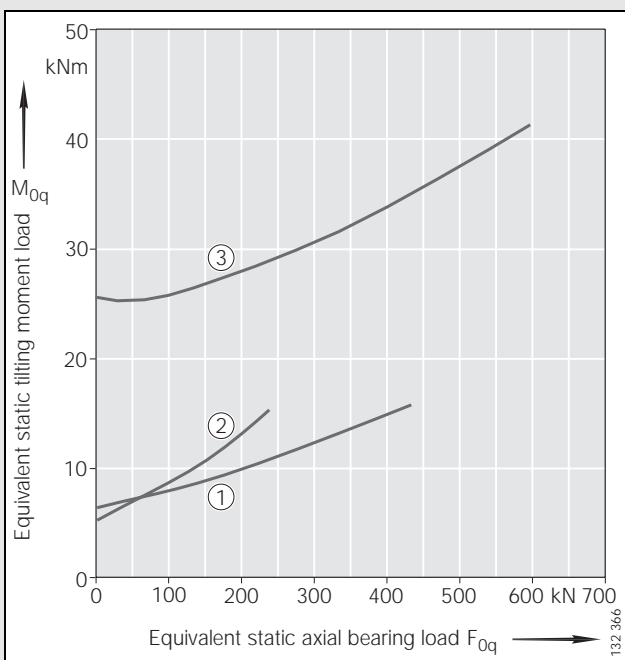

Static limiting load diagram
Fixing screws (supported load)

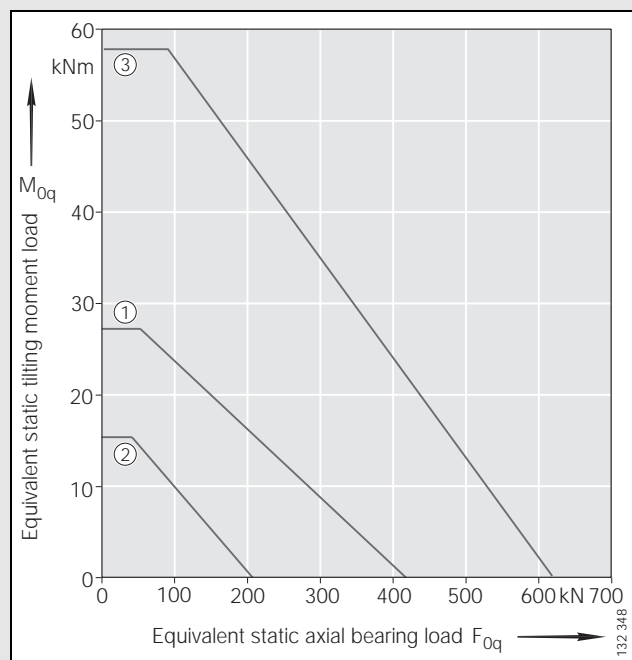

Static limiting load diagram
Raceway (supported load)

Four point contact bearings

without gear teeth

Series VU

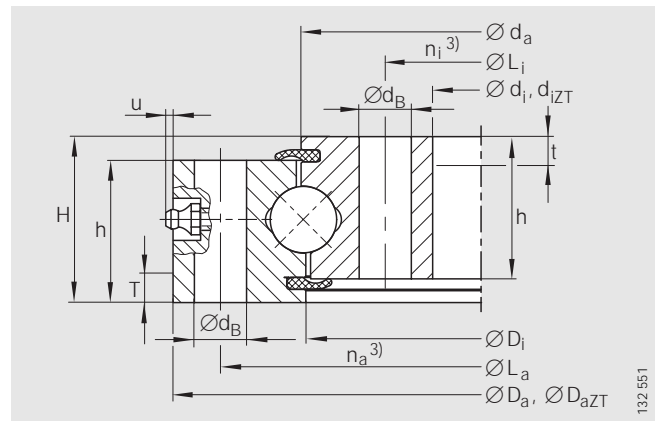

VU

No. ①, ④, ⑤

2 taper type lubrication nipples, DIN 71412, arranged evenly about the circumference and partially recessed

Dimension table · Dimensions in mm

Designation	no. ¹⁾	Mass ≈kg	Dimensions										
			Da	DaZT ²⁾ -IT8	di	diZT ²⁾ +IT8	Di	da	H	h	T	t	u max.
VU 14 0179	①	7	234	232	124,5	126,5	178	180	35	30	5	5	3
VU 20 0220	②	16	302	300	138	140	219	221	46	41	6	6	–
VU 13 0225⁵⁾	③	5,4	290	–	200	–	237,6	213	24	24	–	–	–
VU 20 0260	④	15	329	327	191	193	259	261	46	41	7	7	2
VU 14 0325	⑤	12	380	378	270	272	324	326	35	30	5	5	3
VU 25 0380	⑥	44	485	483	275	277	379	381	55	50	8	8	–

¹⁾ Number of associated curve, see static limiting load diagram *Raceway and Fixing screws*.

²⁾ Bearing with centring (suffix ZT), centring lengths (T, t). No. ③ not available in design ZT.

³⁾ Number of holes per ring.

⁴⁾ Maximum radial load. For load carrying capacity of screws see section *Fixing screws*, page 20.

⁵⁾ Inner ring through hardened.

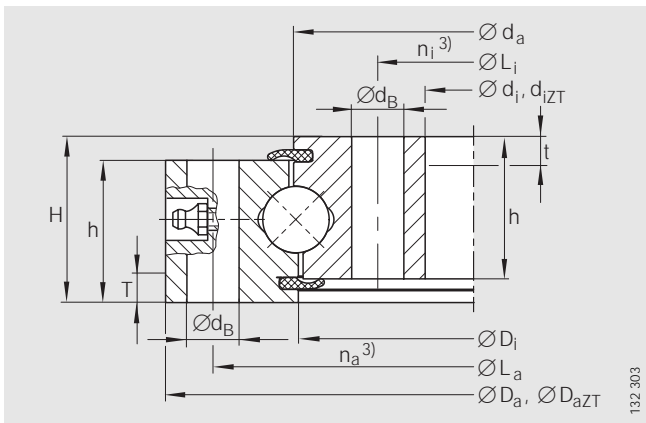

132 303

VU
No. ②, ⑥
2 taper type lubrication nipples, DIN 71 412-A M10×1,
arranged evenly about the circumference and recessed

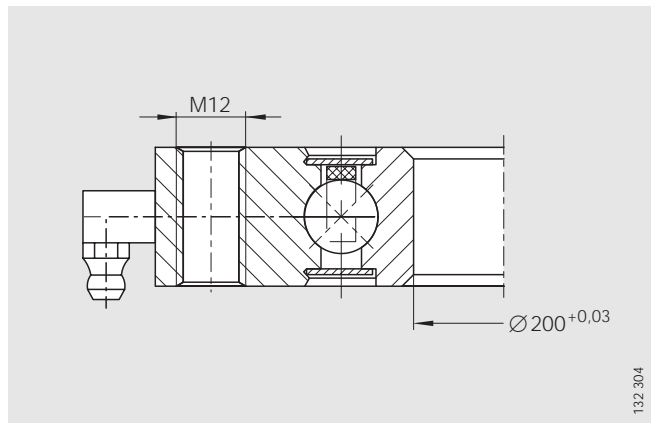

132 304

VU
No. ③
3 taper type lubrication nipples, DIN 71 412-C M8×1,
arranged evenly about the circumference



Fixing holes					Fixing screws	Basic load ratings				Internal clearance	
L _a	L _i	n _a ³⁾	n _i ³⁾	d _B	F _{r perm} (friction locking) ⁴⁾ kN	axial		radial		Radial clearance	Axial tilting clearance
						dyn. C _a kN	stat. C _{0a} kN	dyn. C _r kN	stat. C _{0r} kN		
214	144,5	12	12	11	33,6	115	255	75	114	0,04 incl. 0,14	0,07 incl. 0,23
270	170	10	10	18	78	201	435	132	197	0,05 incl. 0,2	0,08 incl. 0,33
270	-	6	-	-	19,8	49	87	46	39,5	0,02 incl. 0,06	0,05 incl. 0,16
305	215	20	20	14	82,6	217	520	143	233	0,05 incl. 0,2	0,08 incl. 0,33
360	290	24	24	11	67,2	146	460	95	208	0,04 incl. 0,14	0,07 incl. 0,23
453	307	16	16	18	124,8	350	800	230	360	0,06 incl. 0,25	0,11 incl. 0,41

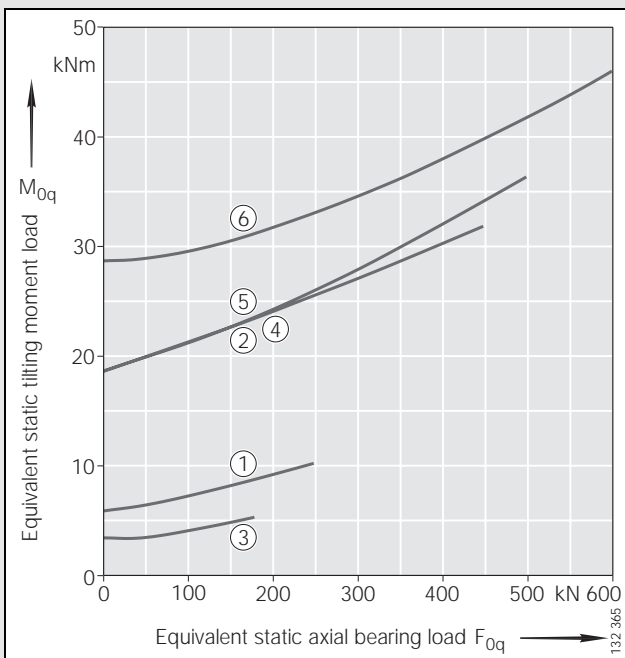

Static limiting load diagram
Fixing screws (supported load)

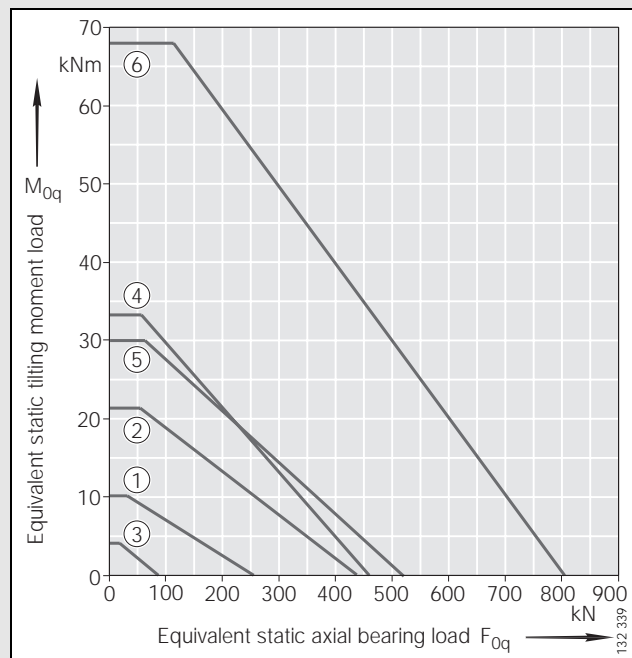

Static limiting load diagram
Raceway (supported load)

Four point contact bearings

without gear teeth

Series VU

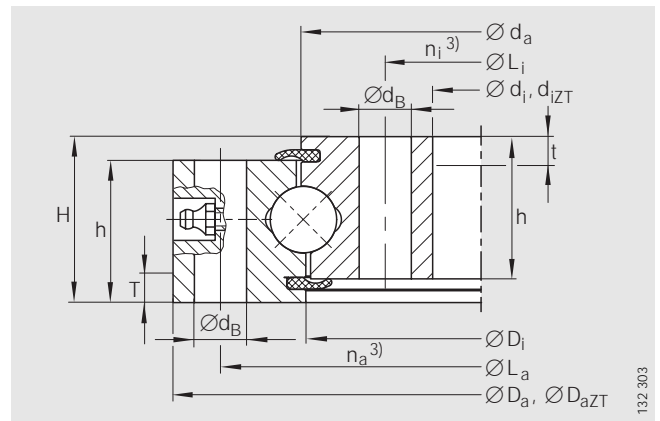

VU
 No. ⑦ to ⑩
 Taper type lubrication nipples, DIN 71 412,
 ≈ arranged evenly about the circumference

Dimension table (continued) · Dimensions in mm

Designation	no. ¹⁾	Mass ≈kg	Dimensions									
			D_a	D_{aZT} ²⁾	d_i	d_{iZT} ²⁾	D_i	d_a	H	h	T	t
VU 20 0405	⑦	25	474	472	336	338	404	406	46	41	7	7
VU 25 0433	⑧	41	522	520	344	346	432	434	55	50	8	8
VU 30 0574	⑨	82	680	678	468	470	572	576	68	61	10	10
VU 36 0680	⑩	120	795	793	565	567	678	682	79	72	11	11

¹⁾ Number of associated curve, see static limiting load diagram *Raceway* and *Fixing screws*.

²⁾ Bearing with centring (suffix ZT), centring lengths (T, t).

³⁾ Number of holes per ring.

⁴⁾ Maximum radial load. For load carrying capacity of screws see section *Fixing screws*, page 20.



Fixing holes					Fixing screws $F_{r\text{ perm}}$ (friction locking) ⁴⁾ kN	Basic load ratings				Internal clearance	
L_a	L_i	$n_a^{3)}$	$n_l^{3)}$	d_B		axial		radial		Radial clearance	Axial tilting clearance
						dyn. C_a kN	stat. C_{0a} kN	dyn. C_r kN	stat. C_{0r} kN		
450	360	30	30	14	123,9	260	810	169	360	0,05 incl. 0,2	0,08 incl. 0,33
490	376	20	20	18	156	370	910	243	410	0,06 incl. 0,25	0,11 incl. 0,41
640	508	20	20	22	242	495	1540	325	690	0,08 incl. 0,3	0,13 incl. 0,49
755	605	30	30	22	363	640	2260	415	1020	0,09 incl. 0,36	0,15 incl. 0,59

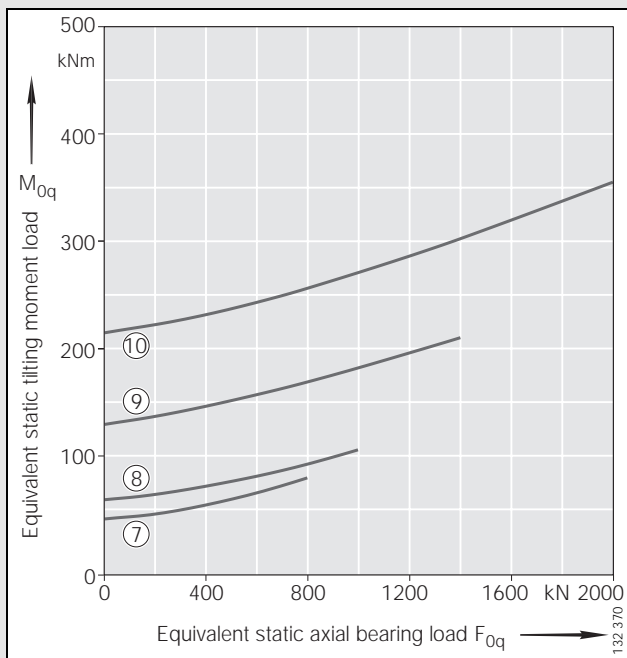

Static limiting load diagram
Fixing screws (supported load)

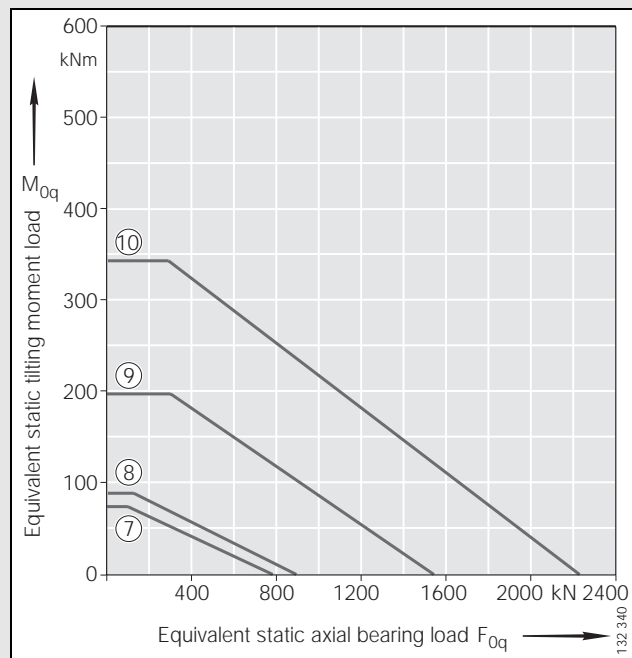

Static limiting load diagram
Raceway (supported load)

Crossed roller bearings

with external gear teeth, with internal gear teeth,
without gear teeth



Features

Crossed roller bearings

- are units comprising inner and outer rings with a closing plug and securing dowel, rolling elements, spacers, contact seals and lubrication nipples
 - gear teeth on the outer ring, inner ring or without gear teeth
 - bearing rings with through holes or threaded holes for fixing screws
- are suitable for circumferential speeds up to 2 m/s ($n \cdot D_M = 38\,200$), for short periods up to 2,6 m/s ($n \cdot D_M = 49\,700$)
- can support high radial loads, moderate axial loads and tilting moment loads
 - can support higher dynamic loads than four point contact bearings
- are suitable for supported and suspended loads
- are preloaded
- are used
 - where zero operating clearance or preload is required
 - if the rotational resistance must be particularly uniform
 - where there are high requirements for accuracy and rigidity of the bearing arrangement
- have contact seals on both sides that protect the raceway system against dust, contamination and moisture
- are greased with a lithium complex soap grease KP2N-20 according to DIN 51 825, but can also be lubricated with oil
- are suitable for operating temperatures from -25 °C to $+80\text{ °C}$
- are very easy to fit since the bearing rings are screw mounted directly to the adjacent construction
- are also available in series **XA**, **XI**, **XU**.

Crossed roller bearings



XSA 14

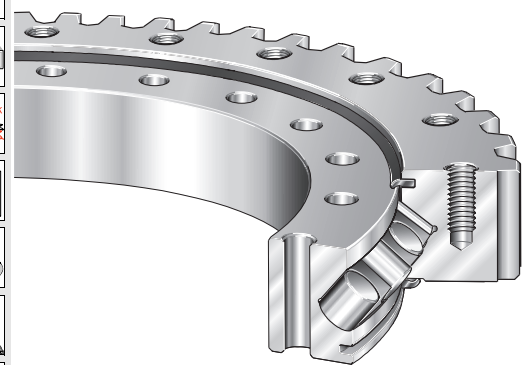

132 394a



82

- standard series 14, external gear teeth
- cylindrical rollers to DIN 5402, spacers made from plastic
- lubrication nipple on the circumference of the ring without gear teeth
- rolling element pitch circle diameter from 414 mm to 1094 mm



XA

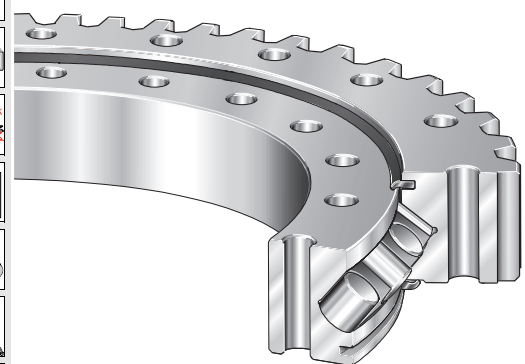

132 402a



88

- crossed roller bearing, external gear teeth
- cylindrical rollers to DIN 5402, spacers made from plastic
- lubrication nipple on the circumference of the ring without gear teeth
- rolling element pitch circle diameter 235 mm and 352 mm

XSI 14

132 3955a

- standard series 14, internal gear teeth
- cylindrical rollers to DIN 5402, spacers made from plastic
- lubrication nipple on the circumference of the ring without gear teeth
- rolling element pitch circle diameter from 414 mm to 1094 mm

84

XSU 14

132 396a

- standard series 14 without gear teeth
- cylindrical rollers to DIN 5402, spacers made from plastic
- lubrication nipple on the circumference of the outer ring
- rolling element pitch circle diameter from 414 mm to 1094 mm

86

XI

132 404a

- crossed roller bearing, internal gear teeth
- cylindrical rollers to DIN 5402, spacers made from plastic
- lubrication nipple on the circumference of the ring without gear teeth
- rolling element pitch circle diameter 288 mm

88

XU

132 396a

- crossed roller bearing without gear teeth
- cylindrical rollers to DIN 5402, spacers made from plastic
- lubrication nipple on the circumference of the outer ring
- rolling element pitch circle diameter from 77 mm to 515 mm

90

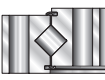

Crossed roller bearings

with external gear teeth, with internal gear teeth,
without gear teeth



Accuracy

The following tables give tolerances for slewing rings
(for further tolerances, see the *dimension tables*).

Diameter tolerances

Table 1 · Outside and inside diameter tolerances in accordance with ISO 2 768-m

Outside and inside diameter D_a, d_i mm	Tolerance according to ISO 2 768-m mm
incl. 120	$\pm 0,3$
over 120 incl. 400	$\pm 0,5$
over 400 incl. 1000	$\pm 0,8$
over 1000	$\pm 1,2$

Table 2 · Tolerances for gap diameter¹⁾

Rolling element diameter (roller) mm	Tolerance for gap diameter $D_i (+), d_a (-)$ mm
5 to 6	0,3
8 to 12	0,4
14 to 16	0,5
18 to 20	0,6
22 to 26	1
28 to 30	1,5

¹⁾ Values for XS 14: see *dimension tables*.

Table 3 · Tolerances for hole pitch circle diameter

Hole pitch circle diameter L_a, L_i mm	Positional tolerance for fixing holes \oplus mm
incl. 500	$\pm 0,5$
over 500 incl. 1200	$\pm 0,6$

Diameter tolerances for fixing holes in accordance
with ISO 273, "medium".

Height tolerances

Table 4 · Mounting height (H) and individual ring height (h)

Mounting height H		Individual ring height h	
Series	Height tolerance mm	Series	Height tolerance mm
XS 14	$\pm 0,3$	XS 14	$\pm 0,3$
X	In accordance with quotation and delivery drawing	X	In accordance with quotation and delivery drawing

Centring devices

Table 5 · ISO tolerance series

Centring diameter mm	IT8	IT7
	Outside diameter (-) Inside diameter (+) mm	
over 120 incl. 180	0,06	0,04
over 180 incl. 250	0,07	0,05
over 250 incl. 315	0,08	0,05
over 315 incl. 400	0,09	0,06
over 400 incl. 500	0,1	0,06
over 500 incl. 630	0,11	0,07
over 630 incl. 800	0,13	0,08
over 800 incl. 1000	0,14	0,09
over 1000 incl. 1250	0,17	0,11

Surface quality

Table 6 · Surface quality

Machined surfaces	Mean roughness depth R_z μm
Outside surfaces and holes	100
Centring devices and seal running surfaces	25
Gear teeth, grade 12	100
Gear teeth, grade 10	25

Gear teeth tolerances

Table 7 · Tolerances of tip pitch circle diameter for gear teeth

Tip pitch circle diameter D_a, d_i mm	Tolerance External gear teeth D_a (-) Internal gear teeth d_i (+) mm
incl. 500	0,4
over 500 incl. 1200	0,7

Tolerances for fixing holes (Figure 1)

Table 8 · Tolerances for fixing holes

Thread	d_B	d_s	t_s		Thread runout	
			Type K, for screws to DIN 912	Type J, for screws to DIN 6912	Rule	short
M 6	6,6 +0,25	11+0,25	6,8 +0,4	4,8 +0,4	5,1	3,2
M 8	9 +0,25	15+0,25	9 +0,4	6 +0,4	6,2	3,9
M10	11 +0,25	18+0,25	11 +0,4	7,5 +0,4	7,3	4,6
M12	(13,5) ¹ +0,25	20+0,3	13 +0,4	8,5 +0,4	8,3	5,2
	14 +0,25	20+0,3	13 +0,4	8,5 +0,4	8,3	5,2
M14	(15,5) ¹ +0,25	24+0,3	15 +0,4	9,5 +0,4	9,3	5,8
	16 +0,25	24+0,3	15 +0,4	9,5 +0,4	9,3	5,8
M16	(17,5) ¹ +0,25	26+0,25	17,5 +0,4	11,5 +0,4	9,3	5,8
	18 +0,25	26+0,25	17,5 +0,4	11,5 +0,4	9,3	5,8
M18	20 +0,3	30+0,3	19,5 +0,4	12,5 +0,4	11,2	7
M20	22 +0,3	33+0,4	21,5 +0,4	13,5 +0,4	11,2	7
M24	26 +0,3	40+0,4	25,5 +0,4	15,5 +0,4	13	8,2

¹⁾ The value (d_B) is valid for a hole with counterbore and drilled out for a thread.

Table 9 · Permissible runout error for gear teeth (N)¹⁾ in accordance with DIN 3962

Series	Position ²⁾	Runout of gear teeth ³⁾ mm
XSA 14	①	0,11
	②, ③, ④	0,125
	⑤	0,14
	⑥, ⑦	0,16
XSI 14	①, ②, ③	0,11
	④	0,125
	⑤, ⑥, ⑦	0,14
XA	①, ②	0,22
XI	①	0,2

¹⁾ (N) indicates normalised gear teeth.

²⁾ For the associated bearing, see the corresponding *dimension table*.

³⁾ In contrast to DIN 3962, the runout of the gear teeth is defined as the wall thickness variation between the rolling element pitch circle diameter and the pitch circle diameter of the gear teeth.

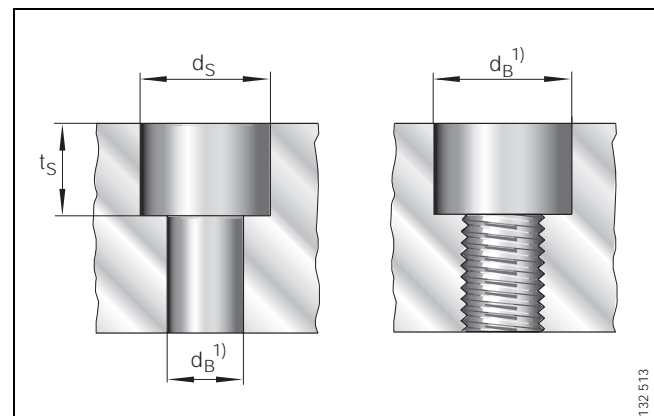
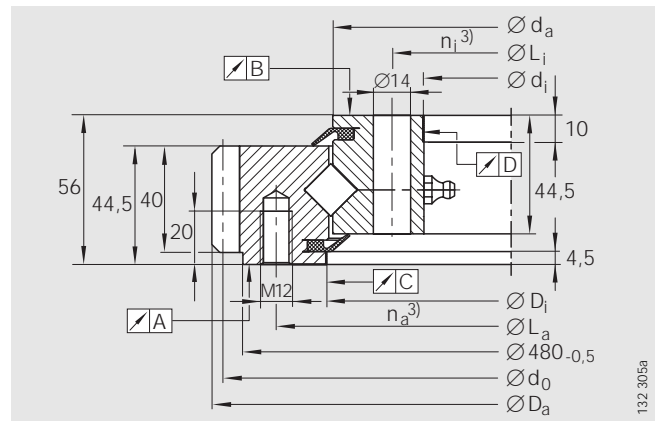

Figure 1 · Tolerances for fixing holes

Crossed roller bearings

Standard series 14
external gear teeth

Series XSA



XSA 14 0414 N

No. ①

4 taper type lubrication nipples, DIN 71 412-A M8×1,
arranged evenly about the circumference

132_305a

Dimension table · Dimensions in mm

Designation	No. ¹⁾	Mass ≈kg	Dimensions				Fixing holes			
			Da	di ²⁾ +IT7	Di ²⁾ +IT7	da	La	na ³⁾	Li	ni ³⁾
XSA 14 0414 N	①	32	503,3	344	417	413 _{-0,5}	455	20	368	24
XSA 14 0544 N	②	44	640,3	474	547	543 _{-0,5}	585	28	498	32
XSA 14 0644 N	③	52	742,3	574	647	643 _{-0,6}	685	32	598	36
XSA 14 0744 N	④	59	838,1	674	747	743 _{-0,6}	785	36	698	40
XSA 14 0844 N	⑤	71	950,1	774	847	843 _{-0,6}	885	36	798	40
XSA 14 0944 N	⑥	77	1046,1	874	947	943 _{-0,7}	985	40	898	44
XSA 14 1094 N	⑦	91	1198,1	1024	1097	1093 _{-0,7}	1135	44	1048	48

1) Number of associated curve,
see static limiting load diagram *Raceway and Fixing screws*.

2) Bearings always with centring, for centring lengths see *dimension drawing*.

3) Number of holes per ring.

4) Maximum radial load. For load carrying capacity of screws see section *Fixing screws*, page 20.

Running accuracy (to raceway)

Designation	No.	A	B	C	D
XSA 14 0414 N	①	0,04	0,04	0,06	0,06
XSA 14 0544 N	②	0,04	0,04	0,07	0,06
XSA 14 0644 N	③	0,05	0,05	0,08	0,07
XSA 14 0744 N	④	0,05	0,05	0,08	0,08
XSA 14 0844 N	⑤	0,05	0,05	0,09	0,08
XSA 14 0944 N	⑥	0,06	0,06	0,09	0,09
XSA 14 1094 N	⑦	0,07	0,07	0,11	0,11

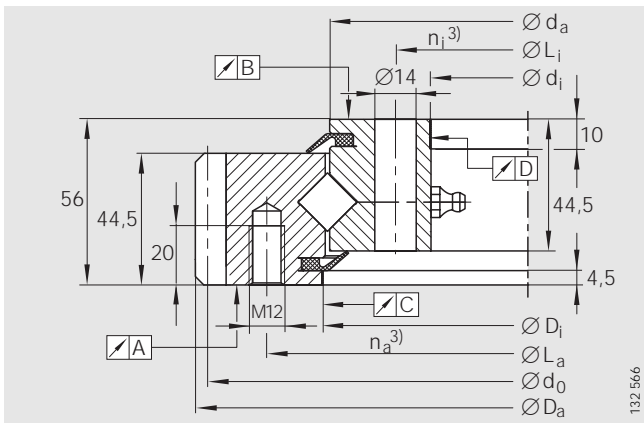

XSA 14
 No. ② to ⑦
 4 taper type lubrication nipples, DIN 71412-A M8×1,
 arranged evenly about the circumference

Fixing screws $F_{r \text{ perm}}$ (friction locking) ⁴⁾ kN	Gear teeth			Tooth force		Basic load ratings				Internal clearance Preload
	d_0	m	z	$F_{z \text{ norm}}$	$F_{z \text{ max}}$	axial		radial		
						dyn. C_a kN	stat. C_{0a} kN	dyn. C_r kN	stat. C_{0r} kN	
82,6	495	5	99	15,9	23,6	229	520	146	250	0,01 incl. 0,03
115,6	630	6	105	21,3	31,5	270	680	170	330	0,01 incl. 0,03
132,2	732	6	122	21,3	31,5	290	800	185	395	0,01 incl. 0,04
148,7	828	6	138	21,3	31,5	315	930	200	455	0,01 incl. 0,04
148,7	936	8	117	28,3	42	340	1050	215	510	0,01 incl. 0,04
165,2	1032	8	129	28,3	42	360	1170	227	580	0,01 incl. 0,05
181,7	1184	8	148	28,3	42	390	1360	246	670	0,01 incl. 0,05

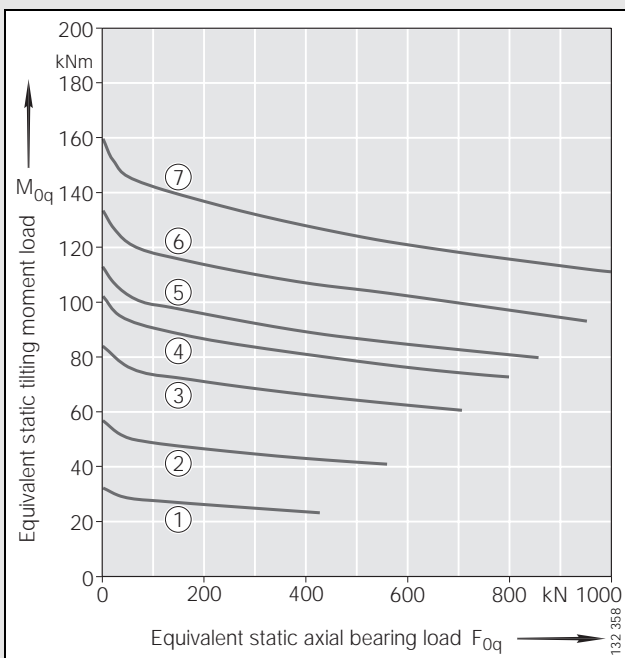

Static limiting load diagram
 Fixing screws (supported load)

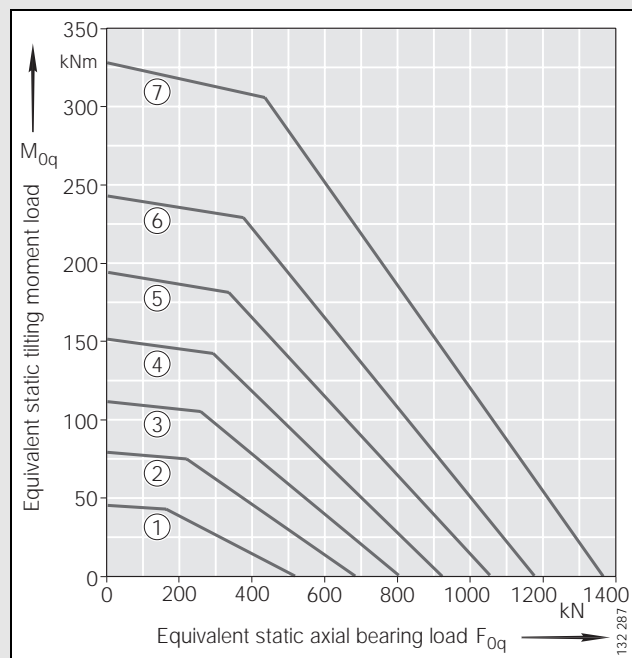

Static limiting load diagram
 Raceway (supported load)

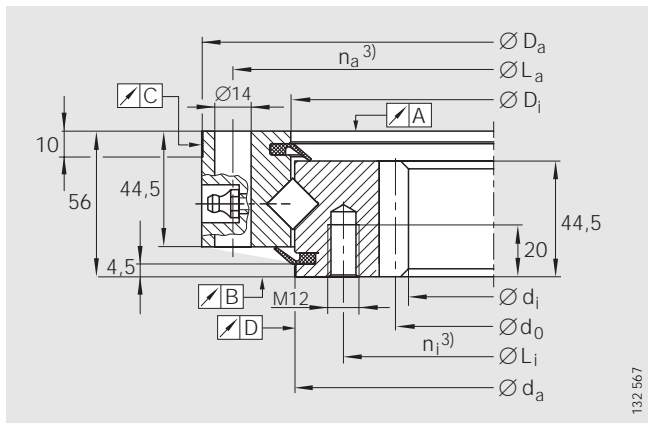

XSI 14
 No. ② to ⑦
 4 taper type lubrication nipples, DIN 71 412-A M8×1,
 arranged evenly about the circumference

Fixing screws $F_{r \text{ perm}}$ (friction locking) ⁴⁾ kN	Gear teeth			Tooth force		Basic load ratings				Internal clearance Preload
	d_0	m	z	$F_{z \text{ norm}}$ kN	$F_{z \text{ max}}$ kN	axial		radial		
						dyn. C_a kN	stat. C_{0a} kN	dyn. C_r kN	stat. C_{0r} kN	
99,1	335	5	67	17,7	26,2	229	520	146	250	0,01 incl. 0,03
132,2	456	6	76	23,7	35	270	680	170	330	0,01 incl. 0,03
148,7	558	6	93	23,7	35	290	800	185	395	0,01 incl. 0,04
165,2	660	6	110	23,7	35	315	930	200	455	0,01 incl. 0,04
165,2	752	8	94	31,4	46,7	340	1050	215	510	0,01 incl. 0,04
181,7	856	8	107	31,4	46,7	360	1170	227	580	0,01 incl. 0,05
198,2	1000	8	125	31,4	46,7	390	1360	246	670	0,01 incl. 0,05

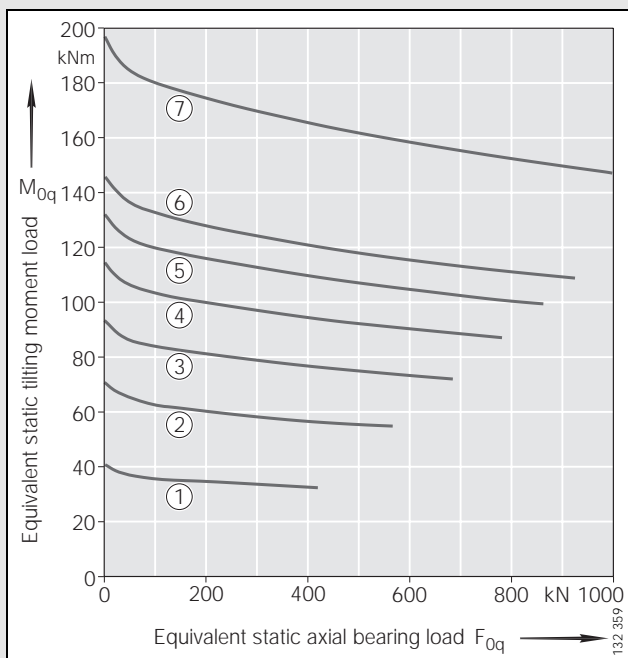

Static limiting load diagram
 Fixing screws (supported load)

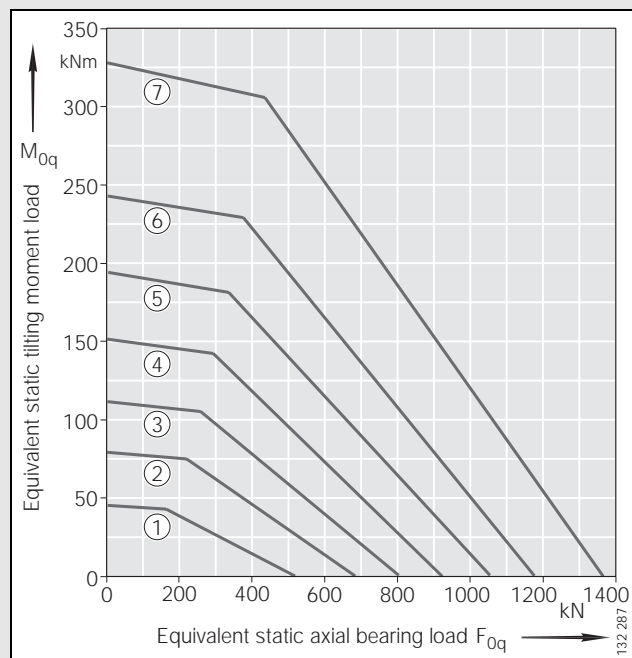

Static limiting load diagram
 Raceway (supported load)

L _i	n _i ³⁾	Fixing screws F _{r perm} (friction locking) ⁴⁾ kN	Basic load ratings				Internal clearance Preload
			axial		radial		
			dyn. C _a kN	stat. C _{0a} kN	dyn. C _r kN	stat. C _{0r} kN	
368	24	99,1	229	520	146	250	0,01 incl. 0,03
498	32	132,2	270	680	170	330	0,01 incl. 0,03
598	36	148,7	290	800	185	395	0,01 incl. 0,04
698	40	165,2	315	930	200	455	0,01 incl. 0,04
798	40	165,2	340	1050	215	510	0,01 incl. 0,04
898	44	181,7	360	1170	227	580	0,01 incl. 0,05
1048	48	198,2	390	1360	246	670	0,01 incl. 0,05

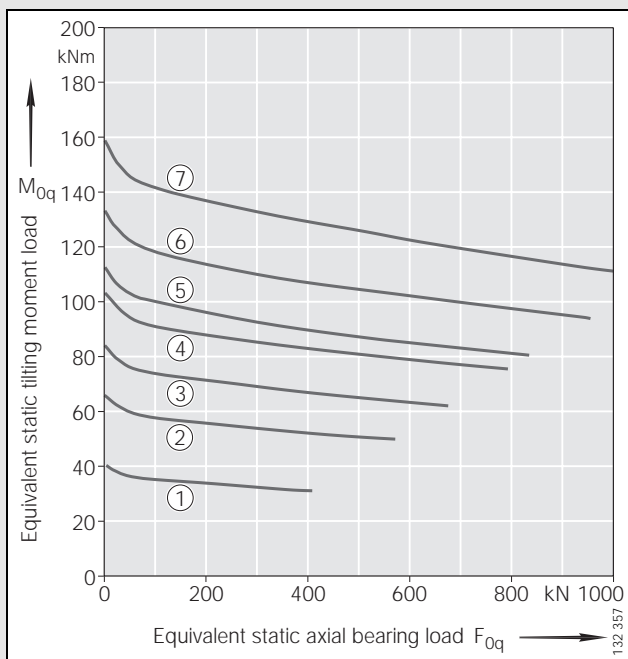

Static limiting load diagram
Fixing screws (supported load)

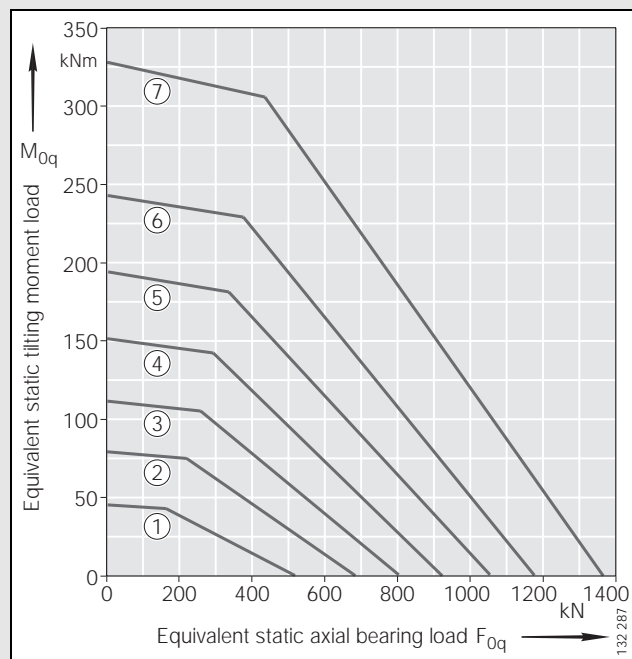

Static limiting load diagram
Raceway (supported load)

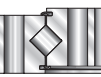

Crossed roller bearings

external gear teeth

Series XA

Crossed roller bearings

internal gear teeth

Series XI

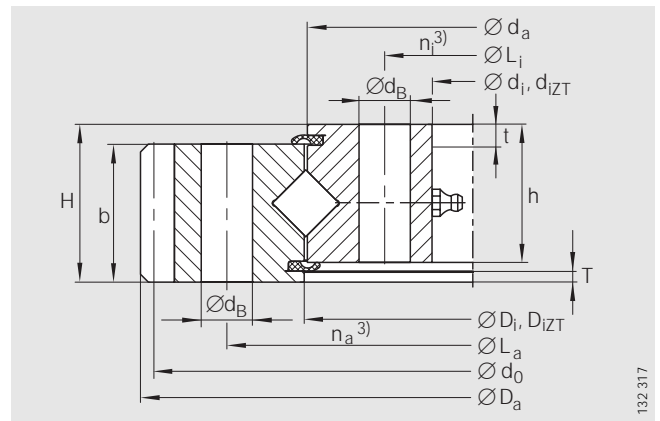

XA
No. ①
2 taper type lubrication nipples, DIN 71412-A M10×1,
arranged evenly about the circumference

Dimension table - Dimensions in mm

Designation	No. ¹⁾	Mass ≈kg	Dimensions										Fixing holes	
			Da	di	d _{IZT} ²⁾ +IT8	Di	D _{IZT} ²⁾ +IT8	da	H	h	T	t	La	Li
XA 12 0235 N	①	13,3	318,8	171	173	236±0,2	238	234±0,2	40	35	2,6	6	275	195
XA 20 0352 H⁵⁾	② ³⁾	34,5	462	274	-	353	-	351	59	54	-	-	407	298

1) Number of associated curve,
see static limiting load diagram *Raceway and Fixing screws*.

2) Bearing with centring (suffix ZT), centring lengths (T, t). No. ② not available in design ZT.

Dimension table - Dimensions in mm

Designation	No. ¹⁾	Mass ≈kg	Dimensions										Fixing holes		
			Da	D _{aZT} ²⁾ -IT8	di	Di	da	d _{aZT} ²⁾ -IT8	H	h	T	t	u	La	Li
XI 12 0288 N	③	12	340	338	216	289	287	285	38	33	5	2,5	6	324	252

1) Number of associated curve,
see static limiting load diagram *Raceway and Fixing screws*.

2) Bearing with centring (suffix ZT), centring lengths (T, t).

3) Number of holes per ring.

4) Maximum radial load. For load carrying capacity of screws see section *Fixing screws*, page 20.

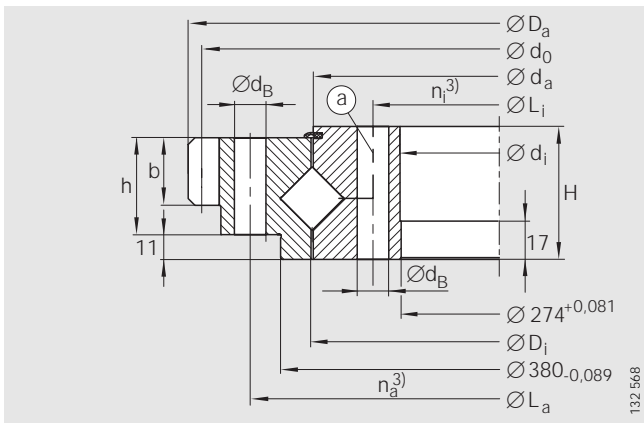

XA
No. ②
③ 1 lubrication hole M12×1, 10 mm deep

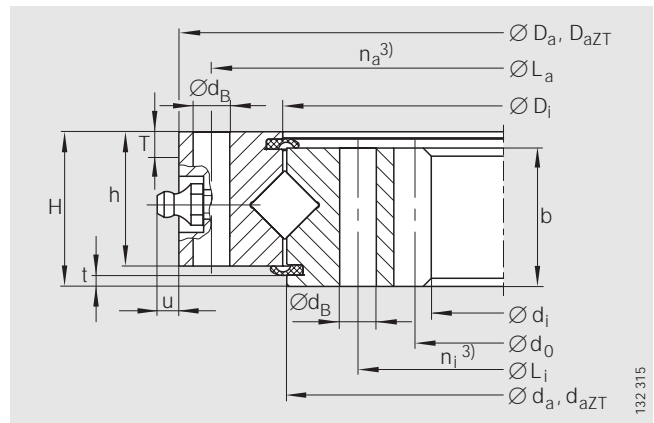

XI
No. ③
taper type lubrication nipples, DIN 71 412,
≈ arranged evenly about the circumference and partially recessed

$n_a^{3)}$	$n_i^{3)}$	d_B	Fixing screws $F_{r \text{ perm}}$ (friction locking) ⁴⁾ kN	Gear teeth				Tooth force		Basic load ratings				Internal clearance Preload
				d_o	m	z	b	$F_{z \text{ norm}}$ kN	$F_{z \text{ max}}$ kN	axial		radial		
										dyn. C_a kN	stat. C_{0a} kN	dyn. C_r kN	stat. C_{0r} kN	
12	12	13	49,6	312	4	78	35	11	16,1	135	235	86	115	0 incl. 0,02
24	24	14	99,1	450	6	75	30	20,9	34,5	335	720	214	355	0 incl. 0,02

3) Number of holes per ring.

4) Maximum radial load. For load carrying capacity of screws see section *Fixing screws*, page 20.

5) Gear teeth hardened.

$n_a^{3)}$	$n_i^{3)}$	d_B	Fixing screws $F_{r \text{ perm}}$ (friction locking) ⁴⁾ kN	Gear teeth				Tooth force		Basic load ratings				Internal clearance Preload
				d_o	m	z	b	$F_{z \text{ norm}}$ kN	$F_{z \text{ max}}$ kN	axial		radial		
										dyn. C_a kN	stat. C_{0a} kN	dyn. C_r kN	stat. C_{0r} kN	
20	20	9	35	224	4	56	34	12,3	17,8	150	290	95	141	0 incl. 0,02

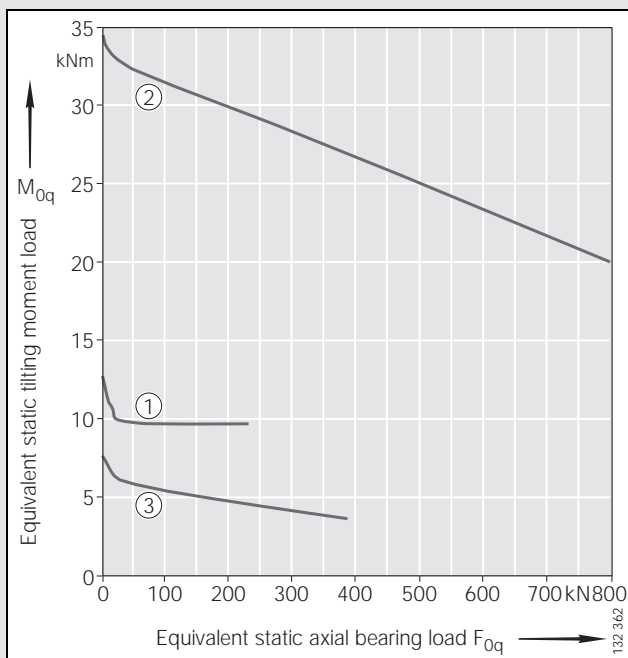

Static limiting load diagram
Fixing screws (supported load)

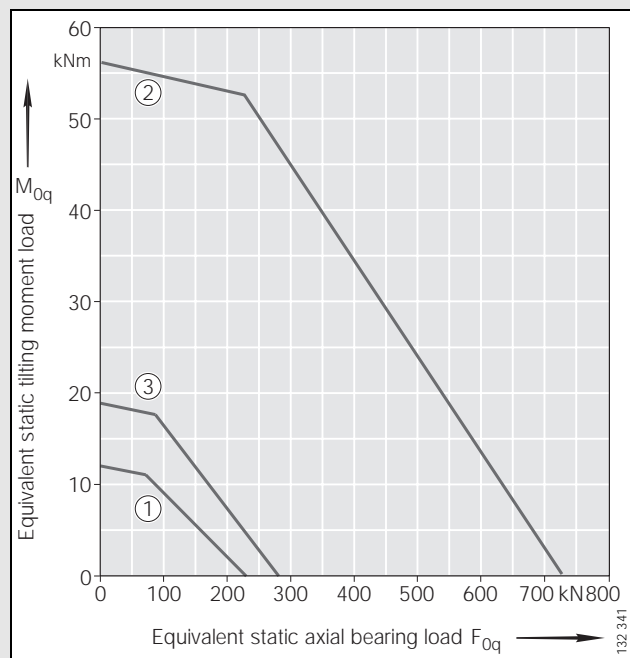

Static limiting load diagram
Raceway (supported load)

Crossed roller bearings

without gear teeth

Series XU

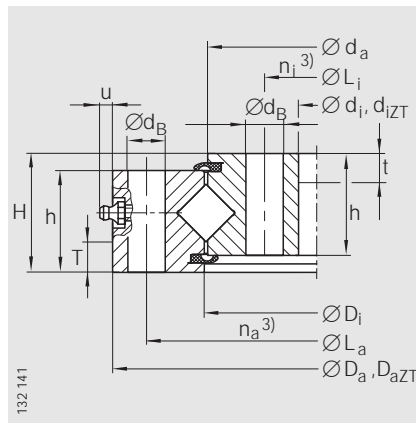

XU
No. ⑥ 2 taper type lubrication nipples, DIN 71412-A M6, arranged evenly about the circumference and partially recessed

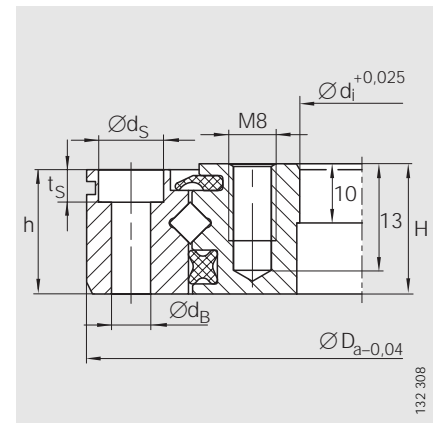

XU
No. ①, ②

Dimension table · Dimensions in mm

Designation	No. ¹⁾	Mass ≈kg	Dimensions										
			D _a	D _{aZT} ²⁾	d _i	d _{iZT} ²⁾	D _i	d _a	H	h	T	t	u
XU 05 0077 ⁵⁾	①	1,4	112	-	40	-	77,5	74	22	21	-	-	-
XU 06 0094 ⁵⁾	②	2,4	140	-	57	-	94,6	93,4	26	25	-	-	-
XU 06 0111 ⁵⁾	③	1,2	145,79	-	76,2	-	111,8	-	15,87	-	-	-	-
XU 08 0120 ⁵⁾	④	4	170	-	69	-	120,6	119,4	30	-	-	-	-
XU 08 0149 ⁵⁾	⑤	3,6	196,85	-	101,6	-	149,6	-	22,22	22,22	-	-	-
XU 12 0179	⑥	7	234	232	124,5	126,5	180±0,2	178±0,2	35	30	5	5	6

¹⁾ Number of associated curve, see static limiting load diagram *Raceway and Fixing screws*.

²⁾ Bearing with centring (suffix ZT), centring lengths (T, t).
No. ① to ⑤ not available in design ZT.

³⁾ Number of holes per ring.

⁴⁾ Maximum radial load. For load carrying capacity of screws see section *Fixing screws*, page 20.

⁵⁾ Special seal.

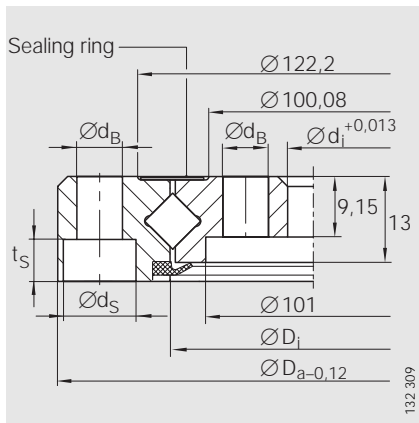

XU
No. ③

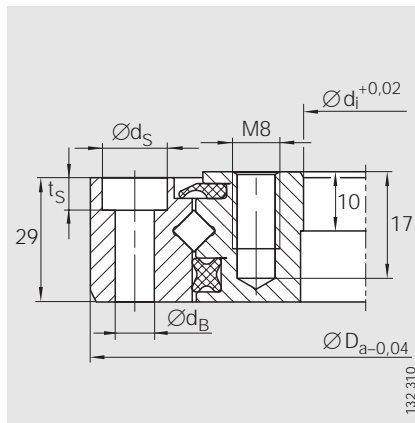

XU
No. ④

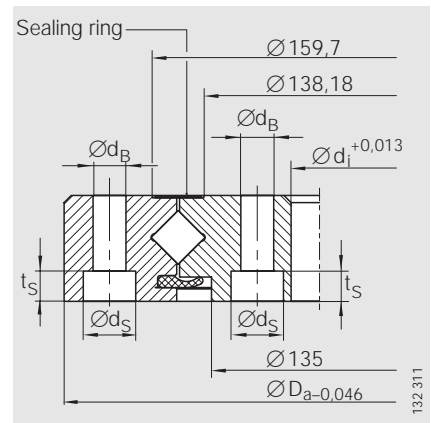

XU
No. ⑤

Fixing holes							Fixing screws $F_{r,perm}$ (friction locking) ⁴⁾ kN	Basic load ratings				Internal clearance Preload
L_a	L_i	$n_a^{3)}$	$n_i^{3)}$	d_B	d_s	t_s		axial		radial		
								dyn. C_a kN	stat. C_{0a} kN	dyn. C_r kN	stat. C_{0r} kN	
97	56	6	6	6,6	11	5,5	5,8	22,4	29	14,3	14,2	0,005 incl. 0,008
120	70	6	6	9	15	6	9,2	32,5	37,5	20,7	18,4	0,005 incl. 0,008
133,1	88,9	8	8	6,9	11	6,35	7,7	36	44,5	22,8	21,5	0,005 incl. 0,02
148	90	6	6	9	15	9	10,5	56	53	35,5	26	0,005 incl. 0,008
177,8	115,8	16	16	6,9	11	6,35	15,4	63	66	40	32,5	0,005 incl. 0,02
214	144,5	12	12	11	-	-	33,6	118	179	75	88	0 incl. 0,02

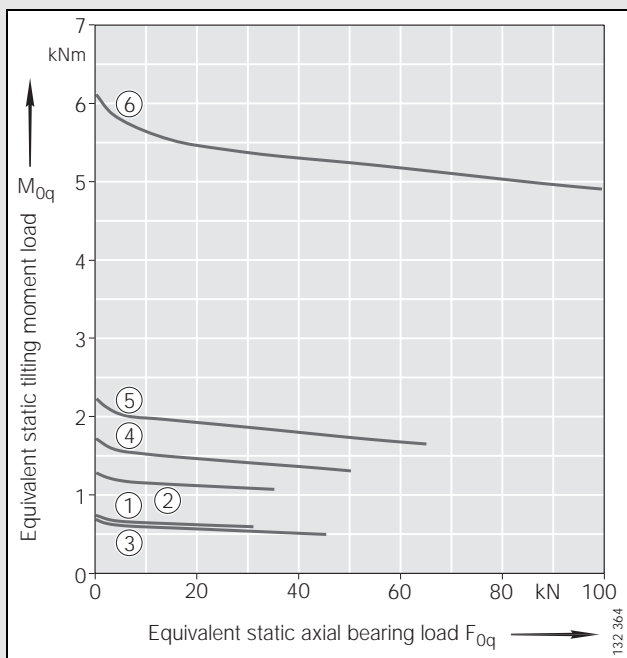

Static limiting load diagram
Fixing screws (supported load)

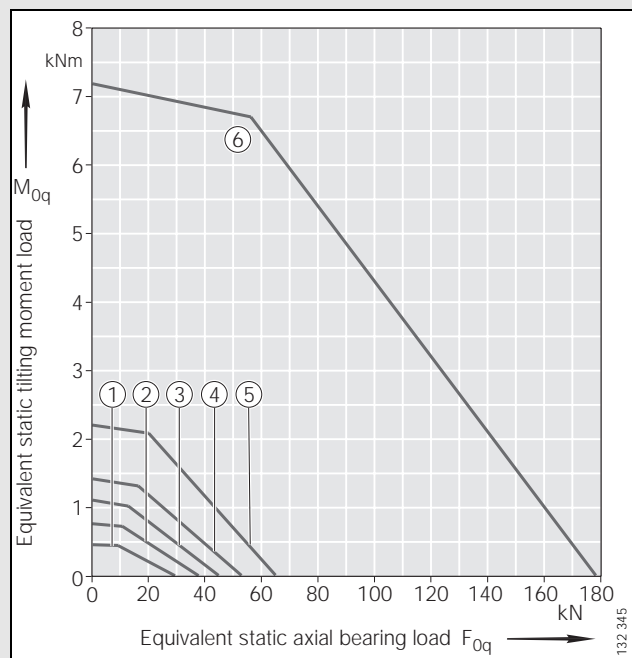

Static limiting load diagram
Raceway (supported load)

Crossed roller bearings

without gear teeth

Series XU

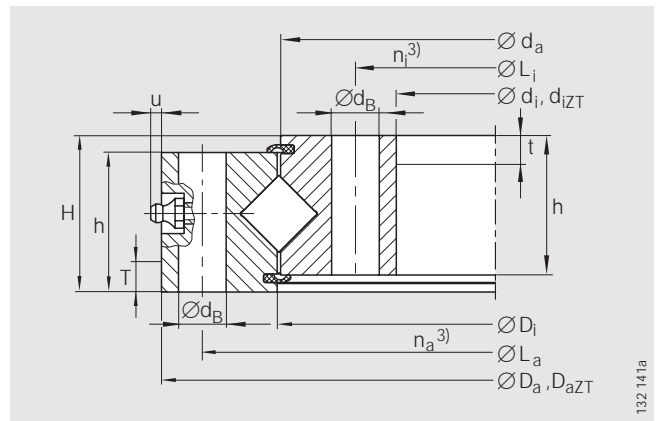

XU

No. ⑫, taper type lubrication nipples, DIN 71412,
 ≈ arranged evenly about the circumference and recessed;
 no. ⑧, ⑩, partially recessed

Dimension table (continued) · Dimensions in mm

Designation	No. ¹⁾	Mass ≈kg	Dimensions											Fixing holes		
			D _a	D _{aZT} ²⁾ -IT8	d _i	d _{iZT} ²⁾ +IT8	D _i	d _a	H	h	T	t	u max.	L _a	L _i	
XU 12 0222	⑦	12	300	-	140	-	224	220	36	30	-	-	-	-	270	170
XU 16 0260	⑧	16	329	327	191	193	261	259	46	41	7	7	3,5	305	215	
XU 08 0264⁵⁾	⑨	6,9	311	-	215,9	-	264,6	263,4	25,4	25,4	-	-	-	295,3	231,8	
XU 16 0405	⑩	25	474	472	336	338	406	404	46	41	7	7	3,5	450	360	
XU 08 0430⁵⁾	⑪	12	480	-	380	-	430,6	429,4	26	26	-	-	-	462	398	
XU 30 0515	⑫	115	646	644	384	386	516	514	86	79	12	12	-	598	432	

¹⁾ Number of associated curve, see static limiting load diagram *Raceway* and *Fixing screws*.

²⁾ Bearing with centring (suffix ZT), centring lengths (T, t).
 No. ⑦, ⑨, ⑪ not available in design ZT.

³⁾ Number of holes per ring.

⁴⁾ Maximum radial load. For load carrying capacity of screws see section *Fixing screws*, page 20.

⁵⁾ No relubrication facility.

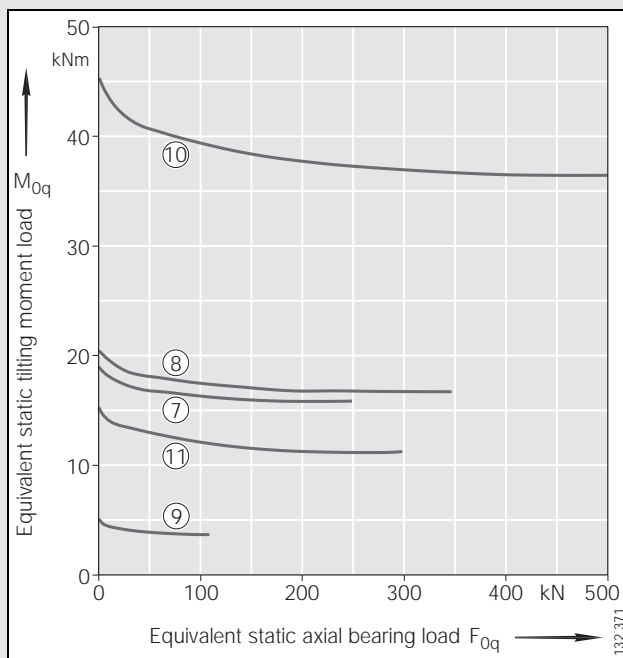

Static limiting load diagram
 Fixing screws (supported load) ⑦, ⑧, ⑨, ⑩, ⑪

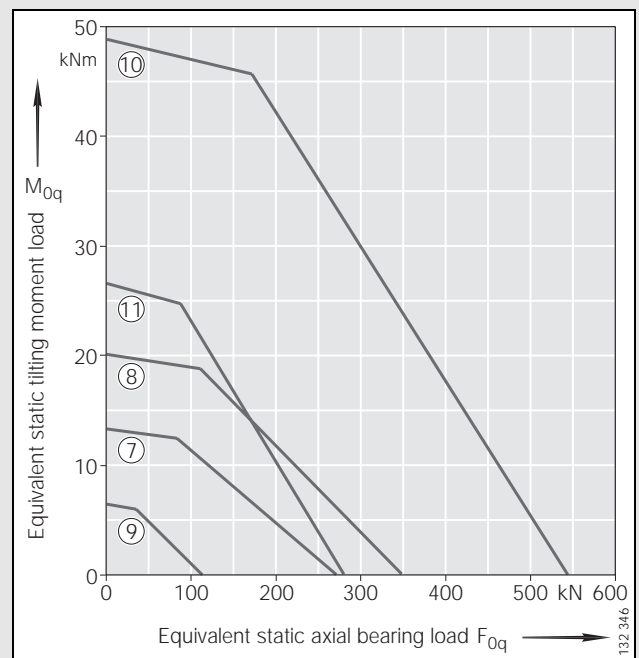

Static limiting load diagram
 Raceway (supported load) ⑦, ⑧, ⑨, ⑩, ⑪

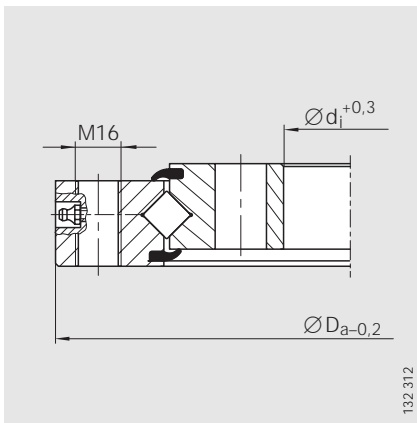

XU
No. ⑦ 2 taper type lubrication nipples,
DIN 71412-A M10×1,
arranged evenly about the circumference

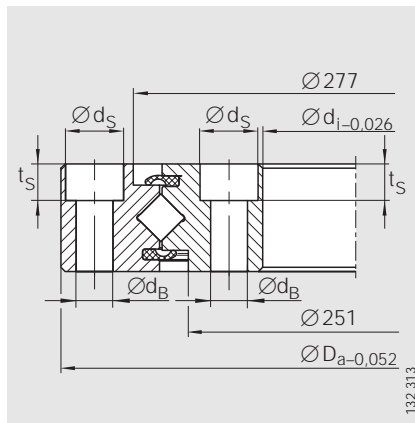

XU
No. ⑨

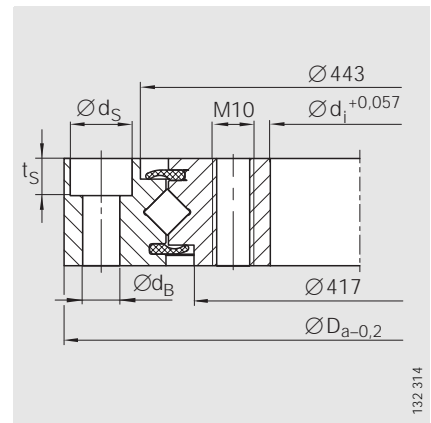

XU
No. ⑪

$n_a^{3)}$	$n_l^{3)}$	d_B	d_s	t_s	Fixing screws $F_{r\text{ perm}}$ (friction locking) ⁴⁾ kN	Basic load ratings				Internal clearance		
						axial		radial		Radial clearance	Axial tilting clearance	Preload
						dyn. C_a kN	stat. C_{0a} kN	dyn. C_r kN	stat. C_{0r} kN			
12	12	18	–	–	65,5	133	275	85	131	0,01 incl. 0,03	0,02 incl. 0,06	–
20	20	14	–	–	82,6	212	350	135	173	Clearance-free	Clearance-free	0 incl. 0,02
12	12	8,7	13,7	8,6	21	85	117	54	57	Clearance-free	Clearance-free	0 incl. 0,02
30	30	14	–	–	123,9	270	550	172	270	Clearance-free	Clearance-free	0 incl. 0,02
20	20	9	15	9	35	110	280	70	138	Clearance-free	Clearance-free	0 incl. 0,02
18	18	26	–	–	313,2	720	1370	455	670	Clearance-free	Clearance-free	0 incl. 0,03

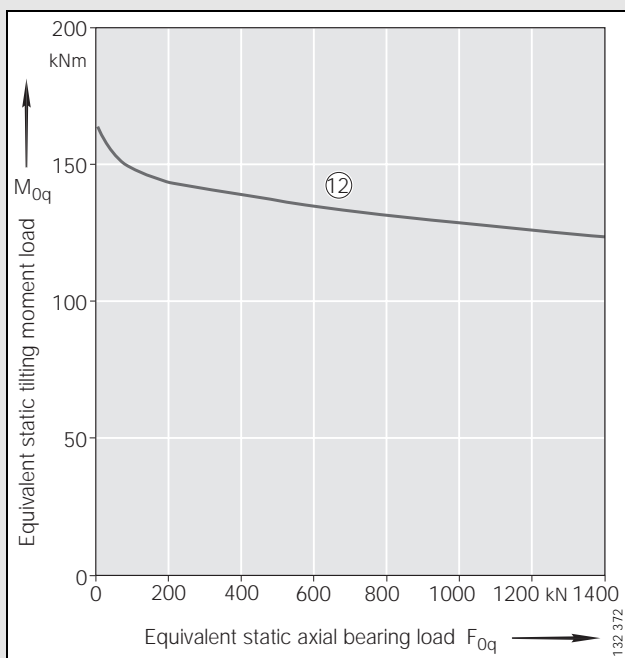

Static limiting load diagram
Fixing screws (supported load) ⑫

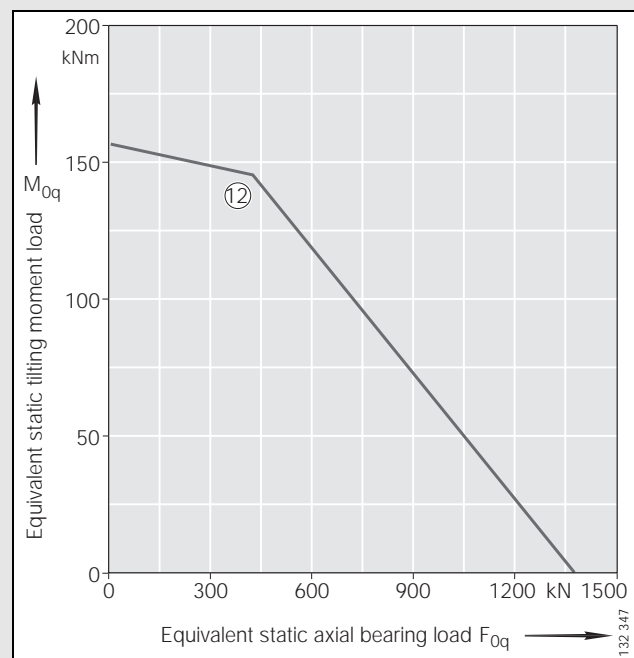

Static limiting load diagram
Raceway (supported load) ⑫

Application examples

Vibratory grinding unit

Carousel and container

Vibratory grinding is a process used, for example, to deburr, descale, smooth, precision grind or polish products of widely varying geometry made from a wide variety of materials.

The unit shown has two containers arranged on a carousel parallel to the central axis. The containers rotate about their common axis.

Grinding elements of a specific shape and the workpieces to be ground are fed into the container as a loose mixture. Due to centrifugal force and the relative motion between the carousel and the containers, a relative motion is induced between the grinding elements and workpieces.

After grinding, the grinding elements and workpieces are separated by means of a separating sieve or magnetic separators. The finished batches are discharged, for example on conveyor belts.

INA design solution

The bearing arrangements of the carousel and containers are based on a four point contact bearing of series VLU 20. The slewing ring is designed such that the three bearing positions in the machine can be fitted with the same bearing.

The bearing arrangement:

- allows the required centre clearance
- allows high circumferential speeds (3,5 m/s)
- is easy to fit and cost-effective.

The bearings can support axial, radial and tilting moment loads and the bearings on the containers can also support the resulting centrifugal forces. The maximum operating temperature is +140 °C.

The particular features of the bearings are:

- ground raceways
- guidance of the rolling elements by a brass strip cage
- optimised surface quality in the bearing gap
- lubrication with lithium complex grease
- FPM seals resistant to high temperatures.

INA product used

- ① Four point contact bearing VLU 20 (special design).

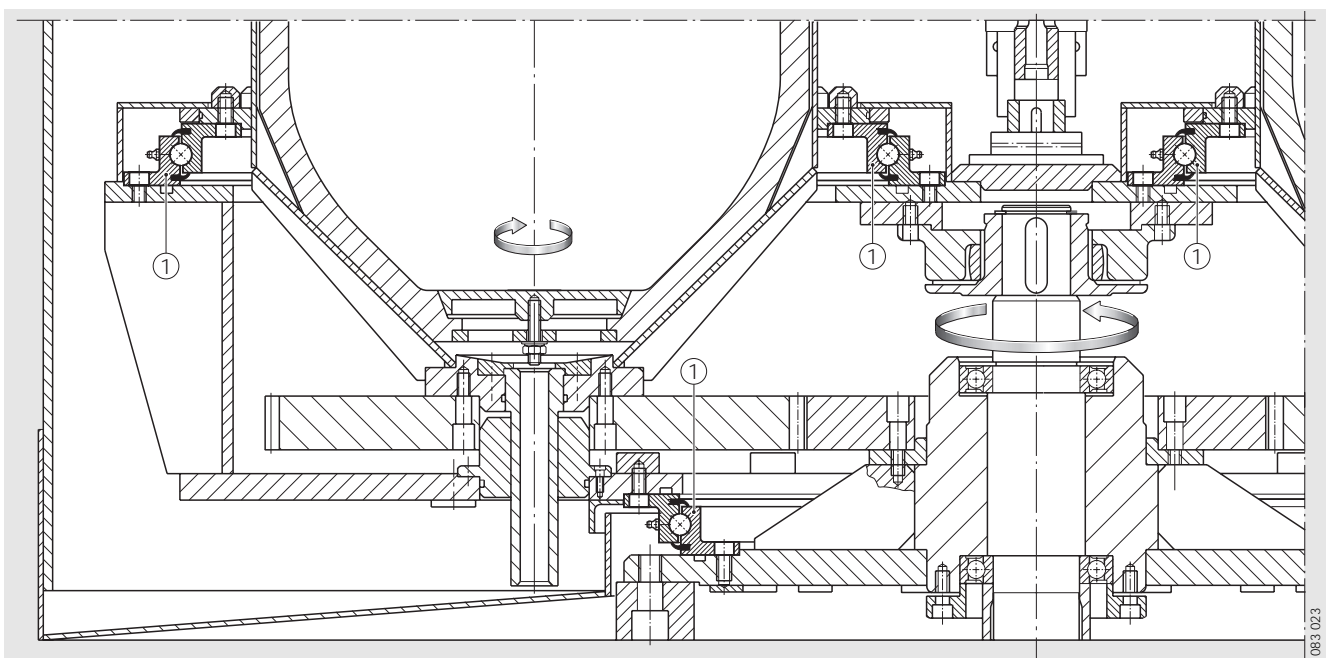

Tandem roller

Self-aligning articulated coupling

The tandem roller described is fitted with two smooth tyres integrated in the front and rear support frames. It compacts asphalt layers, load-bearing layers and anti-frost layers in new construction and repair work. These rollers work on the vibration principle, are highly manoeuvrable and self-manoeuvring within a very small space.

The tyres are linked to each other by steering cylinders and self-aligning articulated couplings. For steering, the articulated coupling moves about the vertical axis. Surface irregularities are compensated by the articulated coupling on the rear tyre.

In order that the tyres can perform oscillating motion about their horizontal axis, a bearing is fitted between the articulated coupling and the rear frame. This bearing is subjected in some instances to very high loads and shock loads. It must support radial forces, axial forces, tilting moments and vibration loads. The coupling must operate without stick-slip and it must be capable of motion even after the tandem roller has been idle for a considerable period. The bearing must be sealed and maintenance-free.

INA design solution

In order to prevent edge loads on the roller, a four point contact bearing VU without gear teeth is fitted as a linkage point. Since only small oscillating movements occur, the bearing can be of a full complement ball design. Its favourable cross-section and the full complement design give a space-saving, compact bearing arrangement with high load carrying capacity. This slewing ring supports radial and axial forces as well as tilting moments with only one bearing position. In order that the steering can operate without stick-slip, the bearing is clearance-free and preloaded. For ease of fitting, the bearing rings are screw mounted to the adjacent construction.

L-section seals on both sides of the four point contact bearing protect the running system against dust, contamination and moisture.

The maintenance-free bearing is greased with a high quality lithium complex soap grease KP2N-20 to DIN 51825. It can be relubricated via taper type lubrication nipples.

For steering motion about the vertical axis, maintenance-free ELGOGLIDE® angular contact spherical plain bearings GE..SW are fitted.

INA products used

- ① Four point contact bearing VU (special bearing)
- ② ELGOGLIDE® angular contact spherical plain bearing GE..SW

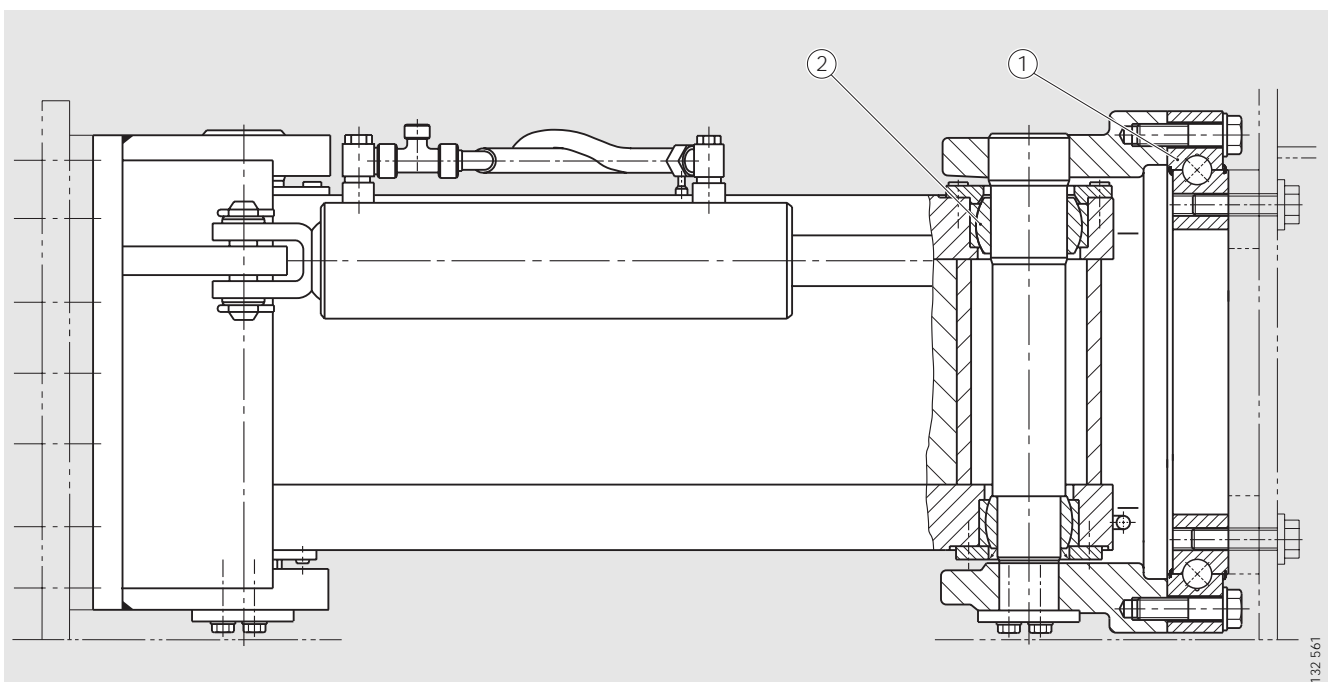

Vertical machining centre

Tool changer

Machining centres of this machine concept are used for milling operations on tools, shapes and production parts. Due to their flexibility, precision, cutting performance and favourable set-up and ancillary costs, they are highly suitable not only in the traditional areas of tool and die production but also in sectors such as medical equipment, the optical industry, aerospace and automotive engineering.

The tool moves in three axes. Due to the high dynamic characteristics irrespective of the workpiece, high rapid traverse movement and feed values are possible. Tool change is effected without the use of a gripper arm and is carried out automatically by the pick-up method. The tool magazine is in the form of a ring magazine and has 38 tool spaces. For more complex machining tasks, it can be expanded to 87 spaces.

In order to reduce set-up and ancillary costs, the magazine must allow rapid tool change while the tools are nevertheless held securely in the magazine. The changer must support the mass of the tools and must be maintenance-free. In order to prevent tool contamination, the magazine must be located in a protected area of the machine. The bearing must be compact and require little space while having an effective sealing system.

INA design solution

A four point contact bearing VI with gear teeth is used as a tool magazine. The plastic holders for the tools are screw mounted to the outer ring of the bearing. This saves on space and reduces the total number of parts for the magazine. The tool changer is rotated by means of the gear teeth on the bearing inner ring and a pinion; the tools are positioned precisely by the machine control system.

The cross-section of the four point contact bearing is very small in relation to its bearing diameter. This gives a very compact construction requiring little axial space. The magazine is integrated in the machine body outside the machining area and is loaded with tools from the side.

An axial seal on the underside of the four point contact bearing and a radial seal profile on the upper side protect the running system against contamination and moisture. The radial seal has an additional outer labyrinth seal.

The bearing is greased with a high quality lithium complex soap grease KP2N-20 to DIN 51825 and can be relubricated via two taper type lubrication nipples.

INA product used

- ① Four point contact bearing VI (special bearing)

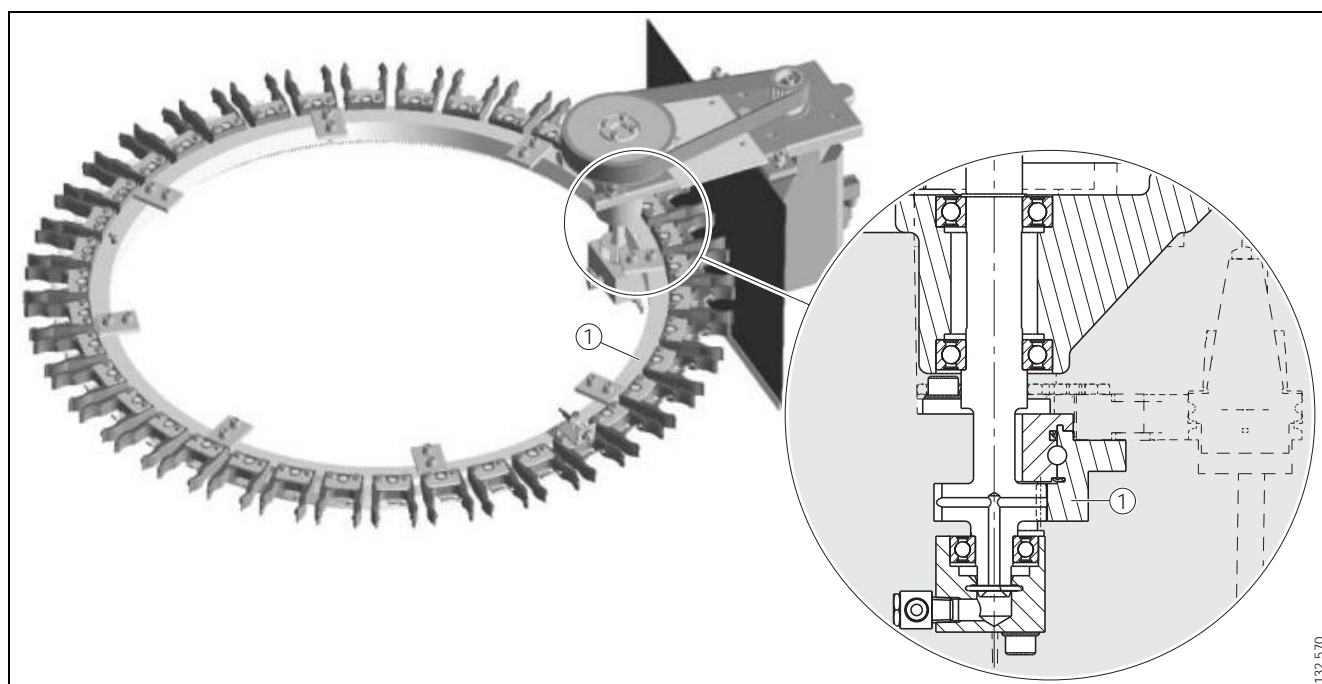



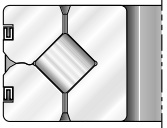
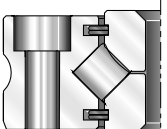
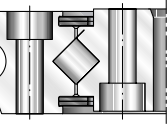
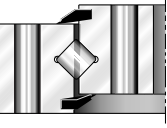

Crossed roller bearings

for high precision applications

Characteristics Crossed roller bearings	Bore diameter	Load carrying capacity ¹⁾			Tilting rigidity ¹⁾²⁾	Accuracy ¹⁾		Friction ¹⁾²⁾
		radial stat.	axial on both sides stat.	tilting moment stat.		radial	axial	
SX  <small>132 478</small>	70 mm to 500 mm	■ ■	■ ■	■ ■	■ ■	■ ■	■ ■	■ ■
XV  <small>132 481</small>	30 mm to 110 mm	■ ■	■ ■	■ ■	■ ■	■ ■	■ ■	■ ■
XSU 08  <small>132 479</small>	130 mm to 360 mm	■ ■	■ ■	■ ■	■ ■	■ ■	■ ■	■ ■
XSU 14  <small>132 480</small>	344 mm to 1024 mm	■ ■	■ ■	■ ■	■ ■	■ ■	■ ■	■ ■

■ Design of crossed roller bearing.

¹⁾ The data refer to the smallest and largest bearing diameters.

Maximum circumferential speed with		Internal clearance			Sealed on both sides	Operating temperature	Anti-corrosion protection ³⁾	Features Publication
grease lubrication	oil lubrication	Standard clearance	Low clearance RLO	Preloaded				
4 m/s ($n \cdot D_M = 76\,400$) with standard clearance 2 m/s ($n \cdot D_M = 38\,200$) with preload	8 m/s ($n \cdot D_M = 152\,800$) with standard clearance 4 m/s ($n \cdot D_M = 76\,400$) with preload	■	■	■		-25 °C to +80 °C	■	 KSX
2 m/s ($n \cdot D_M = 38\,200$) with preload	4 m/s ($n \cdot D_M = 76\,400$) with preload	adjustable from clearance-free to preloaded			■	-25 °C to +80 °C	■	 KSX
2 m/s ($n \cdot D_M = 38\,200$) with preload	4 m/s ($n \cdot D_M = 76\,400$) with preload			■	■	-25 °C to +80 °C	■	 KSX
2 m/s ($n \cdot D_M = 38\,200$) with preload	4 m/s ($n \cdot D_M = 76\,400$) with preload			■	■	-25 °C to +80 °C	■	 KSX

²⁾ Determined at 20% of maximum permissible tilting moment, without axial or radial load and with moderate preload.

³⁾ Special design with INA special plating Corrotect®.



Crossed roller bearings

for high precision applications



Features

Crossed roller bearings

- are units comprising outer rings, inner rings, rolling elements (cylindrical rollers) and spacers
 - depending on the series, the inner ring or outer ring is unsplit or is split in a circumferential direction
- can, due to the X arrangement of the rolling elements, support axial loads from both directions as well as radial loads, tilting moment loads and any combination of loads by means of a single bearing position
 - this allows designs with two bearing positions to be reduced to a single bearing position
- have high rigidity and very high running accuracy
- are preloaded and, with grease lubrication, are suitable for circumferential speeds up to
 - 2 m/s ($n \cdot D_M = 38\,200$)
- are greased but can alternatively be lubricated with oil
- are particularly easy to fit
- are also available in a corrosion-resistant design with the INA special plating Corroctect®.

Crossed roller bearings SX

- have standard clearance or are preloaded
- are located in the adjacent construction by means of clamping rings
- are suitable, with standard clearance, for circumferential speeds:
 - with oil lubrication up to 8 m/s ($n \cdot D_M = 152\,800$)
 - with grease lubrication up to 4 m/s ($n \cdot D_M = 76\,400$)
- are preloaded and suitable, with oil lubrication, for circumferential speeds up to
 - 4 m/s ($n \cdot D_M = 76\,400$).

Crossed roller bearings XSU

- are preloaded
- are screw mounted by means of the bearing rings directly to the adjacent construction.

Crossed roller bearings XV

- are screw mounted by means of the outer ring to the adjacent construction
 - the inner ring is located by means of a locknut
- can be adjusted very precisely to give a specific clearance or preload by means of the locknut.

Crossed roller bearings



SX



132 450

- conform to dimension series 18 to DIN 616
- cylindrical rollers to DIN 5402, spacers made from plastic
- outer ring split in a circumferential direction and held together by three retaining rings
- not sealed
- for operating temperatures from -25 °C to $+80\text{ °C}$
- for shaft diameters from 70 mm to 500 mm



XV



132 451

- cylindrical rollers to DIN 5402, spacers made from plastic
- inner ring split in circumferential direction
- sealed on both sides
- for operating temperatures from -25 °C to $+80\text{ °C}$
- for shaft diameters from 30 mm to 110 mm
- two lubrication nipples radially, two lubrication nipples axially



XSU



132 452

- series XSU 08
- cylindrical rollers to DIN 5402, spacers made from plastic
- centring on the inside and outside diameter
- sealed on both sides
- for operating temperatures from -25 °C to $+80\text{ °C}$
- for shaft diameters from 130 mm to 360 mm
- two lubrication nipples radially, two lubrication nipples axially

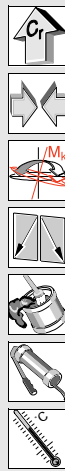

XSU



132 453

- series XSU 14
- also available with internal or external gear teeth
- cylindrical rollers to DIN 5402, spacers made from plastic
- centring on the inside and outside diameter
- sealed on both sides
- for operating temperatures from -25 °C to $+80\text{ °C}$
- for shaft diameters from 344 mm to 1024 mm

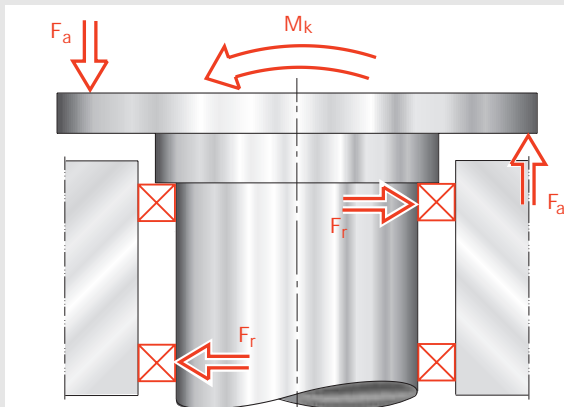

Conventional bearing arrangement with two bearing positions

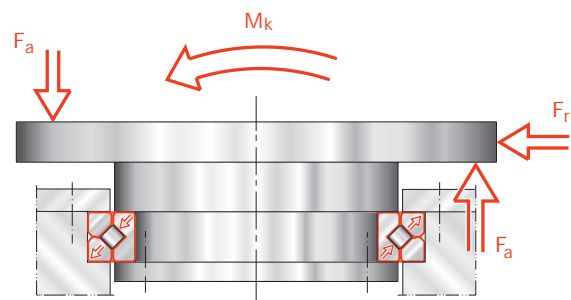

Optimised bearing arrangement with one crossed roller bearing

132 463a



**Schaeffler Technologies
AG & Co. KG**

Industriestraße 1 – 3
91074 Herzogenaurach
Germany
Internet www.ina.com
E-Mail info@schaeffler.com

In Germany:

Phone 0180 5003872
Fax 0180 5003873

From other countries:

Phone +49 9132 82-0
Fax +49 9132 82-4950

Every care has been taken to ensure the correctness of the information contained in this publication but no liability can be accepted for any errors or omissions. We reserve the right to make technical changes.

© Schaeffler Technologies AG & Co. KG
Issued: 2012, February

This publication or parts thereof may not be reproduced without our permission.

404 GB-D









Each section in Catalogue 404 begins with a description of the product series and their features.

The essential characteristics of the bearings are indicated by means of pictograms.

The advantages of this type of presentation include:

- the reading required is reduced
- the required information can be accessed more quickly
- a direct comparison between alternative bearings is possible.

Definition of pictograms

Pictogram	Description
	The bearings can support radial forces
	The bearings can support axial forces in both directions
	The bearings can transmit tilting moments
	The bearings are sealed on both sides
	The bearings are greased
	The bearings can be relubricated
	The permissible operating temperature differs from the standard values
	This pictogram indicates the dimension table
	If this information is not adhered to, there is a direct or indirect risk to the product and/or the adjacent construction