

NIMB

MinebeaMitsumi, Inc

Precision Ball Bearing Products

Miniature / Small-diameter Rolling Ball Bearings



■ Introduction

Thank you for your continued patronage of MinebeaMitsumi products. Since our establishment in 1951 as Japan's first manufacturer of miniature rolling ball bearings, we have expanded the scale of our products to include miniature, instrument and small-diameter rolling ball bearings. Currently our production is carried out in 13 plants in Japan, the United States, Singapore, Thailand, China, etc. Ball bearings are composed of such parts as outer rings, inner rings, balls, retainers and shields. MinebeaMitsumi manufactures these parts in-house and has established an integrated production system that encompasses processing to assembly. We have the mother plant in Japan and cooperate with plants in various countries to enable stable production of high-quality ball bearings at any site.



■ About the Revision

This catalog revision is centered on the addition of the modified rating life newly specified in **JIS B 1518:2013**. (Refer to pages 20 to 22 for details)

Small-diameter and miniature rolling ball bearings are used in a wide range of applications such as computers, automobiles, home appliances and industrial machinery. In particular, the proper selection of rolling ball bearings is important as the performance of rolling ball bearings is greatly involved in reducing the size/weight and improving the efficiency of equipment.

On the other hand, the reduction of environmentally hazardous substances is also important, thus raising requirements on both bearing performance and environmental measures. In response to these requirements, MinebeaMitsumi is actively involved in the development, design, manufacturing and distribution of products, delivering environmentally friendly ball bearings. We hope that this catalog will help you select the ideal small-diameter and miniature ball bearings.

MinebeaMitsumi's Activities.....	4
Warnings and Precautions	5
1. Technical Information	
1-1 Bearing Type	8
1-2 Names and Symbols	10
1-3 Part Numbering System	11
1-4 Selecting a Bearing	
① Specification Process.....	14
② Application Structure, Required Performance, Environment.....	16
③ Material	17
④ Shield and Seal.....	18
⑤ Retainer.....	19
⑥ Load Rating and Rating Life.....	20
⑦ Tolerance and Precision Grade	24
⑧ Measurement Methods	28
⑨ Internal Clearance.....	30
⑩ Fits	31
⑪ Designs of Shaft and Housing.....	33
⑫ Preload.....	34
⑬ Displacement	36
⑭ Torque.....	37
⑮ Vibration by forced rotation	38
⑯ Noise	40
⑰ Compatibility with Resin Parts.....	41
⑱ Lubricants.....	42
1-5 Handling of a Bearing	44
1-6 Trouble Symptoms, Causes and Countermeasures.....	48

2. Dimensions

● Radial deep groove ball bearings	
Metric size: Basic (chrome steel / stainless steel)	52
Metric size: With flange	
(chrome steel, stainless steel)	60
Metric size: With retaining ring (chrome steel)	64
● Thrust ball bearings	
Metric size: Basic (stainless steel).....	65
● Radial deep groove ball bearings	
Inch size: Basic (chrome steel, stainless steel)	66
Inch size: With flange	
(chrome steel, stainless steel)	68
3. Other Products	70
4. Terminology	72
5. Appendix.....	74
6. Inspection Equipment.....	78
7. Sales Offices	
List of domestic sales offices.....	80
List of overseas sales offices.....	81
8. Production Bases	82



MinebeaMitsumi's Activities

■ MinebeaMitsumi Group's CSR

Basic Approach

The MinebeaMitsumi Group believes that enterprises have a mission to contribute to the sustainable development of the global environment and of humanity, not only through strict adherence to laws and regulations, but also through fair and proper management of our business in accordance with business ethics. To achieve this mission, we have established the "Five Principles" as our basic management policy, and on the basis of this policy, formulated the MinebeaMitsumi Group Basic CSR Policy and the MinebeaMitsumi Group's CSR Implementation Principles to guide our CSR activities. We also stress the importance and strive to fulfill the Ten Principles of the UN Global Compact, to which we announced participation in 2012.

The Five Principles

- Be a company where our employees are proud to work
- Earn and preserve the trust of our valued customers
- Respond to our shareholders' expectations
- Work in harmony with the local community
- Promote and contribute to global society

MinebeaMitsumi Group Basic CSR Policy

As a manufacturer of precision products supporting society, the MinebeaMitsumi Group is working toward stable supply and making reliable products with low energy consumption widely available, to contribute to the sustainable development of the global environment and of humanity.

The MinebeaMitsumi Group's CSR Implementation Principles

① The Five Principles and our Code of Conduct

In promoting CSR activities, the MinebeaMitsumi Group will appropriately manage the organization in accordance with the "Five Principles," and adhere to its Code of Conduct.

③ Continuous improvement and raising of awareness

We will put forth goals to be achieved, based on understanding the MinebeaMitsumi Group's social responsibilities and the key problems that need to be addressed, and continue to improve our CSR activities through implementation and continual review. We will also strive to raise awareness of CSR among all employees through CSR activities.

② Creation of Social Value through Products

As a manufacturer of precision products supporting society, the MinebeaMitsumi Group is actively developing reliable products which reduce energy consumption, and making them widely available.

④ Dialogue with stakeholders

Constructive dialogue with stakeholders (employees, customers, shareholders, local communities, global society, suppliers, and the environment) allows us to meet expectations and respond to requests, and we will improve transparency and accountability in our corporate activities.

■ The MinebeaMitsumi Group's Environmental Management

Basic Approach

The MinebeaMitsumi Group has established an environmental management system based on the MinebeaMitsumi Group Environmental Policy, and all Group companies are striving to contribute to the protection of the earth's environment and the sustainable development of human kind.

As examples of specific initiatives in this regard, we adopted highly energy-efficient equipment and processes and plan to reduce total Group CO₂ emissions per basic unit of output by 5% by FY2015 compared with the baseline year (FY2010). We are also strengthening initiatives to minimize waste materials and wastewater from our plants in order to effectively utilize raw materials and water resources. We also make contributions to the environment through our products, including the active development of communications control technologies, sensors and new materials which are central to energy management in highly efficient motors, lighting, and energy conversion devices, as well as "smart" buildings, plants, and urban residential environments.

The MinebeaMitsumi Group Environmental Policy

The MinebeaMitsumi Group conducts business in consideration of the environment in accordance with "the Five Principles", and contributes to global environmental protection and the sustainable development of mankind.

1. Development and design of environmentally friendly products
2. Environmental considerations in manufacturing
3. Environmental considerations in procurement and distribution
4. Environmental considerations for national and local governments and surrounding areas
5. Contribution to the global society
6. Raising awareness of environmental protection among our employees

Warnings and Precautions

⚠ Warnings

- NMB is not responsible for damages to products used in applications that are unforeseeable by MinebeaMitsumi Group.
- MinebeaMitsumi is not responsible for any damage caused by ball bearings if modified in any way.
- MinebeaMitsumi is not responsible for any damage if application conditions and/or equipment specifications are changed after determining the ball bearing specification.
- The products described in this catalog are not manufactured for nuclear equipment. MinebeaMitsumi is not responsible for damages caused by products used for nuclear applications.

⚠ Precautions

Selecting a Bearing

In the following circumstances, consult us to make selection.

- When used in environment of high-speed rotation, high precision, high/low temperature, high/low humidity and high load.
- When used as important parts such as in aircrafts, space-related equipment, public facilities of electricity and gas, etc, automobiles and automobile-related parts, transportation/logistics equipment, multi-story parking equipment, lifting equipment, medical equipment, game machines/equipment, etc.
- When resin is used for parts around rolling ball bearings. * Depending on the type of resin, grease or oil may cause the resin parts to deteriorate or break.
- When current may flow through the rolling ball bearings.
- When used in an environment that corrodes metals (corrosive gas, vapor, liquid).

Installation into equipment

Scratches, indentations or foreign matter entering the bearings can cause noise and shorten the life of the bearings, so pay attention to the following points.

- Do not apply impact.
- Keep the operating environment clean.

Storage and transportation of equipment

When vibration is applied to equipment incorporating ball bearings, wear marks due to fine movement (fretting) occur inside the bearings, causing noise and shortened life. Also, when impact is applied, the bearings will be scratched or indented, causing deterioration and shortening life of the rolling ball bearings, so pay attention to the following points.

- Consider the packaging of equipment incorporating rolling ball bearings so that vibrations and impacts can be buffered from the outside. Also, make sure the packaging does not allow rotary objects such as impellers to move.
- Be careful not to subject the equipment to vibration or impact during transportation.

Bearing Storage

The performance of rolling ball bearings will decline due to adhesion/intrusion of foreign matter, rusting and deterioration of grease, which may cause failure or damage. Be sure to observe the following when storing.

- Avoid high-temperature and high-humidity environments. Even while in package, do not place it directly on the floor. Store on a pallet to insure ventilation.
- Avoid use in an environment that corrodes metals (corrosive gas, vapor, liquid).
- Do not unpack unless necessary, and do not leave the ball bearings unprotected. When unpacking, use rubber gloves, etc. to avoid touching with bare hands.

Operation test

- After assembling the ball bearing, perform an operation test to make sure it rotates normally. During operation test, increase the rotational speed as gradually as possible.
- If any abnormalities are found during the operation check, stop operation immediately and carry out the check. Do not reuse ball bearings found to be abnormal.

Other

- Please confirm the types of lubricants at the time of purchase. Some sealed and shielded bearings in the market use only oil lubrication.
- Some ball bearings are subject to export restrictions under the Foreign Exchange and Foreign Trade Law. To export these cargoes, an export license from the Minister of Economy, Trade and Industry of Japan is required.
- The contents of this catalog are subject to change without notice.

1



Technical Commentary

1-1 Bearing Type

Rolling ball bearings manufactured by MinebeaMitsumi are mainly single-row radial deep groove ball bearings. In addition to the open type, radial deep groove ball bearings are available with shields and seals to prevent foreign matter from entering and grease from leaking out.

Flange type and snap ring type bearings are available for improved housing fits. NMB also produces ultra thin type radial ball bearings, thrust ball bearings, special bearings, etc.



Deep groove ball bearings (R-, L-, RI-)

Characteristics: This is the most common type of radial ball bearing
It can support not only radial loads but also axial loads in both directions

Types: Open shielded, sealed
Dimensions: Metric size, inch size



Deep groove ball bearings with flange (RF-, LF-, RIF-)

Characteristics: This is a radial ball bearing with a flange featured on one side of the outer ring surface.
Enables easy positioning in the axial direction when mounting to the housing

Types: Open shielded, sealed
Dimensions: Metric size, inch size
* Standard bearing material is stainless steel



Deep groove ball bearings with outer ring retaining ring (RNR-, LNR-)

Characteristics: This is a radial ball bearing with an external retaining ring featured on one side of the outer ring surface.
Enables easy positioning in the axial direction when mounting to the housing

Types: Open shielded
Dimensions: Metric size
* Standard bearing material is high carbon chromium bearing steel

Ultra-thin ball bearings (A-)

Characteristics: The bore relative to the outer diameter is larger than those of standard radial ball bearings.

Types: Open shielded
Dimensions: Metric size
* Standard bearing material is stainless steel



Thrust ball bearings (T-)

Characteristics: A thrust ball bearing supports axial loads, but not radial loads.

Types: With raceway, without raceway
Dimensions: Metric size
* Standard bearing material is stainless steel



Special bearing (AS-)

Characteristics: Bearings with additional functions such as alterations to the outer ring surface.

Types: With grooves on the outer ring surface, with O-ring, etc.



1-2 Names and Symbols

A rolling ball bearing is composed of an outer and inner ring (raceway rings), balls (rolling elements), and a retainer. Shields, seals, flanges, and snap rings can also be included.

Components and Names of Rolling Ball Bearings

Part name

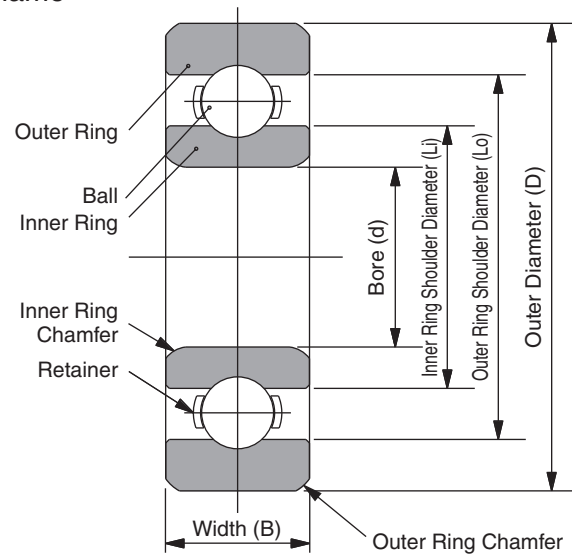

Basic

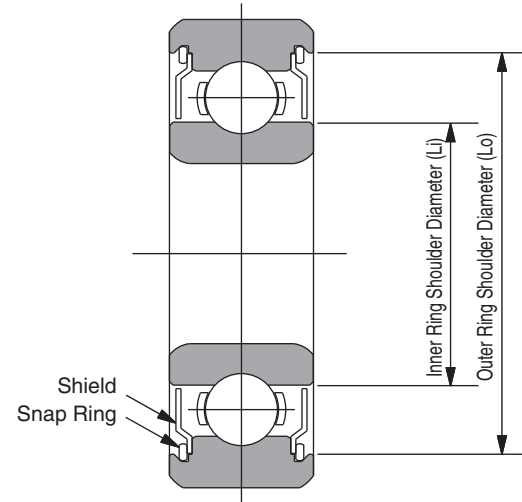

Shielded

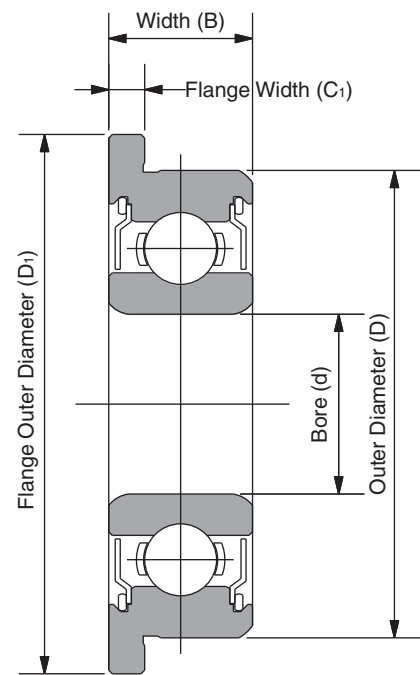

With flange

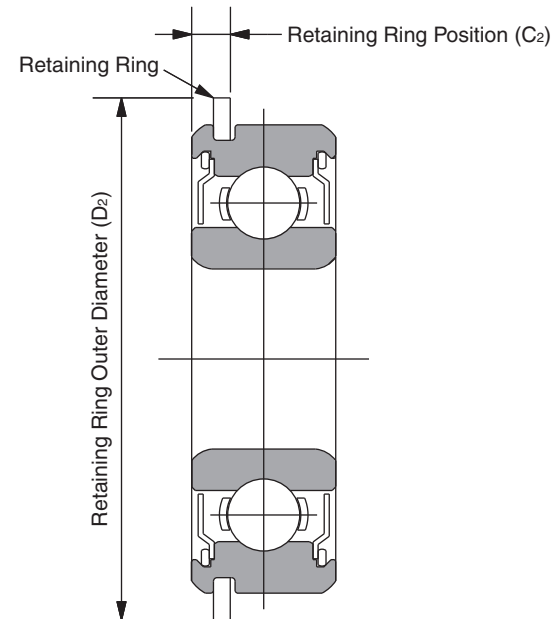

With snap ring

1-3 Part Numbering System

The NMB part numbering system is comprised of the base part number and specification.

The NMB part numbering system is unique to MinebeaMitsumi. The JIS part numbering system is based on the identification system specified in JIS B 1513.

NMB Part Numbering

Model Name						
Basic Symbols			Auxiliary Symbol			
Material Symbol	Series Symbol	Dimension Symbols	Shield and Seal Symbols	Noise and Special Symbols	Retainer Symbols	
See P.17 for details	-	-	P.18	-	P.19	
Display example	DD	R-	1560	ZZ	MT	R
No display	■ Radial ball bearings (metric)	Outer diameter - inner diameter dimensions are listed.	No display	Open type	MT	R
SUJ 2 or equivalent bearing steel	R- (RF-) Thick type (with flange)	Ex) Metric size	Z	Steel plate shield (Fixed with snap ring)	Low-noise motor specification	Ribbon retainer (steel plate)
DD	L- (LF-) Thin type (with flange)	1560 outer diameter: 15 mm	H (Pressed)	Steel plate shield	SD	H
Martensitic stainless steel	A- Ultra-thin type	inner diameter: 6 mm	K (Staked)	Steel plate shield	Special design specification	Crown retainer (steel plate)
CE	RNR- Thick type with snap ring	Ex) Inch size	W		Wider than standard	MN
Outer/Inner ring: SUJ 2 or equivalent bearing steel	LNR- Thin type with snap ring	418 outer diameter: 4 1/16 inch	Y		Narrower than standard	Resin retainer (Polyamide reinforced)
Ball: Ceramic	■ Radial ball bearings (inch)	inner diameter: 1/8 inch	S	Rubber seal, non-contact type		
	RI- All inch types	X Internal design symbol	D	Rubber seal, contact type		
	(R-) *Used for some inch types	Displayed after the basic symbol when there is a difference in internal design between the basic symbols.	When mounting on both sides, they are displayed on top of each other.			
	RIF- Flange type	Ex) 1560X2	Ex) ZZ, DD, etc.			
	■ Thrust ball bearings	Outer diameter: 15 mm				
	T-	Inner diameter: 6 mm				
	■ Special type	Internal design X2 type				
	AS- Special shape					

Specification name			
Class symbol	Clearance symbol	Lubricant symbol	Grease filling amount symbol
P.24	P.30	P.42	P.42
P0	P25	LY121	L
Metric dimension series	Radial Clearance	Lubricant type	No display
P0 JIS Class 0	P13 2.5µm~ 7.5µm	LO Oil	Standard filling amount
P5 JIS Class 5	P24 5.0µm~10.0µm	LG Grease	25% to 35%
	P25 5.0µm~12.5µm	LY Grease or oil	X 5%~10%
Inch dimension series	P58 12.5µm~20.0µm	LD No lubricant	L 10%~15%
A1 ABEC 1			T 15%~20%
A3 ABEC 3P	* Display method		H 40%~50%
A5 ABEC 5P	The lower and upper limits in the radial direction are displayed in inches.		J 50%~60%
	Ex) Radial clearance		
	For 5.0 µm to 12.5 µm		
	when converted to inches		
	→ 0.0002 in to 0.0005 in		
	Displayed using this number = "P25".		
			Note 1 The filling amount is expressed as a percentage of the internal space volume.
			Note 2 For some miniature bearings, the filling amount may be adjusted.

JIS Part Numbering

Model Name					
Basic Symbols		Auxiliary Symbol			
Material Symbol	Series Symbol	Inner Diameter Symbol	Retainer Symbol	Shield and Seal Symbol	Special Symbol
See P.17 for details	-	-	P.19	P.18	-
Display example No display	60	8	No display	ZZ	NR
No display	60	5	No display	No display	SD
SUJ 2 or equivalent bearing steel	62	6	Ribbon retainer	Open type	Special design specification
CE	63	:	MN	Steel plate shield	NR
Outer/Inner ring: SUJ 2 or equivalent bearing steel	Single-row deep groove ball bearings	00	Resin retainer (Polyamide reinforced)	S	Type with snap ring
Ball: Ceramic		01		D	
		X	* Resin retainer is also available in other resin materials.	When mounting on both sides, they are displayed on top of each other. Ex) ZZ, DD, etc.	
		* Internal design symbol Displayed after the basic symbol when there is a difference in internal design between the basic symbols.			
Specification name					
Clearance symbol	Sound symbol	Class symbol	Lubricant symbol	Grease filling amount symbol	
P.30	-	P.24	P.42	P.42	
M3	MT	P5	LY121	L	
Radial Clearance	MT Low-noise motor specification	No display JIS Class 0	Lubricant type	No display Standard filling amount	
M2 3µm~8µm	SM General specification	P5 JIS Class 5	LO Oil	25%~35%	
M3 5µm~10µm			LG Grease	X 5%~10%	
M4 8µm~13µm			LY Grease or oil		L 10%~15%
M5 13µm~20µm			LD No lubricant		T 15%~20%
			H 40%~50%		
				J 50%~60%	
				Note 1 The filling amount is expressed as a percentage of the internal space volume.	

Display example is shown below.

NMB type display example ①

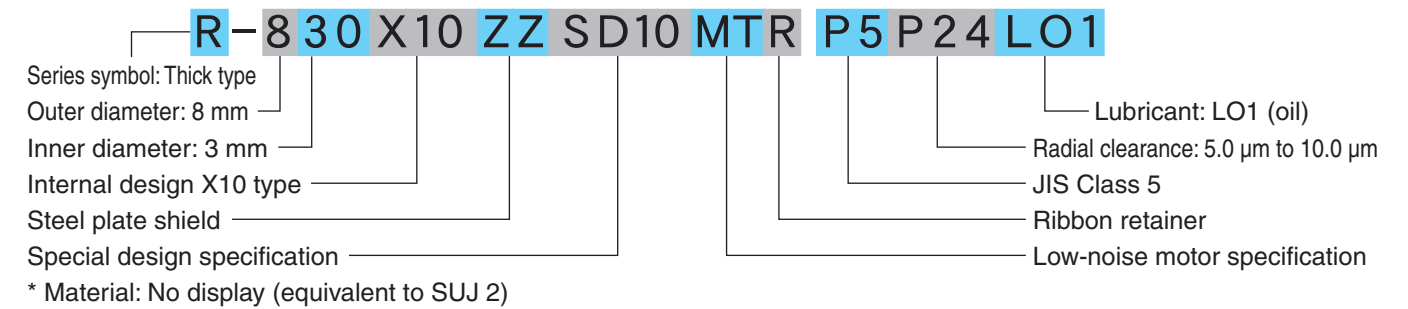

NMB type display example ②

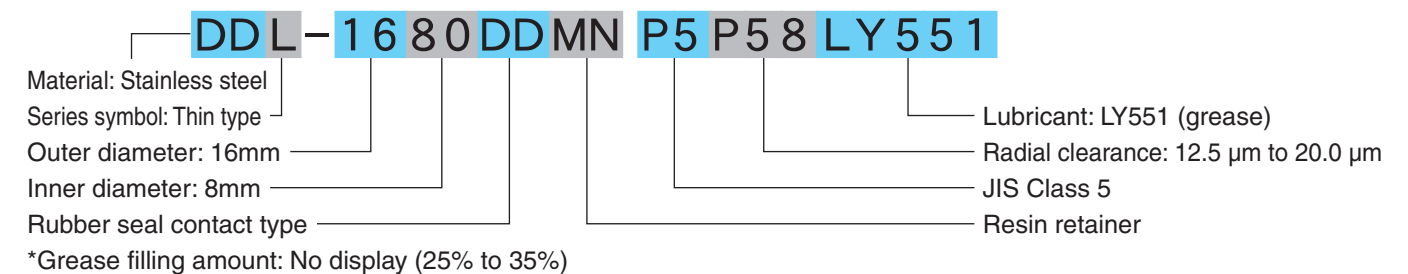

JIS Part Numbering display example

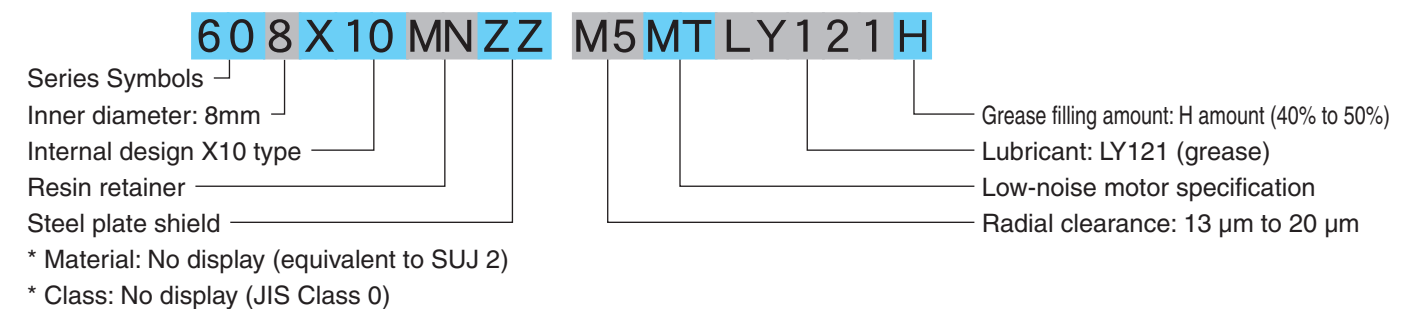

1-4 Selecting a Bearing

① Selecting Process

To select a ball bearing part number and specification properly, it is necessary to fully understand the required performance of the ball bearing by confirming the structures, dimensions, environment, and conditions of each application using the ball bearing. The process of selecting a ball bearing is shown below.

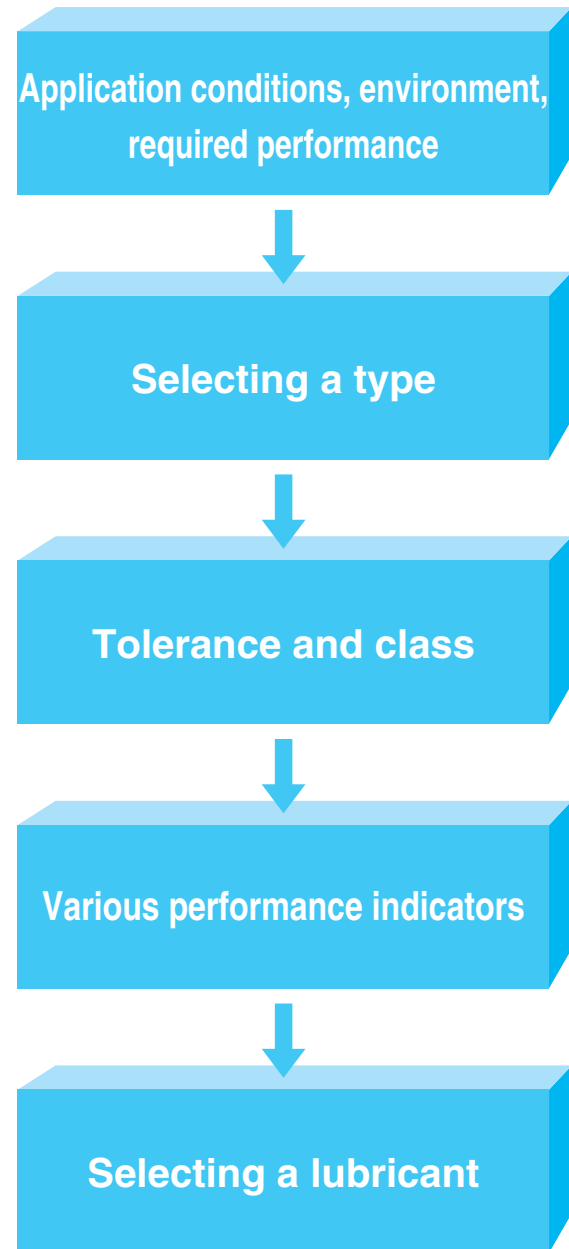

- Application conditions, environment and required performance** (P.16)
- Equipment structure and functions
 - Operating environment (temperature, humidity, vibration, dust, etc.)
 - Load
 - Dimensions and materials of shaft and housing
 - Rotational speed, rotation precision, rotating ring
 - Torque
 - Sound
 - Life
 - Restricted substances
 - Special environmental conditions

- Selecting a type**
- Bearing material (P.17)
 - Bearing dimensions (Refer to the dimensions on P.51)
 - Shield and seal structure (P.18)
 - Retainer (P.19)
 - Rated load and life (P.20 to 22)

- Tolerance and class**
- Tolerance and tolerance value (P.24 to 27)
 - Measurement method (P.28, 29)

- Various performance indicators**
- Internal Clearance (P.30)
 - Fitting (P.31, 32)
 - Shaft and Housing Design (P.33)
 - Preload (preload and rigidity) (P.34, 35)
 - Displacement (P.36)
 - Torque (P.37)
 - Vibration Due to Forced Rotation (P.38, 39)
 - Sound (P.40)
 - Combination with resin parts (P.41)

Lubricants (P.42, 43)

Application conditions table: Use as a reference when determining the bearing type and specifications.

Use	Shaft diameter	ϕ	mm (tolerance μm)	Accuracy (roundness μm , surface roughness μm)	Material ()
	Housing inner diameter	ϕ	mm (tolerance μm)	Accuracy (roundness μm , surface roughness μm)	Material ()
	Housing outer diameter	ϕ	mm		
	Bearing span		mm		
Rotation specification	Rotating ring	<input type="checkbox"/> Inner ring rotation <input type="checkbox"/> Outer ring rotation			
	Operating conditions	<input type="checkbox"/> Continuous min^{-1} (rpm)			
		<input type="checkbox"/> Intermittent			
		<input type="checkbox"/> Round trip			
Usage environment	Storage temperature and humidity	$^{\circ}\text{C}$	%RH		
	Environmental temperature and humidity	$^{\circ}\text{C}$	%RH		
	Bearing temperature	$^{\circ}\text{C}$			
Load	Radial direction	N (kgf)			
	Axial direction	N (kgf) (preload)		N (kgf)	
	Preload method	<input type="checkbox"/> Constant pressure <input type="checkbox"/> Fixed position <input type="checkbox"/> Front <input type="checkbox"/> Back			
	<input type="checkbox"/> Repeat <input type="checkbox"/> Vibration <input type="checkbox"/> Shock				
Conditions:					
Torque	<input type="checkbox"/> Starting torque <input type="checkbox"/> Rotating torque		$\text{mN}\cdot\text{m}$ (gf·cm)		
	Conditions:				
Sound and noise	Characteristics				
Other	Corrosion resistance, chemical resistance, magnetism, food safety				

1-4 Selecting a Bearing

② Application Structure, Required Performance, Environment

Review the dimensions of the location where the bearing is to be mounted, the expected performance of the bearing, the operating environment and conditions. In recent years, the size of equipment has been reduced, and there are many cases where there are restrictions on the structure. However, in order to maintain the required performance for a long period of time, it is recommended to provide as much space as possible.

It is also important to take market factors into account for selecting the bearing part number and specification.

- **Application structure and functions**
Determine the size envelope for the bearing by reviewing the structure and function of the application. Take the dimensions of the inner diameter, outer diameter, and width into consideration when choosing a bearing size.
- **Operating environment (temperature, humidity, vibration, dust, etc.)**
The bearing material, retainer, lubricant, etc. are determined from the upper and lower limits of the assumed environmental temperature and humidity. The vibration conditions are taken into consideration when determining preload, lubricant, etc. The cleanliness of the system influences the selection of shield or seal type. Depending on the operating conditions, bearing temperature is occasionally higher than ambient temperature.
- **Load**
The dimension (size) of the bearing is selected based on the magnitude, position, and direction of loads applied to the bearing. It is necessary to review the structure of the equipment to determine if excessive loads would be applied to the bearing. If so, select a larger size bearing or reduce the loads.
- **Materials and dimensions of shaft and housing**
The dimensions and tolerances of the bore diameter, outer diameter and width of the bearing are determined based on the dimensions and materials of the shaft and housing. Temperature changes can affect the bearing internal clearance if there are differences in linear expansion coefficients of the shaft, housing, and bearing materials.
- **Rotational speed, rotation precision, rotating ring**
The bearing's dimensional tolerances, retainers, clearances, preloads, lubricants, etc. are determined based on rotational speed, rotation precision, rotation conditions (continuous / intermittent / reciprocating rotation, inner ring / outer ring rotation).
- **Torque**
There are two types of torque: starting torque and rotating torque.
In particular, when there is a low torque requirement it is necessary to consider the type of lubricant, the fill amount and the retainer.
- **Noise**
When an application is noise sensitive, the acoustic properties of bearing components and lubricants need to be considered. It is also necessary to review other conditions around the bearing, such as the preload, imbalance and resonance of the rotor during operation of the bearing.
- **Life**
The service life is defined in JIS B 1518, but it is not strictly defined elsewhere. Life is defined in various ways depending on the application and the degree of performance deterioration (sound, torque, runout, etc.) Requirements from each customer.
In general, life can be calculated as rating life (fatigue life of material), modified rating life, functional life (performance such as sound, torque and vibration) and lubricant life.
- **Restricted substances**
In recent years, various regulations have been established for the environment, health and safety. It is necessary to confirm if regulated substances are present. Substances that are harmful to the environment and humans are restricted.
- **Other special application conditions**
In certain applications, proper care must be taken into how the bearing is exposed to special operating conditions. Applications where chemicals, gases, salt water, etc. are present, where dust cannot be generated by the bearing, and where electricity could flow through the bearing are all examples of special operating

③ Material

Ball bearing performance is significantly influenced by the selection of the proper material for components such as balls, inner and outer rings.

Bearings are exposed to severe stress. The contact area of inner and outer rings, as well as the balls, are repeatedly exposed to stress exceeding 1,000 MPa. Material type, purity and hardness are important factors for long bearing life under repeated high stresses. High carbon chromium bearing steel and high corrosion-resistant martensitic stainless steels are used for raceway rings and balls in NMB products. High-carbon chromium bearing steel uses high-grade vacuum degassed high-carbon chromium bearing steel (JIS G 4805 SUJ 2, AISI / SAE E52100) or equivalent material. With proper heat treatment, they have high load capacity, longer life and low noise levels. MinebeaMitsumi developed stainless steel "DD400" material. The hardness of DD400 after heat treatment is higher than that of SUS440C. The DD400 material also has excellent service life and load resistance.

The noise level of DD400 material is close to that of chromium steel because the carbon is dispersed spherically. From the results of tests based on ASTM-A380, the corrosion resistance of DD400 material is equal to SUS440C.

To meet longer life and low noise level requirements, ball bearings with ceramic balls are also available. When compared to the conventional chromium bearing steel balls, improved noise level and life can be achieved by using ceramic balls (Silicon Nitride) with the use of conventional chromium rings. The extremely low conductive characteristics (insulation properties) of silicon nitride protect bearings from electric corrosion, which is generated under a conductive environment.

Material properties

High carbon chromium bearing steel

Standard	Symbol	Chemical composition (wt%)						
		C	Si	Mn	P	S	Cr	Mo
JIS G 4805	SUJ 2	0.95~1.10	0.15~0.35	0.50 or less	0.025 or less	0.025 or less	1.30~1.60	-
AISI/SAE	E52100	0.98~1.10	0.15~0.35	0.25~0.45	0.025 or less	0.025 or less	1.30~1.60	-

Stainless steel

Standard	Symbol	Chemical composition (wt%)						
		C	Si	Mn	P	S	Cr	Mo
-	DD400	0.60~0.75	1.00 or less	1.00 or less	0.03 or less	0.02 or less	11.50~13.50	0.30 or less

1-4 Selecting a Bearing

④ Shield and Seal

Compared to the open type, the shielded and sealed bearing types provide better protection from contamination and grease leakage.

They are selected based on the application type and environment.

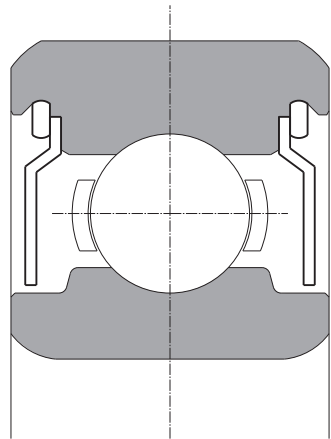

Steel plate shield (Fixed with snap ring)

NMB part number symbol: ZZ

The shield is secured to the outer ring with a snap ring.

No contact between shield bore and circumference of inner ring land.

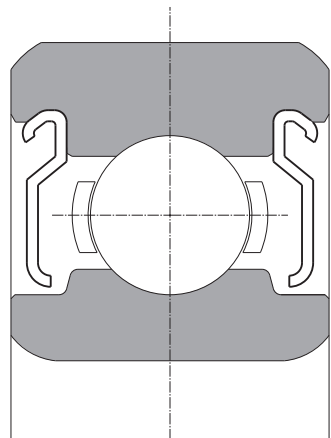

Steel plate shield

NMB part number symbol: KK or HH
JIS part number symbol: ZZ

The shield is secured directly to the outer ring.

No contact between shield bore and circumference of inner ring land.

SS

DD

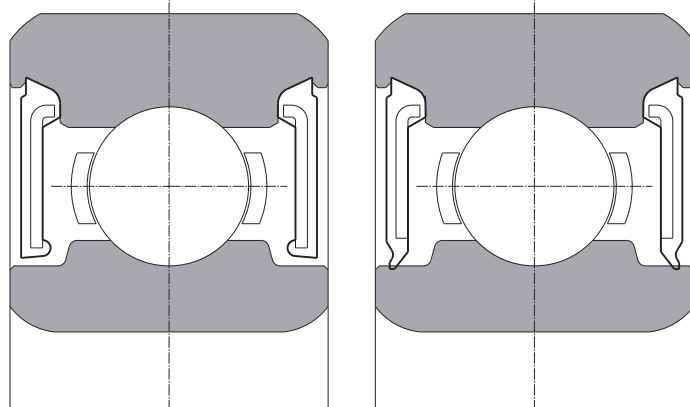

Rubber seal

Common symbol: SS and DD

Rubber seal with steel insert is secured directly to the outer ring.

The DD type seals contact the circumference of the inner ring, the SS type seals do not contact the inner ring.

DD has highly sealed, but torque to rotate is higher than non-contact enclosures.

⑤ Retainer

Retainers keep the balls separated and equally spaced. Retainer types are selected based on the bearing size, but can be selected based on the required performance.

Ribbon retainer

NMB part number symbol: R
JIS part number symbol: No display

Composed of two stamped steel plates

The balls are held between the two steel plates, and the tabs of the first steel plate are bent over the second to fasten them together. This is the most common retainer type.



Crown retainer

NMB part number symbol: H

Composed of a stamped steel part.

The small difference in inner and outer diameters of the retainer allows them to be used for thin type and miniature ball bearings.



Resin retainer

Common symbol: MN

Composed of molded or machined plastic.

Resin material includes polyamide, polyacetal and others.

Used for high speed rotation and low noise applications



1-4 Selecting a Bearing

⑥ Load rating and rating life

If high quality bearings are made with designs and materials based on bearing industry standards, such as JIS, the load rating and rating life can be calculated based on the specifications defined in JIS and ISO.

Life of ball bearing

The required life of a ball bearing depends on the application and requirements of the equipment. This is because there are such diverse applications, and the definitions of life also vary. Therefore, life needs to be defined based on the application and requirements.

There are several different types of life definitions: rating life, noise life, lubricant life, functional life, etc.

The noise life is considered when bearings become noisier than the originally set level. The lubricant life is considered as when lubricants lose their function due to degradation.

The performance life is considered when speed and runout go beyond the acceptable limits and no longer meets the application requirements.

This section provides an overview of the "rating life" and "modified rating life" of "single-row deep groove ball bearings" specified in **JIS B 1518**.

"Rating life" is the predicted life based on the basic dynamic radial load rating.

"Modified life" is the life rating in which 90% or greater reliability, fatigue limit load, lubricant contamination, and/or special operating conditions is achievable.

Basic dynamic radial load rating C_r

Defined as "constant static radial load such that the bearing theoretically endures the basic rating life of 1 million revolutions". The calculation method is shown in **JIS B 1518**. The basic dynamic radial load rating is described in the dimension table.

Dynamic equivalent radial load P_r

Defined as "a constant static radial load applied on the bearing in which similar life is achieved as under actual load conditions". Using the following formula and table, replace the combined radial load and axial load with static radial load.

$$P_r = X F_r + Y F_a$$

X, Y : Determined from the table below.

F_r : Radial load (N)

F_a : Axial load (N)

Axial load ratio $\frac{F_a}{F_r}$ $\frac{Z D_w^2}{(N)}$	e	$\frac{F_a}{F_r} \leq e$		$\frac{F_a}{F_r} > e$	
		X	Y	X	Y
0.172	0.19				2.30
0.354	0.22				1.99
0.689	0.26				1.71
1.03	0.28				1.55
1.38	0.30	1	0	0.56	1.45
2.07	0.34				1.31
3.45	0.38				1.15
5.17	0.42				1.04
6.89	0.44				1.00

Z : Number of balls

D_w : Ball diameter (mm)

Note 1: X, Y and e values not shown in the table are obtained by linear interpolation.

Note 2: As the formula for single-row bearings is used, the variable for the number of rows is excluded from the formula for calculating the axial load ratio specified in JIS.

Basic rating life L_{10}

Defined "rated life at 90% reliability under normal operating conditions." This is the "total rotational speed at which 90% of the bearings can rotate without causing material separation when the same group of bearings is operated under the same conditions."

It is calculated from the following formula based on **JIS B 1518**.

$$L_{10} = \left(\frac{C_r}{P_r} \right)^3$$

L_{10} : Basic rated life (10^6 rotations)
 C_r : Basic dynamic radial rated load (N)
 P_r : Dynamic equivalent radial load (N)

If the speed is constant, the life is usually expressed in hours. The relationship between basic rating life and life hours is as follows.

$$L_{10} = \left(\frac{10^6}{60 \cdot n} \right) \times \left(\frac{C_r}{P_r} \right)^3$$

L_{10} : time (h)
 n : rotational speed (min^{-1})

Modified rating life L_{nm}

If operating conditions are acceptable, a long life can be calculated with modified rating life as compared to the basic rating life. The life will be Reduced in poor operating conditions. **JIS B 1518:2013** defines a modified rating life where the fluctuation and interaction of each factor that affects bearing life is taken into consideration. The modified rating life of the reliability $n\%$ is expressed in the following formula.

$$L_{nm} = a_1 a_{iso} L_{10}$$

a_1 : Reliability coefficient
 a_{iso} : Life correction factor
 L_{10} : Basic rated life

Reliability factor a_1

The coefficients range from 90% to 99.95% reliability. See the table below.

Reliability (%)	L_{nm}	a_1
90	L_{10m}	1
95	L_{5m}	0.64
96	L_{4m}	0.55
97	L_{3m}	0.47
98	L_{2m}	0.37
99	L_{1m}	0.25
99.2	$L_{0.8m}$	0.22
99.4	$L_{0.6m}$	0.19
99.6	$L_{0.4m}$	0.16
99.8	$L_{0.2m}$	0.12
99.9	$L_{0.1m}$	0.093
99.92	$L_{0.08m}$	0.087
99.94	$L_{0.06m}$	0.080
99.95	$L_{0.05m}$	0.077

1-4 Selecting a Bearing

Life correction factor a_{ISO}

It is a coefficient derived from fatigue limit load, contamination coefficient, viscosity ratio, etc.

$$a_{ISO} = f \left(\frac{e_c c_u}{P}, \kappa \right)$$

- Fatigue load limit c_u
The load applied to the bearing that causes fatigue limit stress at the contact point of the maximum load of the track. (Fatigue limit stress is the maximum stress that does not cause fatigue in the bearing material)
- Pollution coefficient e_c
If the lubricant is contaminated with solid particles and the particles enter between the track and rolling elements, the track may become indented. In these indentations, the stress increases locally, leading to shortened life of the ball bearing. The pollution coefficient that takes into account this reduction in life. The following are excerpts from **JIS B 1518:2013** as indicators.

Index of pollution coefficient e_c

Pollution level	e_c
Extremely high cleanliness	1
High cleanliness	0.8~0.6
Standard cleanliness	0.6~0.5
Mild pollution	0.5~0.3
Normal pollution	0.3~0.1
Severe pollution	0.1~0
Extreme pollution	0

- Viscosity ratio κ
Indicates the separation of the rolling contact surface of the lubricant, and is the ratio of the kinematic viscosity of the oil at the actual operating temperature to the reference kinematic viscosity.

Note: There are various restrictions when calculating the modified rating life, and there are concerns about how appropriate it is for applications using miniature size bearings. It may be necessary to confirm complicated any application conditions that involve many factors such as the design, intended use and usage environment of the device. Therefore, be sure to consider the validity of the calculation result with sufficient evaluation and verification.

The basic static radial load rating and static equivalent radial load of rolling ball bearings are specified in JIS B 1519 "Calculation method of static load rating of rolling ball bearings".

Basic static radial load rating C_{or}

Defined as "the static load at which the calculated contact stress at the contact center between the ball receiving the maximum load and the track is 4,200 MPa." The permanent deformation of the ball and raceway as a result of this contact stress is approximately 0.0001 times the diameter of the ball. The basic static radial load rating is described in the dimension table.

Static equivalent radial load P_{or}

Defined as "the static radial load that generates the same contact stress as that generated under actual load conditions at the center of the contact portion between the ball receiving the maximum load and the track."
Take the larger value obtained from the following equation.

$$P_{or} = X_o F_r Y_o F_a$$

$$P_{or} = F_r$$

X_o, Y_o : according to JIS B 1519
Coefficient of deep groove ball bearing $X_o=0.6$
 $Y_o=0.5$

F_r : Radial load (N)

F_a : Axial load (N)

1-4 Selecting a Bearing

⑦ Tolerance and precision grade

Rolling ball bearings have classes, and JIS and ABMA specify tolerances and tolerance values for each class.

MinebeaMitsumi's products are based on JIS B 1514-1, -3, ABMA 12.2 and 20.

The main symbols used in the specification are as follows.

Tolerance and tolerance value

■ Dimensions

d : Nominal bore diameter

D : Nominal outer diameter

D_1 : Nominal outer ring flange outer diameter

B : Nominal inner ring width

C : Nominal outer ring width

r : Nominal chamfer dimensions of inner ring or outer ring

■ Dimensional Differences

Δd_s : Dimensional difference of actual bore diameter

Δd_{mp} : Dimensional difference of average bore diameter in the plane

Δd_m : Dimensional difference of average bore diameter

ΔD_s : Dimensional difference of actual outer diameter

ΔD_{mp} : Dimensional difference of average outer diameter in the plane

ΔD_m : Dimensional difference of average outer diameter

ΔB_s : Dimensional difference of actual inner ring width

ΔC_s : Dimensional difference of actual outer ring width

ΔD_{1s} : Dimensional difference of actual outer ring flange outer diameter

ΔC_{1s} : Dimensional difference of actual outer ring flange width

■ Chamfer

r_s : Actual chamfer dimensions of inner ring and outer ring

$r_{s \min}$: Minimum value of r_s

$r_{s \max}$: Maximum value of r_s

■ Inequality of Dimensions

V_{Bs} : Inequality of inner ring width

V_{Cs} : Inequality of outer ring width

V_{C1s} : Inequality of flanged outer ring width

■ Rotation Precision

$K_{ia} (K_i)$: Radial runout of inner ring

$S_{ia} (S_i)$: Axial runout of inner ring

$S_d (S_{di})$: Perpendicularity of inner ring side surface with respect to the inner diameter axis

$K_{ea} (K_e)$: Radial runout of outer ring

$S_{ea} (S_e)$: Axial runout of outer ring

$S_D (S_{D})$: Perpendicularity of outer ring outer diameter surface with respect to the side surface

S_{D1} : Perpendicularity of outer ring outer diameter surface to flange back

S_{eal} : Axial runout of outer ring flange back surface

Remark () is defined by ABMA.

Above is only for radial ball bearing.

Excerpt from JIS B 1514-1

Inner ring tolerance and tolerance value $d \leq 18$ mm

(Unit: μm)

Grade	Dimensional difference				Radial runout	Perpendicularity	Axial runout	Dimensional difference of width		Inequality of width
	Δd_{mp}		Δd_s		K_{ia}	S_d	S_{ia}	ΔB_s		V_{Bs}
	Upper	Bottom	Upper	Bottom	MAX	MAX	MAX	Upper	Bottom	MAX
Grade 0	0	-8	-	-	10	-	-	0	-40 ¹ -120	12 ¹ 15 ² 20
Grade 6	0	-7	-	-	5 ¹ 6 ² 7	-	-	0	-40 ¹ -120	12 ¹ 15 ² 20
Grade 5	0	-5	-	-	4	7	7	0	-40 ² -80	5
Grade 4	0	-4	0	-4	2.5	3	3	0	-40 ² -80	2.5
Grade 2	0	-2.5	0	-2.5	1.5	1.5	1.5	0	-40 ² -80	1.5

*1 Applicable to those with inner diameter of 2.5 mm or less. *2 Applicable to those with inner diameter of 10mm or less.

Outer ring tolerance and tolerance value $D \leq 30$ mm

(Unit: μm)

Grade	Dimensional difference				Radial runout	Perpendicularity	Axial runout	Dimensional difference of width		Inequality of width
	ΔD_{mp}		ΔD_s		K_{ea}	S_D	S_{ea}	ΔC_s		V_{Cs}
	Upper	Bottom	Upper	Bottom	MAX	MAX	MAX	Upper	Bottom	MAX
Grade 0	0	-8 ¹ -9	-	-	15	-	-	0	-40 ² -120	12 ² 15 ³ 20
Grade 6	0	-7 ¹ -8	-	-	8 ¹ 9	-	-	0	-40 ² -120	12 ² 15 ³ 20
Grade 5	0	-5 ¹ -6	-	-	5 ¹ 6	8	8	0	-40 ³ -80 ⁴	5
Grade 4	0	-4 ¹ -5	0	-4 ¹ -5	3 ¹ 4	4	4	0	-40 ³ -80 ⁴	2.5
Grade 2	0	-2.5 ¹ -4	0	-2.5 ¹ -4	1.5 ¹ 2.5	1.5	1.5 ¹ 2.5	0	-40 ³ -80 ⁴	1.5

*1 Applicable to those with outer diameter of 18 mm or less. *2 Applicable to those with inner diameter of 2.5 mm or less. *3 Applicable to those with inner diameter of 10 mm or less. *4 Applicable to those with inner diameter of 18 mm or less.

Tolerance of outer ring flange outer diameter (Unit: μm)

D_1		Non-positioning flange	
mm		ΔD_{1s}	
Over	Incl.	Upper	Bottom
10	18	+220	-36
18	30	+270	-43
		+330	-52

Remarks Contact us when using the flange outer diameter surface for positioning.

Tolerance and tolerance value of flange width and tolerance value of flange-related rotation precision

(Unit: μm)

D		Grade 0, Grade 6		Grade 5, Grade 4, Grade 2		Grade 0, Grade 6		Grade 5	Grade 4	Grade 2
mm		ΔC_{1s}				V_{C1s}				
Over	Incl.	Upper	Bottom	Upper	Bottom	MAX				
2.5 ¹	30	0	-40 ² -120	0	-40 ³ -80	12 ² 15 ³ 20	5	2.5	1.5	
D		Grade 5	Grade 4	Grade 2	Grade 5	Grade 4	Grade 2			
mm		S_{D1}			S_{eal}					
Over	Incl.	MAX			MAX					
2.5 ¹	18	8	4	1.5	11	7	3			
18	30	8	4	1.5	11	7	4			

*1 Outer diameter 2.5 mm is included in this dimension division. *2 Applicable to those with inner diameter of 2.5 mm or less. *3 Applicable to those with inner diameter of 10mm or less.

1-4 Selecting a Bearing

⑦ Tolerance and precision grade

Excerpt from ABMA 20

Inner ring tolerance and tolerance value $d \leq 18$ mm

(Unit: μm)

Grade ABEC	Δ_{dmp}		K_{ia}	S_{ia}	Δ_{Bs}		V_{Bs}
	Upper	Bottom	MAX	MAX	Upper	Bottom	MAX
1	0	-8	10	15 ^{*1} 20	0 0	- 40 ^{*1} -120	12 ^{*1} 15 ^{*2} 20

*1 Applicable to those with inner diameter of 0.6 mm or more, 2.5 mm or less.
*2 Applicable to those with inner diameter of 10 mm or less.

Outer ring tolerance and tolerance value $D \leq 30$ mm

(Unit: μm)

Grade ABEC	Δ_{Dmp}		K_{ea}	S_{ea}	Δ_{Cs}		V_{Cs}
	Upper	Bottom	MAX	MAX	Upper	Bottom	MAX
1	0	-8 ^{*1} -9	15	15 ^{*2} 20 ^{*1} 25	0	- 40 ^{*3} -120	12 ^{*3} 15 ^{*4} 20

*1 Applicable to those with outer diameter of 18 mm or less. *2 Applicable to those with outer diameter of 6mm or less.
*3 Applicable to those with inner diameter of 2.5 mm or less. *4 Applicable to those with inner diameter of 10mm or less.

Excerpt from ABMA 12.2

Inner ring tolerance and tolerance value $d \leq 18$ mm

(Unit: μm)

Grade ABEC	$\Delta_{\text{dmp}}^{\text{Note 1}}$		Δ_{ds}		K_{i}	S_{di}	S_{i}	Δ_{Bs}		V_{Bs}
	Upper	Bottom	Upper	Bottom	MAX	MAX	MAX	Upper	Bottom	MAX
3P	0	-5.1	+2.5	-7.6	5.1 ^{*1} 7.6	-	-	0	-127	-
5P	0	-5.1	0	-5.1	3.8	7.6	7.6	0	- 25.4	5.1
7P	0	-5.1	0	-5.1	2.5	2.5	2.5	0	- 25.4	2.5
9P	0	-2.5	0	-2.5	1.3	1.3	1.3	0	- 25.4	1.3

Note 1: Grade 3P is usually defined by Δ_{dm} .

*1 Applicable to those with inner diameter of 10 mm or less.

Outer ring tolerance and tolerance value $D \leq 30$ mm

(Unit: μm)

Grade ABEC	$\Delta_{\text{Dmp}}^{\text{Note 2}}$		Δ_{Ds}				K_{e}	S_{D}	S_{e}	Δ_{Cs}		V_{Cs}
			Open		Shield/seal							
	Upper	Bottom	Upper	Bottom	Upper	Bottom	MAX	MAX	MAX	Upper	Bottom	MAX
3P	0	-7.6	+2.5	-10.2	+5.1	-12.7	10.2	-	-	0	-127	-
5P	0	-5.1	0	- 5.1	+1	- 6.1	5.1	7.6	7.6	0	- 25.4	5.1
7P	0	-5.1	0	- 5.1	+1	- 6.1	3.8	3.8	5.1	0	- 25.4	2.5
9P	0	-2.5 ^{*1} -3.8	0	- 2.5 ^{*1} - 3.8	-	-	1.3 ^{*1} 2.5	1.3	1.3 ^{*1} 2.5	0	- 25.4	1.3

Note 2: Grade 3P is usually specified by Δ_{Dm} .

*1 Applicable to those with outer diameter of 18 mm or less.

Excerpt from JIS B 1514-3

Allowable limit value of chamfer dimension for radial ball bearings

(Unit: mm)

$r_{\text{s min}}$	d		$r_{\text{s max}}$	
	Over	Incl.	Radial Direction	Axial Direction ^{*1}
0.05	-	-	0.1	0.2
0.08	-	-	0.16	0.3
0.1	-	-	0.2	0.4
0.15	-	-	0.3	0.6
0.2	-	-	0.5	0.8
0.3	-	40	0.6	1
	40	-	0.8	1
0.6	-	40	1	2
	40	-	1.3	2
1	-	50	1.5	3
	50	-	1.9	3

*1 The value in the radial direction applies to those with width of 2 mm or less.

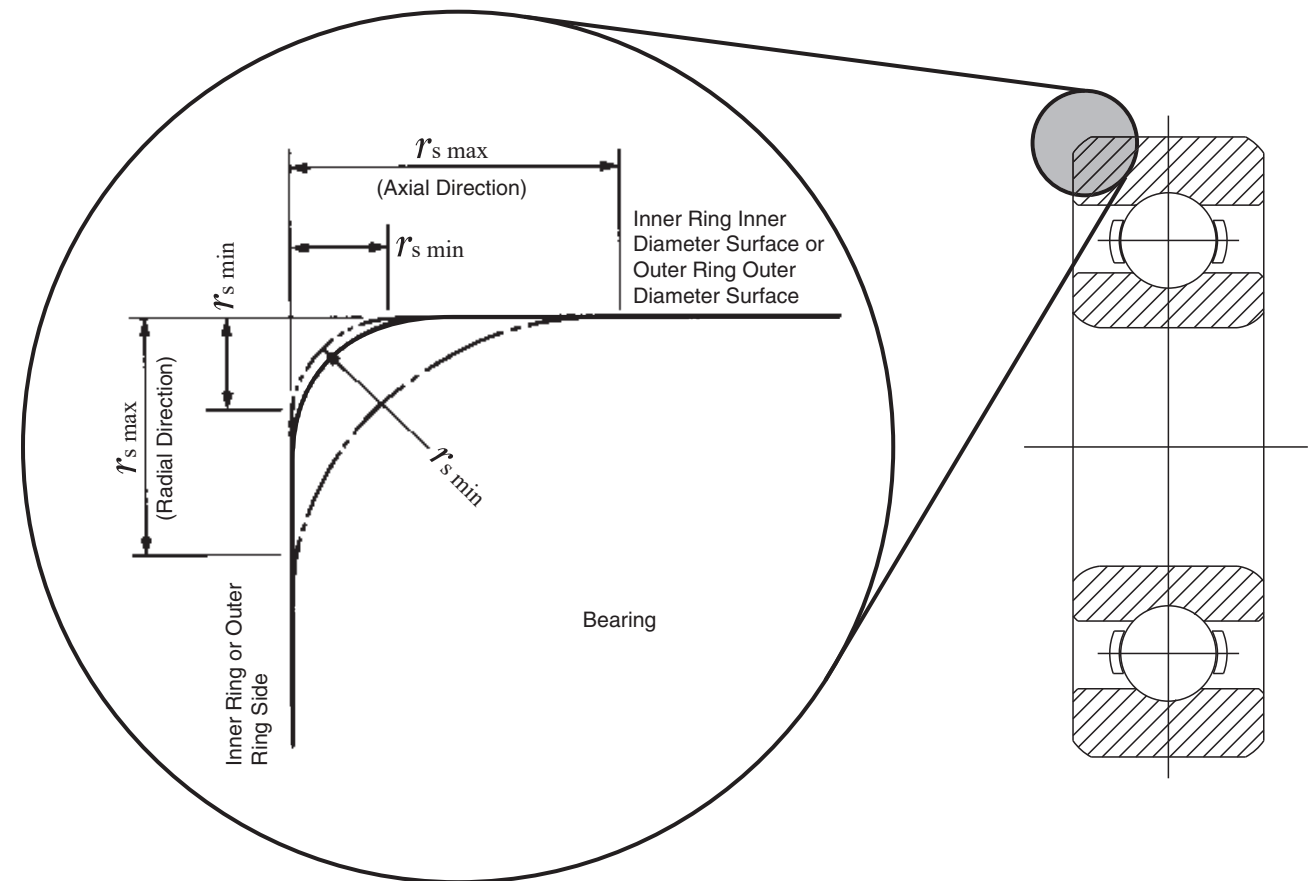

1-4 Selecting a Bearing

⑧ Measurement Methods

The general principles for verifying the dimensions and runout of rolling ball bearings are specified in JIS B 1515-2.

The overview of the method of measuring the actual dimensions and runout is shown below.

Dimensions related

- 1 Actual bore diameter (d_s) Fig. 8-1
- 2 Actual outer diameter (D_s) Fig. 8-2
- 3 Actual inner ring width (B_s) Fig. 8-3
- 4 Actual outer ring width (C_s) Fig. 8-4

Runout related

- 1 Perpendicularity of inner ring side surface with respect to the inner diameter axis (S_{di}) Fig. 8-5
- 2 Perpendicularity of outer ring outer diameter surface with respect to the side surface (S_{do}) Fig. 8-6
- 3 Radial runout of inner ring (K_{ria}) Fig. 8-7
- 4 Radial runout of outer ring (K_{rea}) Fig. 8-8
- 5 Axial runout of inner ring (S_{ia}) Fig. 8-9
- 6 Axial runout of outer ring (S_{ea}) Fig. 8-10

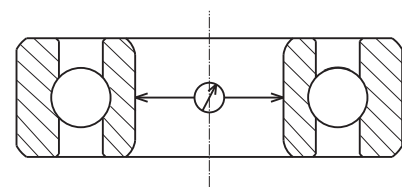

Measure at different angles in the radial plane.

Bore diameter (d_s) Fig. 8-1

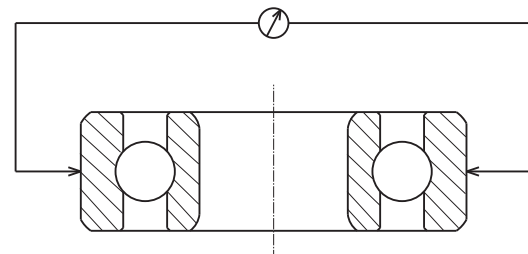

Measure at different angles in the radial plane.

Outer diameter (D_s) Fig. 8-2

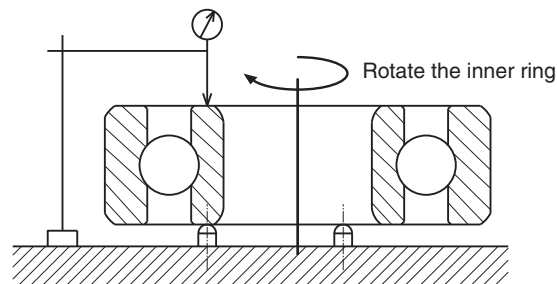

Turn the inner ring once and measure.

Inner ring width (B_s) Fig. 8-3

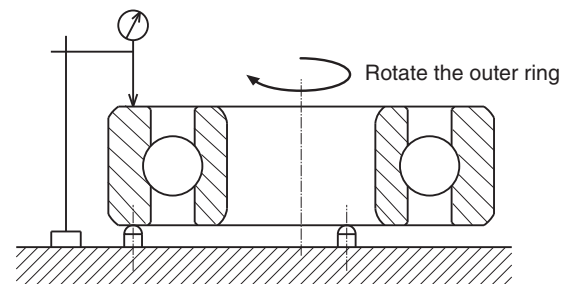

Turn the outer ring once and measure.

Outer ring width (C_s) Fig. 8-4

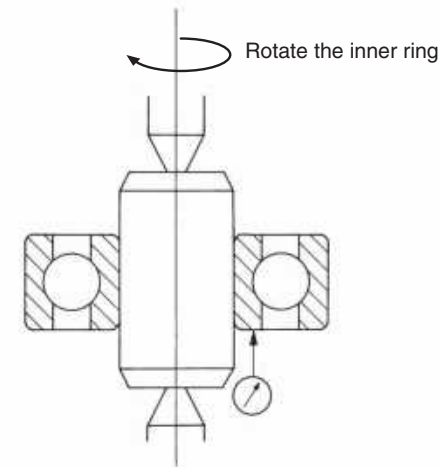

Read the indicator while rotating the inner ring once.

Perpendicularity of the inner ring side (S_{di}) Fig. 8-5

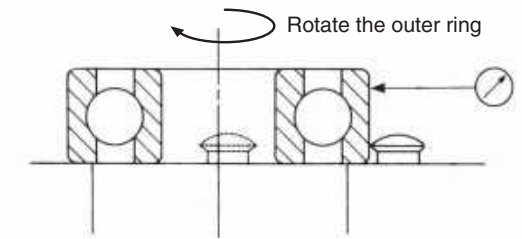

Read the indicator while rotating the outer ring once.

Perpendicularity of the outer ring outer diameter surface (S_{do}) Fig. 8-6

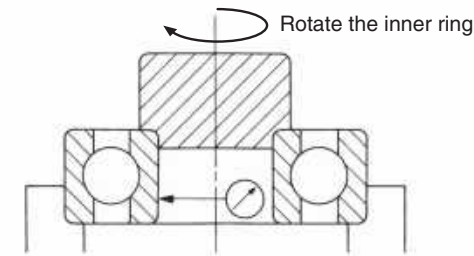

Apply a load to the inner ring and read the indicator while rotating once.

Radial runout of inner ring (K_{ria}) Fig. 8-7

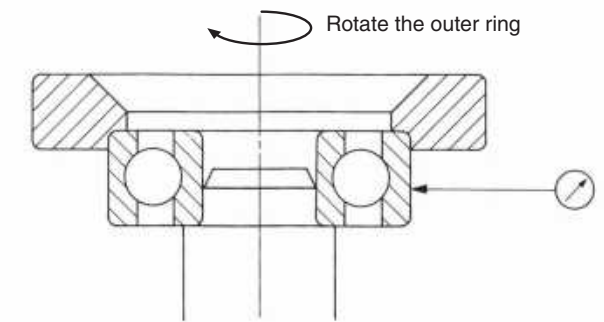

Apply a load to the outer ring and read the indicator while rotating once.

Radial runout of outer ring (K_{rea}) Fig. 8-8

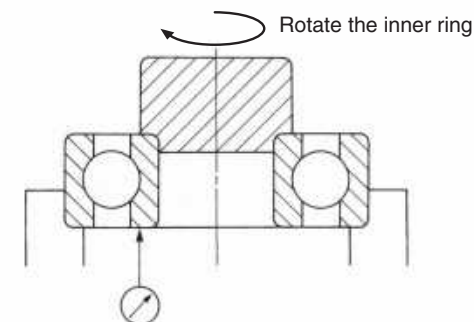

Apply a load to the inner ring and read the indicator while rotating once.

Axial runout of inner ring (S_{ia}) Fig. 8-9

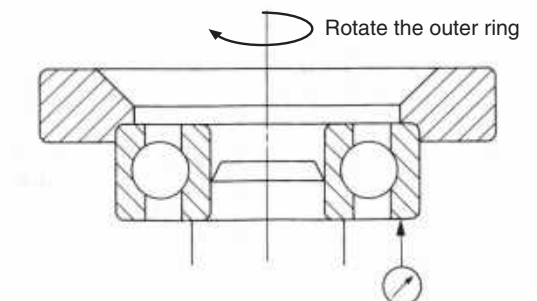

Apply a load to the outer ring and read the indicator while rotating once.

Axial runout of outer ring (S_{ea}) Fig. 8-10

1-4 Selecting a Bearing

⑨ Internal Clearance

The internal clearance of ball bearings influences performance factors, such as life, vibration, sound and heat generation.

It is important to select the appropriate internal clearance for the application.

Internal Clearance

There are three types of internal clearance: "radial clearance", "axial clearance" and "moment clearance".

- Radial clearance (Gr)

The displacement generated by moving the outer ring in the radial direction with the inner ring fixed (Fig. 9-1)

- Axial clearance (Ga)

The displacement generated by moving the inner ring in the axial direction with the outer ring fixed (Fig. 9-2)

- moment clearance (θ)

The angular displacement generated by tilting the inner ring in the axial direction with the outer ring fixed (Fig. 9-3)

Normally, the radial clearance is set as a standard value.

The standard values using NMB symbol and JIS symbol, are shown in the table below.

If the ball bearing is press fit with the shaft or housing, the internal clearance is reduced.

The internal clearance changes depending on the fitting and temperature conditions, so it is necessary to select the internal clearance with consideration of the actual usage conditions.

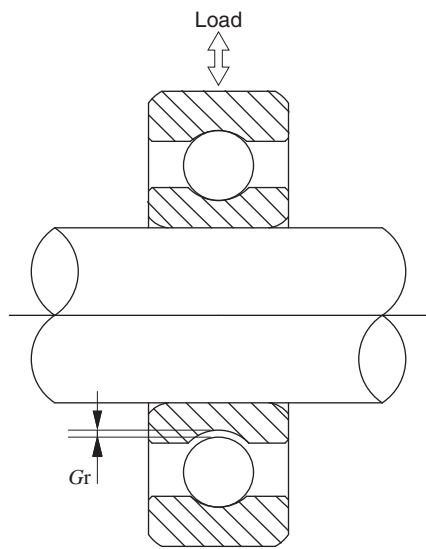

Radial Clearance (Gr)

Fig. 9-1

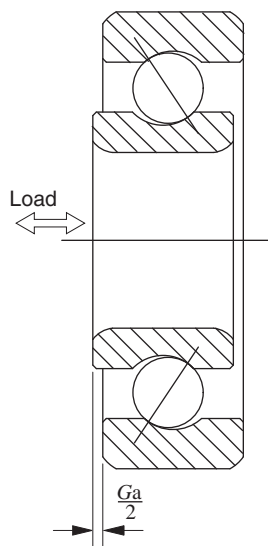

Axial Clearance (Ga)

Fig. 9-2

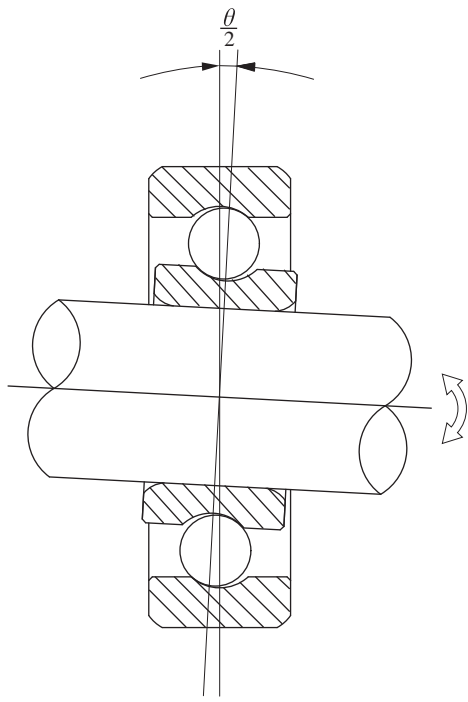

Corner Clearance (θ)

Fig. 9-3

Radial clearance of NMB numbering system

Clearance symbol	P13	P24	P25 (Standard)	P58
Clearance amount (μm)	2.5 ~ 7.5	5.0 ~ 10.0	5.0 ~ 12.5	12.5 ~ 20.0

Radial clearance of JIS numbering system

Clearance symbol	M2	M3 (Standard)	M4	M5
Clearance amount (μm)	3 ~ 8	5 ~ 10	8 ~ 13	13 ~ 20

Fits

When a ball bearing is used, it is always fitted to a shaft and/or a housing bore. Fit is a value of tightness between the shaft and bearing bore, as well as the fit between the housing and bearing outer diameter, when the bearing is installed. Fits are classified into clearance fit, intermediate fit, and interference fit.

Fits

The purpose of selecting the proper fitting condition is to suppress vibration during rotation, and to secure the inner ring and shaft of the ball bearing, and the housing and outer ring, to prevent slipping (creeping). When creeping occurs, abnormal heat generation and wear powder are generated due to sliding wear.

Abnormal heat generation accelerates the deterioration of grease, and wear particles enter the bearings, causing vibration and deterioration. It is necessary to choose a proper fit for each application because improper fits can not only degrade the bearing performance, but also they could cause seizure due to heat generation and premature failure.

In the case of interference fits, the interference causes a change in radial internal clearance. The change in radial clearance generated by interference can be calculated as shown below. (By TIMOSHENKO)

Decrease in internal clearance due to interference fit

- Interference fit of shaft and inner ring

The dotted line in Fig. 10-1 is the schematic before fitting, and the solid line is the schematic after fitting. Inner ring groove diameter d_2 increases by δ when press fit with interference i . That is, δ is the amount of radial clearance reduction due to fitting.

Press fit between shaft and inner ring:

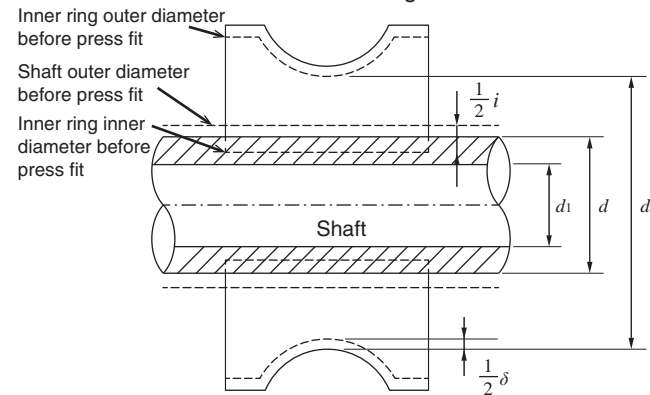

Fig. 10-1

$$\delta = \frac{2i(d_2/d)}{\left\{ \frac{(d_2/d)^2+1}{(d_2/d)^2-1} + \frac{1}{m_b} \right\} + \frac{E_b}{E_s} \left\{ \frac{(d/d_1)^2+1}{(d/d_1)^2-1} - \frac{1}{m_s} \right\}}$$

d : Nominal inner ring inner diameter, nominal shaft outer diameter
 d_1 : Shaft inner diameter (for solid shaft
 $\frac{(d/d_1)^2+1}{(d/d_1)^2-1} = 1$)
 d_2 : Inner ring groove diameter
 i : Interference ($i/2$ in radial direction)
 E_b : Young's modulus of inner ring (outer ring)
 E_s : Young's modulus of shaft
 m_b : Poisson number of inner ring (outer ring)
 m_s : Poisson number of shaft

- Interference fit of outer ring and housing

The dotted line in Fig. 10-2 is the schematic before fitting, and the solid line is the schematic after fitting. When press fitted with interference I , the outer ring groove diameter D_1 decreases by an amount Δ . That is, Δ is the amount of decrease in radial clearance due to fitting.

Press fit between outer ring and housing:

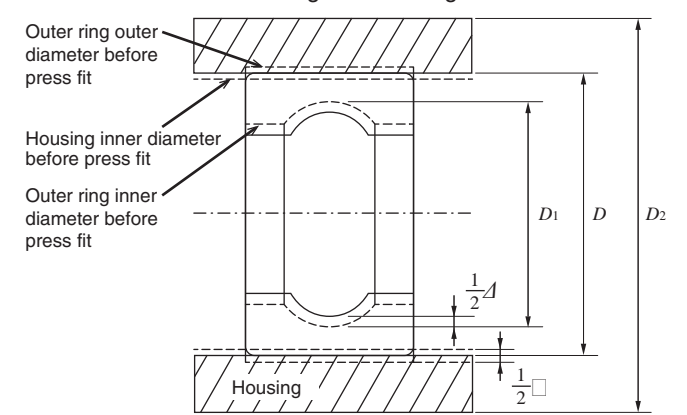

Fig. 10-2

$$\Delta = \frac{2I(D/D_1)}{\left\{ \frac{(D/D_1)^2+1}{(D/D_1)^2-1} + \frac{1}{m_b} \right\} + \frac{E_b}{E_h} \left\{ \frac{(D_2/D)^2+1}{(D_2/D)^2-1} + \frac{1}{m_h} \right\}}$$

D : Nominal outer ring outer diameter, E_b : Young's modulus of housing
 nominal housing inner diameter
 D_1 : Outer ring groove diameter
 D_2 : Housing outer diameter
 I : Interference ($I/2$ in radial direction)
 m_b : Poisson number of housing
 m_h : Poisson number of housing

Fixing the clearance fit with adhesive

When the bearing is fit to the shaft and housing with adhesive and without interference, it is necessary to select the proper clearance to enhance the effectiveness of the adhesive. It is recommended to consult with the adhesive manufacturer since the proper clearance depends on the type of adhesive.

Note that the roundness of the raceway ring may deteriorate due to the curing stress of the adhesive.

1-4 Selecting a Bearing

⑩ Fits

Excerpt from JIS B 0401-1

Dimensional tolerance of commonly used fitting holes (Unit: μm)

Classification of dimensions (mm)		G		H			JS			K			M			N		P
Over	Incl.	G7	H5	H6	H7	JS5	JS6	JS7	K5	K6	K7	M5	M6	M7	N6	N7	P7	
-	3	+12 + 2	+4 0	+6 0	+10 0	± 2	± 3	± 5	0 -4	0 -6	0 -10	- 2 - 6	- 2 - 8	- 2 -12	- 4 -10	- 4 -14	- 6 -16	
3	6	+16 + 4	+5 0	+8 0	+12 0	± 2.5	± 4	± 6	0 -5	+ 2 -6	+ 3 -9	- 3 - 8	- 1 - 9	0 -12	- 5 -13	- 4 -16	- 8 -20	
6	10	+20 + 5	+6 0	+9 0	+15 0	± 3	± 4.5	± 7.5	+1 -5	+ 2 -7	+ 5 -10	- 4 -10	- 3 -12	0 -15	- 7 -16	- 4 -19	- 9 -24	
10	18	+24 + 6	+8 0	+11 0	+18 0	± 4	± 5.5	± 9	+2 -6	+ 2 -9	+ 6 -12	- 4 -12	- 4 -15	0 -18	- 9 -20	- 5 -23	-11 -29	
18	30	+28 + 7	+9 0	+13 0	+21 0	± 4.5	± 6.5	± 10.5	+1 -8	+ 2 -11	+ 6 -15	- 5 -14	- 4 -17	0 -21	-11 -24	- 7 -28	-14 -35	

Dimensional tolerance of commonly used fitting shafts (Unit: μm)

Classification of dimensions (mm)		f	g		h			js			k			m		n	p	r
Over	Incl.	f6	g5	g6	h4	h5	h6	js4	js5	js6	k4	k5	k6	m5	m6	n6	p6	r6
-	3	- 6 -12	- 2 - 6	- 2 - 8	0 -3	0 -4	0 -6	± 1.5	± 2	± 3	+3 0	+4 0	+ 6 0	+ 6 + 2	+ 8 + 2	+10 + 4	+12 + 6	+16 +10
3	6	-10 -18	- 4 - 9	- 4 -12	0 -4	0 -5	0 -8	± 2	± 2.5	± 4	+5 +1	+6 +1	+ 9 + 1	+ 9 + 4	+12 + 4	+16 + 8	+20 +12	+23 +15
6	10	-13 -22	- 5 -11	- 5 -14	0 -4	0 -6	0 -9	± 2	± 3	± 4.5	+5 +1	+7 +1	+10 + 1	+12 + 6	+15 + 6	+19 +10	+24 +15	+28 +19

Excerpt from JIS B 1566

Fitting of radial bearing to inner ring^{*1}

Bearing grade	Inner ring rotational load or indefinite directional load						Inner ring static load			
	Shaft tolerance class ^{*2}									
Grade 0, Grade 6	r6	p6	n6	m6 m5	k6 k5	js6 js5	h5	h6 h5	g6 g5	f6
Grade 5	-	-	-	m5	k4	js4	h4	h5	-	-
Fits	Interference fit					Intermediate fit			Clearance fit	

Fitting of radial bearing to outer ring^{*3}

Bearing grade	Outer ring static load			Indeterminate direction load or rotating outer ring load						
	Hole tolerance class ^{*2}									
Grade 0, Grade 6	G7	H7 H6	JS7 JS6	-	JS7 JS6	K7 K6	M7 M6	N7 N6	P7	
Grade 5	-	H5	JS5	K5	-	K5	M5	-	-	
Fits	Clearance fit			Intermediate fit					Interference fit	

*1 Tolerance of bearing bore is based on JIS B 1514-1. *2 Symbol of tolerance zone class is based on JIS B 0401. *3 Tolerance of bearing outer diameter is based on JIS B 1514-1.

Definitions

- Rotating inner ring load** : The line of action of the load is rotating in relation to the inner ring of the bearing.
- Stationary inner ring load** : The line of action of the load does not rotate in relation to the inner ring of the bearing.
- Stationary outer ring load** : The line of action of the load does not rotate in relation to the outer ring of the bearing.
- Rotating outer ring load** : The line of action of the load is rotating in relation to the outer ring of the bearing.
- Indeterminate direction load** : The direction of the load cannot be determined.

⑪ Designs of Shaft and Housing

For ball bearing applications, the shaft and housing dimensions and precision should be carefully designed to optimize the performance of the bearing.

Shaft and housing

- Finishing accuracy of shaft and housing**
When the bearings are installed, roundness of the bearings can be degraded if the accuracy and surface roughness of the shaft and housing are not at satisfactory levels.
- Fillet radii of corners of shaft and housing**
The side faces of the shafts and housing (areas contacting the bearing's side face) should be perpendicular to the shaft center line and fitting surface. Also, the maximum permissible radius of the fillet ($r_{as\ max}$) must be smaller than the minimum permissible chamfer dimension of the bearing.
- Shoulder height**

The shoulder height (h) of the shaft and housing must be larger than the minimum allowable chamfer dimension of the bearing, and it should be a height that firmly contacts the end faces of the outer ring and inner ring. As a guide, the minimum value of shoulder height (h) is about 4 times the minimum allowable chamfer dimension of the bearing. Refer to Fig. 11-1 and the table on the right for dimensional relationship.

Excerpt from JIS B 1566

(Unit: mm)

Inner ring or outer ring's chamfer dimensions	Shaft or housing		
	Corner radius	For general use ^{*1}	For special use ^{*2}
$r_{s\ min}$	$r_{as\ max}$	h (minimum)	
0.05 ^{*3}	0.05	0.2	0.2
0.08 ^{*3}	0.08	0.3	0.3
0.1	0.1	0.4	0.4
0.15	0.15	0.6	0.6
0.2	0.2	0.8	0.8
0.3	0.3	1.25	1

* 1 When a large axial load is applied, a shoulder height larger than this value is required.
* 2 Used when the axial load is small.
* 3 Not specified in JIS B 1566.

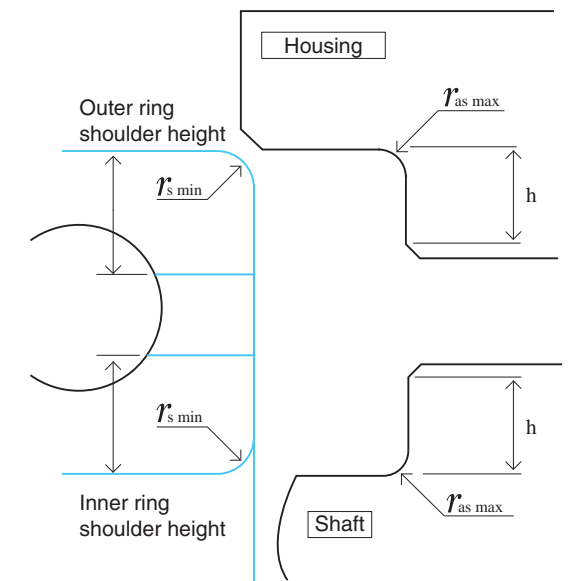

Fig. 11-1

1-4 Selecting a Bearing

12 Preload

The purpose of applying a preload to a ball bearing is to improve the runout precision of the rotating shaft, and to reduce vibration and noise. However, if the preload amount and preload method are not properly selected, bearing performance such as life, noise and heat generation may be degraded, and/or vibration may increase. Therefore, it is important to select the proper amount of preload and method for each application.

The purpose of preload

If there is any internal clearance in a ball bearing, the balls will have more play, the stiffness of the ball bearing will be minimal, and the vibration levels of the shaft will increase. Therefore, internal clearance needs to be adjusted to zero by applying an axial load (Fa) as shown in the figure 12-1. This load, applied in the axial direction, is called the "preload," and reduces vibration and noise. It is not enough to apply the appropriate preload method; the magnitude of preload should also be selected carefully to the required performance of the ball bearing. If the preload is applied excessively, the bearing stiffness will increase. However, bearing life will be shorter, and bearing noise will increase as well. If the applied preload is insufficient, fretting damage could occur due to vibration and low bearing stiffness. Therefore, selecting the appropriate preload is an important factor when considering the performance of a ball bearing.

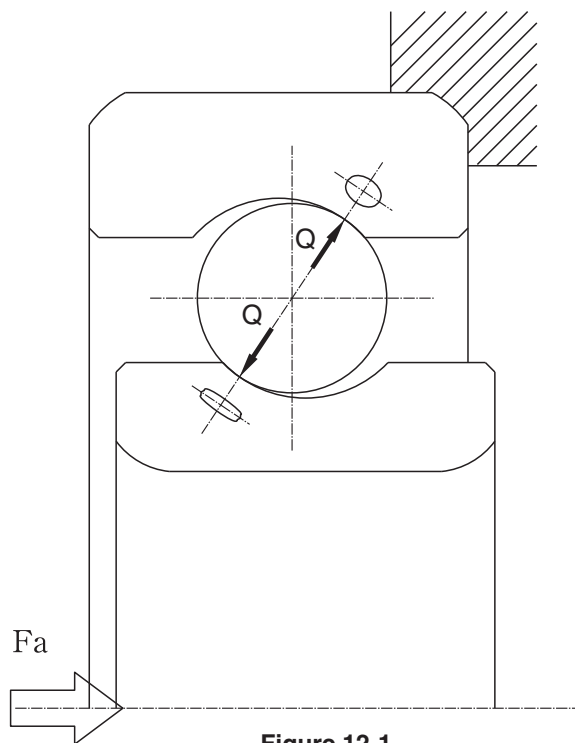

Figure 12-1

Optimum preload

If the preload is the dominant load applied to the bearing, MinebeaMitsumi recommends an optimum preload based on the "surface stress" calculation, which focuses on noise life.

When the preload (Fa) is applied to the ball bearing, a small contact ellipse is generated as a result of elastic deformation of the contact areas between balls and raceways. The surface stress is calculated by dividing the loads (rolling element load: Q) which are generated in the perpendicular direction at the contacts between the balls and raceways, by the surface areas (S) of the contact ellipses.

In figure 12-1, the contact ellipse area (S) between the balls and raceways is formulated as

$S = \pi ab$ (mm²), where the ratio of circumference is π , the major axis is a and the minor axis is b.

Also, if the average surface stress is P, $P = Q/S$ (MPa).

See below for the noise life guideline.

Over 10,000 hours noise life requirement

The specific preload should not generate an average surface contact stress (P) higher than 800MPa.

5,000 - 10,000 hours noise life requirement (general products)

The specific preload should be generating an average surface contact stress (P) of roughly 1000MPa.

Less than 5,000 hours noise life requirement (critical stiffness application)

The specific preload should be generating an average surface contact stress (P) of roughly 1500MPa.

Simple calculation of the preloads by using dynamic load rating (Cr)

Over 10,000 hours noise life requirement : $0.5/100 \cdot Cr - 1/100 \cdot Cr$

5,000 - 10,000 hours noise life requirement : $1/100 \cdot Cr - 1.5/100 \cdot Cr$

Less than 5,000 hours noise life requirement : $1.5/100 \cdot Cr - 2/100 \cdot Cr$

Maximum permissible load

In the case of high carbon chromium bearing steel, it is said that if the average surface stress exceeds 2,700 MPa, it will enter the plastic deformation region. Even if the loads are applied for very short time, the loads should not generate more than 2700MPa of average surface stress. From experience, we recommend applying loads which do not generate more than 1600MPa of average surface stress.

Besides preload, other types of loads should also be considered because they could generate surface stress.

Preload and stiffness

There are two methods of preloading: "fixed position preload" (Figure 12-2) and "constant pressure preload" (Figure 12-3).

Fixed position preload

This is a method for applying preload based on the positional relationship between parts. The advantages are simplicity and high stiffness of the components. However, expansion and shrinkage of the components due to temperature change occasionally can cause changes in preload. The components could also wear out, and eventually the preloads could be reduced.

Constant pressure preload

Constant pressure preload can be applied by using a coil spring, a spring wave washer, and so on. An advantage of spring preload is a stable preload despite temperature variation. The disadvantages are complexity and low stiffness.

The preload can be applied in two directions: Duplex face to face (DF) (Figure 12-4) and duplex back to back (DB) (Figure 12-5).

Duplex face to face (DF)

Since the intersection of the contact angles is inward, it has the disadvantage of poor rigidity, but the tolerance for mounting errors will be large. Duplex face to face may be selected in consideration of the structure of the application and the simplification of the assembly process.

Duplex back to back (DB)

The rigidity is high as the intersection of the contact angles is open outward. In order to improve rigidity, it is necessary to control the component precision at the same time.

Preload method

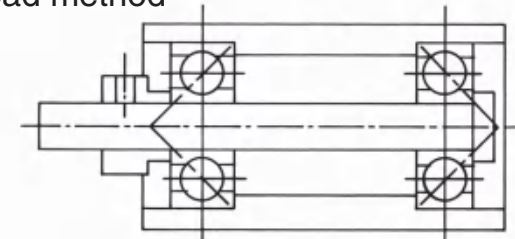

Figure 12-2 Fixed position preload

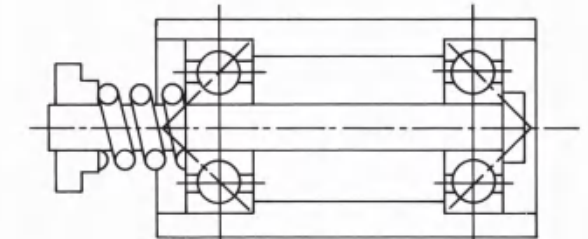

Figure 12-3 Constant pressure preload

Preload direction

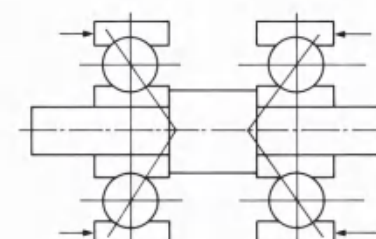

Figure 12-4 Duplex face to face (DF)

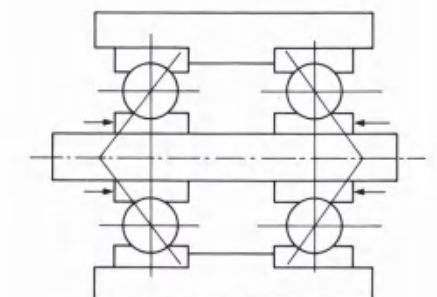

Figure 12-5 Duplex back to back (DB)

1-4 Selecting a Bearing

13 Displacement

When an external load is applied to the rolling ball bearing, deformation (displacement) occurs at the contact points between balls and raceways.

Radial displacement

As shown in Figure 13-1, when the radial load (F_r) is applied, the maximum load (Q) applied to the ball is

$$Q = \frac{5}{Z} F_r$$

Z : Number of balls

Radial displacement (δ) at the contact points between balls and raceways is

$$\delta = e_{\delta} \sqrt[3]{\sum p} Q^2$$

e_{δ} : Coefficient determined by relationship between balls and raceways

$\sum p$: Sum of principal curvatures of contact points

Since the ball is in contact with the inner and outer rings, the total displacement will be the sum of the displacements of both.

δ_r : Total radial displacement

δ_i : Radial displacement between balls and inner ring raceway

δ_e : Radial displacement between balls and outer ring raceway

Total displacement (δ_r) is represented as follows.

$$\delta_r = \delta_i + \delta_e$$

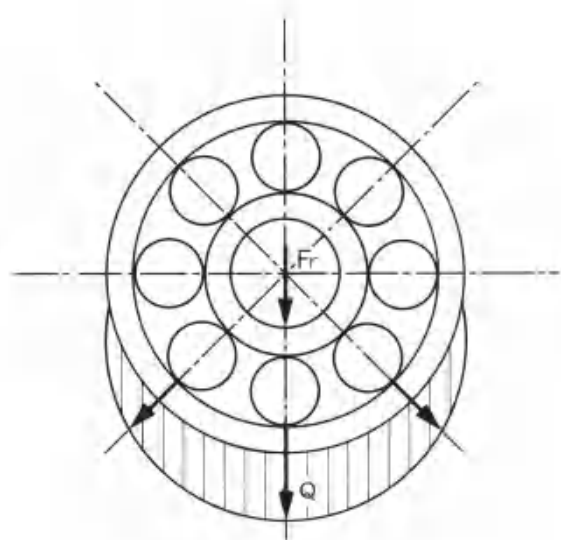

Figure 13-1

Axial displacement

the axial displacement (δ_a) when the axial load (F_a) is applied by the following method.

$$\delta_a = (r_i + r_e - D_w) (\sin \alpha - \sin \alpha_0) + c \left(\frac{F_a}{Z} \right)^{\frac{2}{3}} \left(\frac{\sin \alpha}{D_w} \right)^{\frac{1}{3}}$$

c : Contact elastic modulus

Relationship between initial contact angle (α_0) and contact angle (α)

When moving one of the raceway rings in the axial direction until clearance disappears, the initial contact angle shown in Figure 13-2 (α_0) is obtained as follows.

$$\alpha_0 = \cos^{-1} \left\{ 1 - \frac{G_r}{2(r_i + r_e - D_w)} \right\}$$

G_r : Radial clearance

r_i : Inner ring groove curvature radius

r_e : Outer ring groove curvature radius

D_w : Ball diameter

As shown in Figure 13-2, the relational expression between the contact angle (α) and initial contact angle (α_0) generated when a load (F_a) is applied in the axial direction from the initial contact state is as follows.

$$\frac{\cos \alpha_0}{\cos \alpha} = 1 + \frac{c \cdot D_w}{(r_i + r_e - D_w)} \left(\frac{F_a}{Z \cdot D_w^2 \cdot \sin \alpha} \right)^{\frac{2}{3}}$$

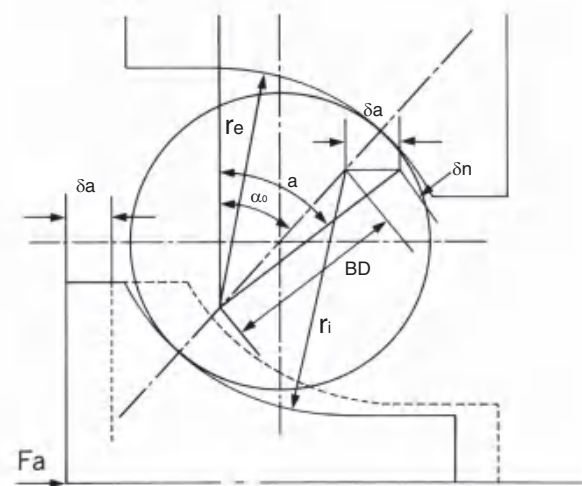

Figure 13-2

14 Torque

The torque of rolling ball bearings varies depending on the assembly method, the amount of preload, and the type and amount of lubricant. These need to be selected based on the required specification.

Torque

There are two basic kinds of torque: Starting torque and running torque.

(1) Starting torque

The torque required to rotate a non-rotating ball bearing. A ball bearing in the static state has the elastic contact deformation generated between the raceways and balls if the loads, like preload, are applied to the shaft. A force to overcome the elastic contact deformation is required to rotate the bearings. Also, a force to overcome the lubricant fill between the balls and raceways is required. These forces (resistance) are the starting torque.

(2) Running torque

In addition to the force required to stir lubricants by balls, raceways, and retainer, running torque includes friction between the balls and retainer, and the balls and raceways. The running torque has an impact on heat generation. In a motor application, bearing torque has an influence on the startup current, current rating, RPM rating, current fluctuation, and speed fluctuation.

The followings are the factors and solutions.

- Failure to reach speed

Some motors do not reach the designed nominal speed. Excessive amount of grease, grease churning, tight fit, and excessive preload can cause this problem.

- Excessive startup current

Grease fill amount, grease churning, preload, and fits are the possible factors to be considered in order to solve this problem.

- Speed fluctuation

Speed fluctuation is the phenomenon where the rotation speed fluctuates suddenly, and goes back to stable rotation after a while. This happens when grease caught between the balls and raceways loses its channel (wall), and running resistance changes momentarily. Torque is also affected. Decreasing the grease fill amount, changing the grease to higher channeling grease, or non churning type are the choices to make in order to prevent having this issue.

- RMP and running torque

Generally, torque increases as RPM increases. Preload and grease are selected based on the RPM.

- Grease fill amount and running torque

Generally, torque increases as the grease fill amount increases. Life could be adversely affected also if the grease fill amount is reduced only for the purpose of lowering the torque.

- Temperature and running torque

Generally, running torque increases as the temperature decreases. The reason for this is that the temperature reduction increases the viscosity of the base oil in the grease.

- Grease fill position and running torque

Running torque varies with different grease fill positions. For example, the torque fluctuates depending on whether or not the grease on the retainer is connected to the inner and outer raceways. The shear force of the grease also affects torque.

- Load and running torque

Once a load is applied to a ball bearing, both the starting torque and running torque change. For example, torque is higher when preload is applied as compared to when preload is not applied.

1-4 Selecting a Bearing

16 Noise

Noise level is checked by Anderon meter, which is explained below.
 * Anderon: It is a unit used to express the vibration unique to a bearing.

Anderon meter

Finished bearings are rotated in the Anderon meter, which evaluates the final rotational state.
 The inner ring is mounted on the spindle and rotated at 1,800 min⁻¹, preload is applied to the stationary outer ring, a velocity sensor is brought into contact with the outer circumference, and the mechanical vibration transmitted to the outer ring is extracted as an electrical signal to be evaluated. Since the inner ring is rotated by a high-precision spindle and vibration is detected directly from the outer ring, it is possible to detect small vibrations by eliminating external influences.
 The detected vibration is classified into three different frequency bands: L (Low band), M (Medium band) and H (High band), and the vibration is confirmed and evaluated for each frequency band.

Band	Frequency band (Hz)
L : Low Band	50 ~ 300
M : Medium Band	300 ~ 1800
H : High Band	1800 ~ 10000

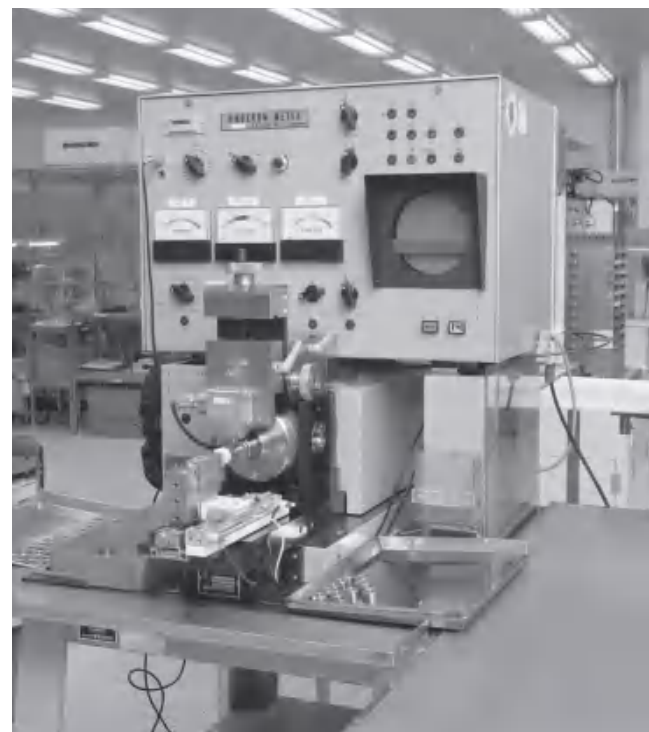

Anderon meter

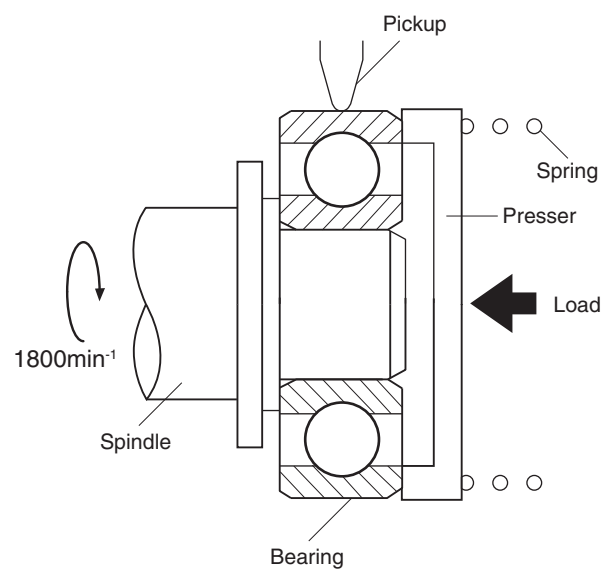

Schematic diagram of detector

17 Combination with Resin Parts

Resin materials may cause problems such as breakage and deterioration depending on the components of the oil used in the bearings.
 MinebeaMitsumi completes compatibility tests between resin materials and lubricants.

Chemical attack

If there is a resin material around the bearing, the resin material may deteriorate or break due to the lack of compatibility with the lubricant filled in the bearing or the rust-preventive oil applied to the outer periphery of the bearing. This phenomenon is called "chemical attack". In general, chemical attack tends to occur easily with non-crystalline resin, and tends not to occur with crystalline resin. This is probably because non-crystalline resin tends to penetrate lubricant between molecules and break intermolecular bonds more easily than crystalline resin. The resin material is selected in consideration of functionality, productivity and economics, so it may be difficult to only emphasize the countermeasures for chemical attack. Chemical attack tends to occur especially when the resin material is exposed to high temperatures while being subjected to physical stress, so measures such as stress mitigation and temperature reduction must be carefully considered.
 Ester-based lubricants, that are commonly used, easily penetrate into the resin and have the tendency to cause chemical attack. Lubricants that do not easily penetrate include those using synthetic hydrocarbon-based, fluorine-based, and silicone-based base oils.
 MinebeaMitsumi is developing synthetic hydrocarbon grease and oil that are less prone to chemical attack.

Stress on resin parts

The physical stress of resin parts includes those that remain inside during molding and those that are applied later in assembly. These stresses not only promote the chemical attack, but also contribute to bearing mounting errors and deformation of the bearings themselves, so thorough verification is required to confirm that the stress on the bearing (movable section) has been eliminated. In addition, it is necessary to pay attention to interference with other parts as secondary processing after molding and the force applied to a distant location may have an effect.

Weld line

Weld lines found in injection molded parts not only reduce the strength of resin parts, but also cause mounting errors and promote chemical attack due to penetration of lubricant. Care must be taken to ensure that there is no inappropriate weld line around the bearing.

1-4 Selecting a Bearing

18 Lubricants

Grease or oil is usually used to lubricate the bearing. In the case of miniature and small-diameter bearings, most are used for the life of the equipment without replacing the initially filled lubricant. Therefore, when selecting a lubricant, it is necessary to carefully consider the life, torque, rotating performance, noise level, etc.

Grease

Thickener is dispersed in base oil to make it semi-solid or solid. It consists of base oil, thickener and additives, and the characteristics are determined by the combination of these.

- Base oil
Base oils are roughly classified into mineral oil, synthetic oil and mixed oil.
- Thickener
Thickener is added to disperse in base oils to make them semi-solid (grease-like). It is an important substance in setting the properties and performance of grease.
Thickeners are broadly classified into soap using metallic soap (such as lithium) and non-soap (such as urea) that does not use metallic soap.
- Additive
Additive is utilized to improve the physical and chemical performance of grease. Additive types include antioxidant, rust inhibitor, corrosion inhibitor and extreme pressure additive.

Oil

Oils are roughly classified into mineral oil, synthetic oil and mixed oil. Since oil is fluid and only a small amount is applied to the bearing, it is possible to reduce torque, but the life needs to be examined. It is also used as a base oil for grease.

Lubricant type

Grease is broadly classified according to the thickener type, etc. as shown in Table 18-1.

The characteristics of typical grease are shown below.

- Lithium soap grease
Lithium grease provides excellent quietness and durability, and is the most widely used universal grease in general industries, automobiles and home appliances. A relatively low-cost grease.
- Urea grease
Urea grease has excellent heat resistance, high speed and water resistance, and is widely used in electrical components for automobiles, motors for vacuum cleaners and ventilation fans. In addition, there are greases that have excellent chemical attack resistance (resin cracking) when combined with synthetic oil.
- Fluorine grease
Fluorine grease has excellent chemical stability and is used in high-temperature environments such as around automobile engines. It is also used in vacuum environments. It is a very expensive grease.
- Conductive grease
Conductive grease has conductivity and can conduct electricity in bearings, and is used for copying machines and other devices that should not be electrified.

Grease filling amount

The standard grease fill amount for small-diameter and miniature rolling ball bearings is 30%. The fill amount is shown in the table on the right to adapt to the application.

Filling amount symbol	Filling amount
X	5~10%
L	10~15%
T	15~20%
No symbol (standard)	25~35%
H	40~50%
J	50~60%

Note

In recent years, as devices become smaller and lighter, resin materials are increasingly utilized where bearings are incorporated. Some resin materials have poor chemical compatibility with certain oil and grease, and may cause deterioration or breakage. When selecting a lubricant, it is necessary to carefully consider the operating environment. For details, refer to 2-10 Chemical Attack on P.47.

Table 18-1 Lubricant types

Name	Thickener	Base oil	Noise	Torque	High temperature	Low temperature	High speed	Resin degradation	Conductivity	Low dust	Price	Code	Characteristics	Base oil kinematic viscosity mm ² /s at 40°C Representing value	Mixing consistency Representing value	Operating temperature range
Lithium soap grease	LI soap	Ester, etc.	◎◎	◎	○	○	△	×	-	×	◎◎	LY121	General	24	250	-50~+150
			◎◎	◎◎	△	◎	△	×	-	×	◎	LY72	Low torque	16	275	-50~+130
Urea grease	Urea	Synthetic hydrocarbon	◎	○	◎	△	◎	○	-	○	◎◎	LY551	Heat resistance, high speed	48	235	-40~+200
		Ester	△	△	◎○	×	◎	×	-	-	△	LY706	Heat resistance	100	263	-40~+180
Fluorine grease	PTFE	Fluorine	-	△	◎◎◎	-	-	*	-	-	×	LY500	Heat resistance	190	280	-50~+260
			-	○	◎◎	○	△	*	-	-	×	LY586	Heat resistance	85	280	-65~+260
			-	○○	◎◎	◎	△	*	-	-	xx	LY699	Heat resistance, low torque	85	280	-50~+220
			-	△	◎◎◎	-	-	*	-	-	△	LY655	Heat resistance, low price	210	290	-40~+200
Conductive grease	Carbon	Synthetic hydrocarbon	×	-	◎	-	×	○	◎	-	△	LY727	Conductivity	148	235	-40~+125
		Fluorine	×	-	◎◎	-	×	○	◎	-	×	LY746	Conductivity, heat resistance	208	327	-50~+225
Oil	-	Ester	◎	◎◎◎	△	◎	△	×	-	×	○	LO1	Low torque	12	-	-57~+177
		Synthetic hydrocarbon	◎	◎◎◎	△	○	△	○	-	×	△	LY650	Resin resistance	32	-	-40~+130

Consult us for those with *.
 Note: The operating temperature range is the catalog value of the lubricant manufacturer and not the possible operating temperature range of the bearing. (The setting method differs depending on the manufacturer.)
 Remarks: Superior/inferior display mark: Superior ◎◎◎-◎◎-◎○-◎-○○-○-△-x-xx Inferior

1-5 Handling of a Bearing

Handling of a Bearing

If ball bearings were improperly assembled to either shafts or housings, the bearings could be damaged. This would shorten the life due to noise, vibration, and heat generation. Careful handling is also required during shipping and storing.

1 Notes on storage

Ball bearings undergo noise and visual inspections and delivered in a clean condition.

Care must also be taken to keep the product in a clean state during storage until use.

1-1 Dust must be avoided for bearings

If dust enters the ball bearing, it gets caught between the ball and raceway, increasing noise and decreasing durability.

Dust includes fine fibers, dust, paper, etc. and metal powder.

- Do not open unnecessarily
Open immediately before use.
- Repackage unused parts (fractions) after unpacking
Unused products should be sealed and not opened.
- Beware of dust during use
Even during use, cover bearings frequently to prevent dust from adhering.

1-2 Bearings easily rust

Many ball bearings use high carbon chromium bearing steel. One aspect of this material is that it easily rusts.

- Avoid places where there are large changes in temperature and humidity
Store indoors, avoiding places where there are large fluctuations in temperature and humidity, such as those exposed to outside air or direct sunlight.
- Do not place the packing box directly on the floor
Avoid placing it directly on the floor (ground, concrete, etc.).
Place the box on a pallet or shelf.
- Do not touch with bare hands
Use clean rubber gloves, finger cots, tweezers, etc., and avoid direct contact with bare hands. Care must be taken because skin oils often cause rust.

1-3 Bearings are vulnerable to impact

Ball bearings undergo brinelling when subjected to impact load.

Be especially careful when handling miniature bearings with low load capacity.

- Do not handle in rough manner
Do not drop or throw it from high places even in the packaged state.
Do not handle bearings roughly when moving them to a container to be stored.
Doing so may cause brinelling and denting of shield plate.
- Do not use dropped products
Do not use bearings that have been dropped on the floor.
Brinelling caused by drop impact may cause abnormal sound.

2 Notes on use and assembling

Improper use and incorporation of ball bearings may cause abnormal noise, vibration, runout and rotational issues. Keep the work environment clean and pay attention to parts and work management.

2-1 Do not process

Be sure to use the bearings as delivered.

- Disassembly and reassembly
Do not disassemble or reassemble the bearings.
Abnormal noise and rotation failure may occur due to ingress of dust or scratches.

2-2 Cleanliness

Pay attention to the cleanliness of bearings and mating components.

- Cleaning parts (Figure 19-1)
Clean the parts where the bearing is assembled, such as the shaft and housing.
Foreign matter adhering to the shaft or housing causes abnormal noise or misalignment (failure in assembly precision).

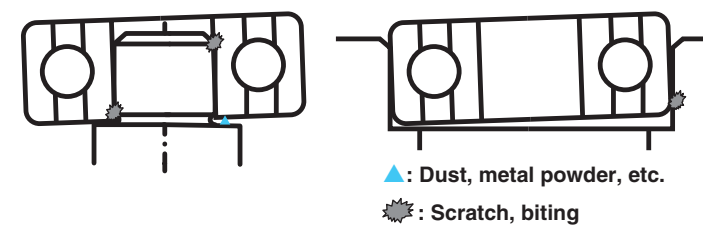

Figure 19-1 Misalignment due to foreign matter and scratch

2-3 Wiping off the oil

Before adhering, you may wipe off the rust-preventive oil applied to the outer and inner diameters of the bearing, but this may cause the solvent to penetrate the bearing, which may cause noise and rotation failure.

- Use a clean dust-proof cloth
Consider the frequency of use and keep it clean.
- Use minimal solvent
Normally, oil is wiped off with a cloth soaked with a solvent such as alcohol. In such case, be sure to minimize the solvent.
If there is too much solvent, dust may enter the bearings mixed with the solvent, causing abnormal noise.

2-4 Fits

Inappropriate "fitting" causes creep (slip wear), rotation failure (high torque, vibration, heat generation), brinelling, etc.

- Roundness of shaft and housing
Pay attention to the roundness of the shaft and housing.
The shape of the shaft and housing is transferred to the raceways of the inner and outer rings, resulting in poor roundness and vibration, abnormal noise and runout.
In particular, care must be taken with miniature bearings as they are easily deformed.
- Dimensions of shaft and housing
Make sure that the shaft and housing dimensions are correct.
Excessive press-fitting of the "fit" surface due to dimensional defects may cause rotation problems (torque, vibration, heat generation), brinelling, etc.
- Shaft and housing shapes (precautions on design)
Pay attention to the shape of the shaft and housing.
The roundness of the inner and outer rings may be deteriorated due to the discontinuous shape of the shaft outer circumference and the screws provided on the end surface of the housing.

1-5 Handling of a Bearing

- Chamfering of shaft and housing
Pay attention to the size and shape of the chamfer of the shaft and the housing where the bearing end face abuts. If chamfer interferes, it will not be assembled at the correct position, causing misalignment (improper assembly precision).
- Burrs and scratches on the shaft and housing
Be sure to check the shaft and housing for burrs and scratches. If burrs are caught on the surface where the bearing contacts, misalignment (assembly precision failure) may occur, or scratches on the "fitting" surface may deteriorate the roundness of the raceways of the inner and outer rings.

- Insert straight (Figure 19-3)
Use the proper jigs and insert straight. Inserting obliquely may cause galling in the shaft and housing, causing misalignment (assembly precision failure) due to entrapment of galling particles and deterioration in roundness due to scratches.
- Vibration (vibration of belt conveyors, etc.)
When using a belt conveyor, try to reduce the vibration. Fretting occurs when micro-vibration is applied to non-rotating bearings.

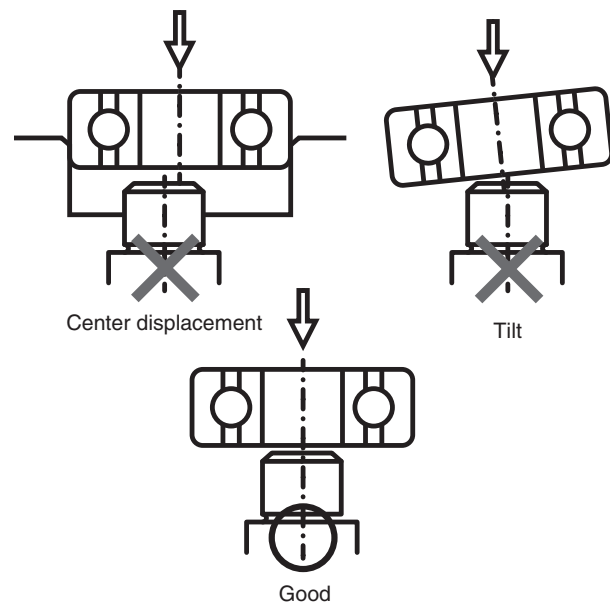

Figure 19-3 Handling in insertion

2-5 Load/Vibration

Incorrect mounting of the bearing onto the shaft or housing may cause brinelling. Fretting may also occur due to vibration of the assembly line. If the transfer to the container is performed in a rough manner, the bearings may collide with each other, causing dents in the shield plate.

- Press the inner ring when press-fitting the shaft (Figure 19-2)
When inserting the bearing into the shaft, press the inner ring side surface. Pressing the outer ring end surface causes brinelling.
- Press the outer ring when press-fitting into the housing (Figure 19-2)
When inserting the bearing into the housing, push the outer ring end surface. Pressing the inner ring end surface causes brinelling.

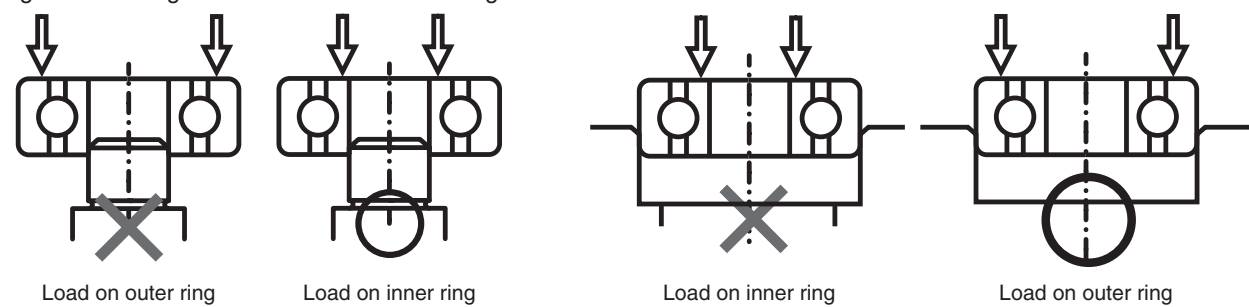

Figure 19-2 Load position in press-fitting

2-6 Adhesive

When using an adhesive to fix the bearing, use care to avoid penetration into the bearing and uneven thickness. Abnormal noise and rotation failure may occur. In particular, be careful with miniature bearings as it is difficult to work with, and the inner and outer rings are thin and easily deformed. Make sure you understand and use the type and properties of the adhesive.

- Preventing adhesive penetration (Figure 19-4)
Take measures such as providing a groove for the adhesive reservoir on the shaft and housing. Also, apply the coating to the shaft end, chamfered part of the bearing, etc.
- Managing the application amount
Control the volume with a dispenser etc. to minimize the amount.
- Make sure there is no uneven adhesive
Uneven thickness may deteriorate the roundness of the bearings. Be sure to apply the adhesive evenly.

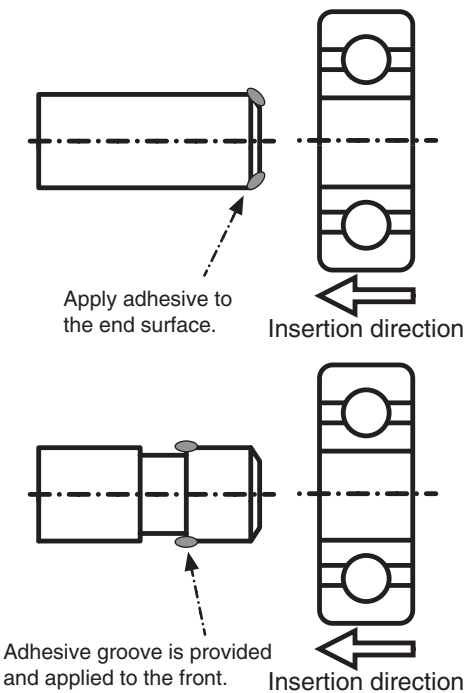

Figure 19-4 Applying adhesive (example)

2-7 Air blowing

Compressed air may be used for dust removal, etc., but depending on how it is sprayed, abnormal noise and rotational issues may occur.

2-8 Applying grease to the housing

Grease may be applied to the housing to reduce noise and vibration, but care must be taken with the used grease.

- Do not use greases with different properties
Performance may be affected by mixing greases with different properties with the grease sealed in the bearing.
- Use a clean grease
If contaminated grease is used, foreign matter will enter the bearing and generate abnormal noise.

2-9 Varnish gas

When impregnating the motor coil with varnish, varnish gas may be generated due to insufficient drying, which may cause rusting. Abnormal noise may also occur.

2-10 Chemical attack

If the bearing assembly is made of resin, oil may cause chemical attack (resin cracking).

- Checking the resin material
The degree of chemical attack varies depending on the resin material. Understand the properties of the materials.
- Checking the fit tolerance
If the strain amount is large, chemical attack is likely to occur. Be sure to check the dimensions before use.

2-11 Effect of magnetization

Avoid magnetizing the bearings. Attracts iron-based foreign matter and causes abnormal noise and misalignment (assembly precision failure).

1-6 Trouble Symptoms, Causes and Countermeasures

In the event of an abnormality in the equipment incorporating the ball bearing, or damage or breakage of the ball bearing, the cause can be investigated based on the symptoms and conditions. The following shows typical abnormalities and countermeasures.

Abnormal symptoms and conditions

Symptoms and conditions		Bearing damage, assumed cause, etc.	Damage example	Countermeasures
Abnormal sound	Continuous sound	Raceway brinelling	3	Reviewing handling of bearings, assembling and transporting equipment (whether excessive load or impact load is applied)
		Roughness and wear	1	Reviewing lubricant, bearing size, preload and seal
		Scratches due to foreign matter in the raceway (indentation)	2	Using seal for bearings and reviewing work environment
		Fretting	4	Reviewing vibration elimination, packaging and transportation
		Electrical arc pitting	6	Insulation: Make the ball ceramic
		Component resonance		Reviewing dimensions (thickness) and material of components
	Variable sound	When the ball is scratched		Reviewing work environment and work (whether foreign matter is intruding or excessive load is applied)
		Biting of foreign matter		Using seal for bearings and reviewing work environment
		Insufficient preload		Reviewing preload amount based on load, rotation conditions, etc.
	Rotation failure	Does not rotate or rotation is heavy	Effect (amount, type) of lubricant (grease)	
Foreign matter penetration, adhesive penetration				Reviewing usage environment and work methods
Large interference				Reviewing fits
Out of lubrication				Reviewing lubricants and increasing the amount of grease Reviewing the grease type and amount
Flaking			8	Checking load and rotation conditions Selecting a larger bearing
Component contact				Reviewing work and design
Heat generation		Incorrect grease type and filling amount		Reviewing grease
		Overload		Reviewing load capacity and fits
Short life		Unsuitable environment, usage conditions, etc.		Reviewing environment and usage conditions
Large vibration and runout		Misalignment		Reviewing component dimensional tolerance, cleanliness and process
	Deformation of track surface		Reviewing machining precision (roundness) of shaft or housing Reviewing adhesives and bonding work	
	Improper preload Preload reduction		Reviewing preload amount based on load, rotation conditions, etc.	
	Excessive internal clearance		Reducing bearing internal clearance	
	Creep	5	Reviewing fits	
Grease leakage	Incorrect grease type and filling amount		Reviewing grease	
	Incorrect selection of shield/seal		Reviewing shield and seal	
Damaged (cracked) resin material	Chemical attack	7	Reviewing lubricants, relieving stress and reselecting resin	
	Excessive interference		Reviewing fits	
	Weld line		Reviewing molding conditions and gate position	

Note: Damages are numbered in order of frequency of occurrence

Damage example

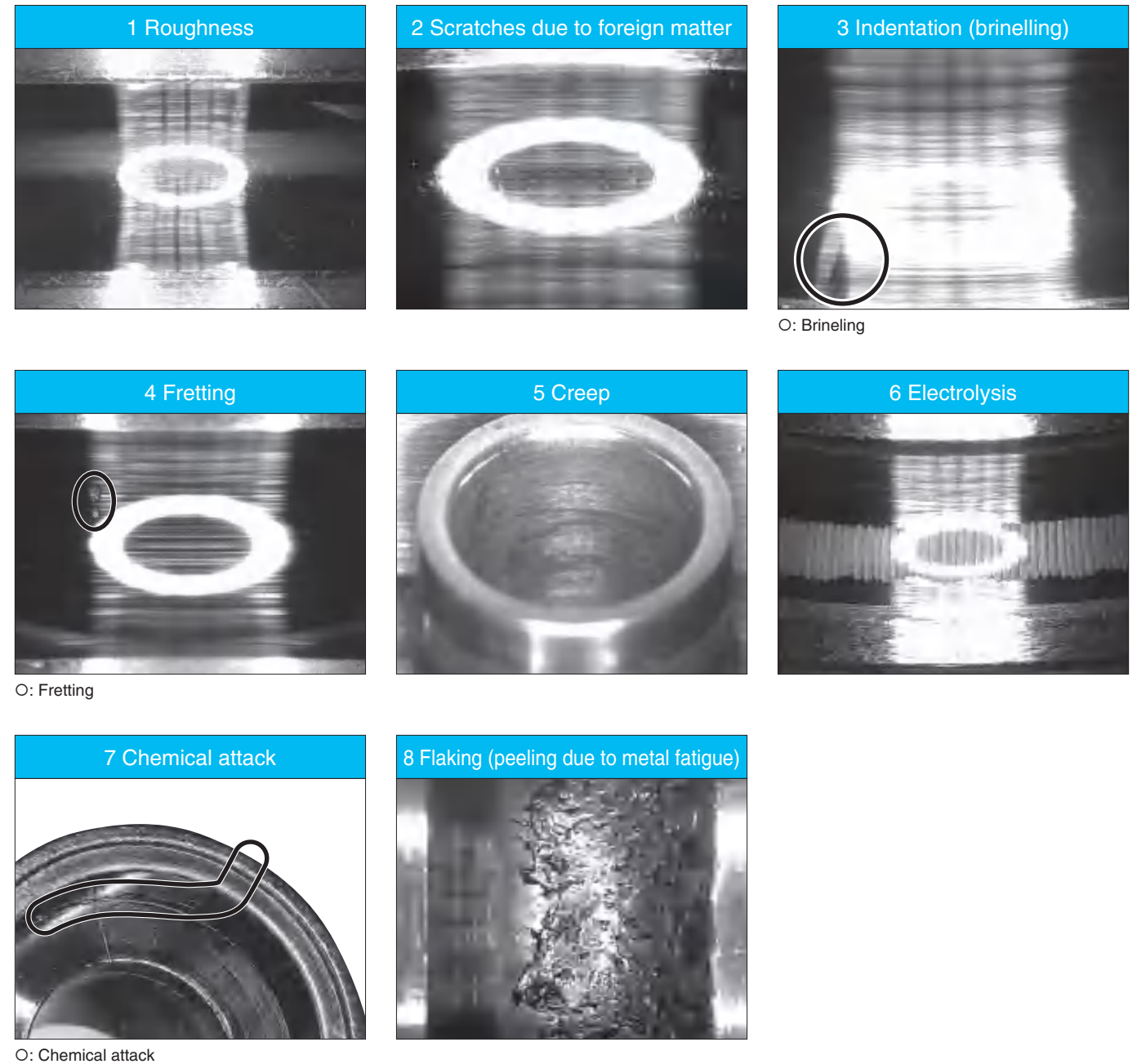

2

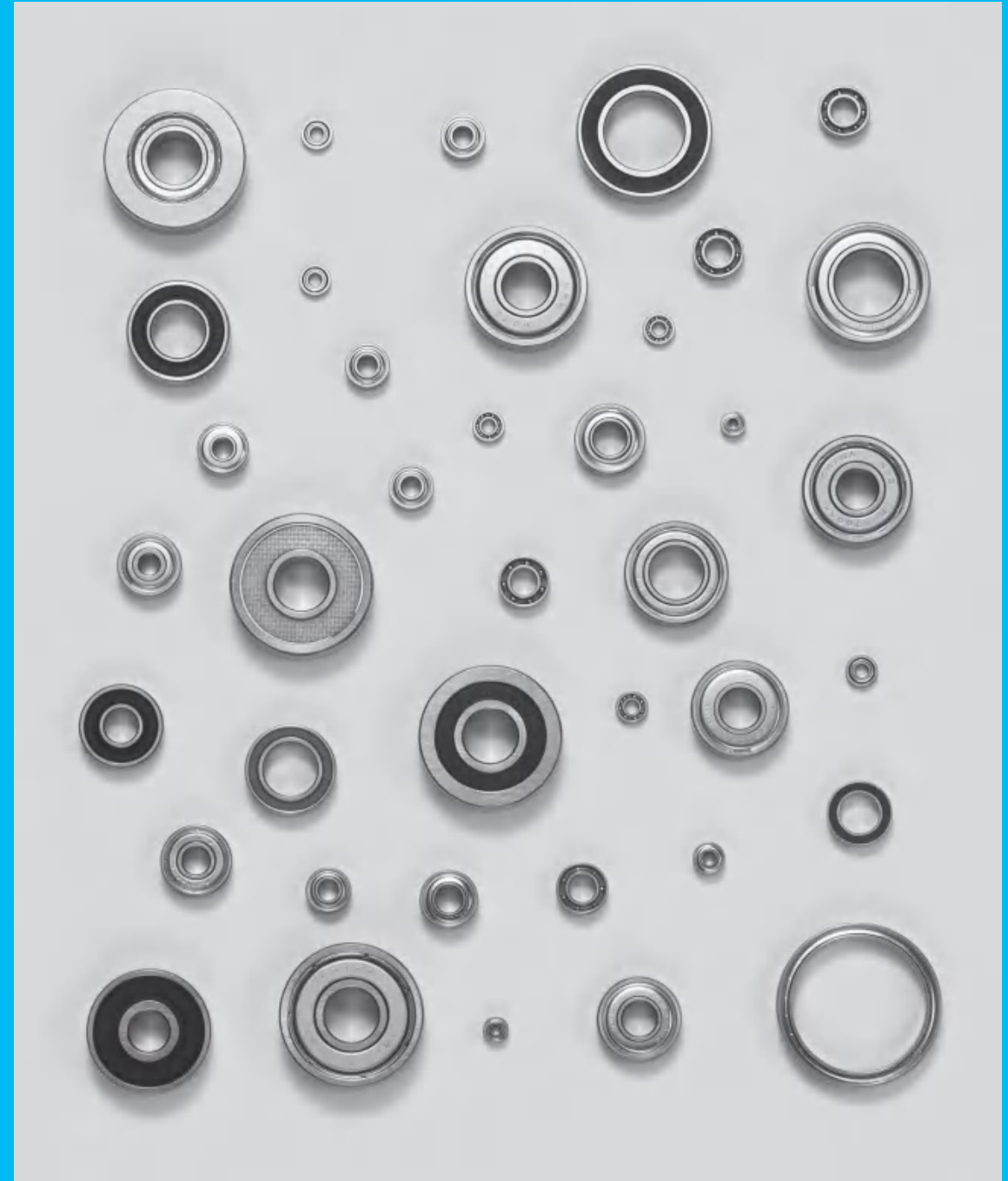

Dimensions

Radial deep groove ball bearings

Metric size: Basic (chrome steel)

R- Series
L- Series
JIS- Series

Inner diameter: 1mm to 6mm

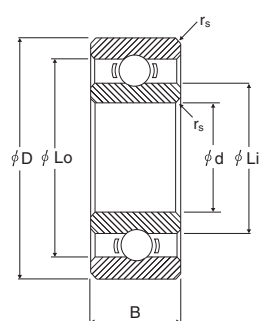

Open Radial Open Ball Bearings

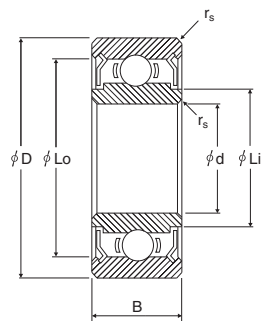

Shielded Radial Shielded Ball Bearings

(Unit: mm)

Part number	Inner diameter d	Outer diameter D	Width B	Chamfer r _s min.	Shoulder diameter		Ball		Basic rated load (N)		Reference JIS number
					Outer ring Lo	Inner ring Li	Dimensions	Quantity (pcs)	Dynamic load Cr	Static load Cor	
L-310	1	3	1	0.05	2.41	1.60	0.5000	7	80	23	681
L-415	1.5	4	1.2	0.05	3.25	2.26	0.6350	7	125	38	68/1.5
L-415X5ZZ	1.5	4	2	0.05	3.42	2.15	0.6000	7	113	34	68/1.5
L-520	2	5	1.5	0.08	4.00	2.90	0.7938	7	187	59	682
L-520ZZ	2	5	2.3	0.08	4.28	2.90	0.7938	7	187	59	-
L-520W52	2	5	2.5	0.08	4.00	2.90	0.7938	7	187	59	-
L-520ZZW52	2	5	2.5	0.08	4.28	2.90	0.7938	7	187	59	-
L-520X9ZZW52	2	5	2.5	0.08	4.27	2.72	0.7938	7	186	58	-
R-620ZZ	2	6	3	0.15	5.23	3.10	1.1906	6	330	99	-
R-620W52	2	6	2.5	0.15	4.93	3.10	1.1906	6	330	99	-
R-620ZZY52	2	6	2.5	0.15	5.23	3.10	1.1906	6	330	99	-
R-720ZZ	2	7	3.5	0.15	5.93	3.80	1.1906	7	380	126	-
L-625ZZ	2.5	6	2.6	0.08	5.23	3.80	0.7938	8	206	73	-
R-725ZZ	2.5	7	3.5	0.15	5.93	3.80	1.1906	7	380	126	-
R-825ZZ	2.5	8	4	0.15	7.19	4.10	1.5875	6	553	176	-
L-630	3	6	2	0.08	4.93	3.80	0.7938	8	206	73	673
L-630ZZ	3	6	2.5	0.08	5.23	3.80	0.7938	8	206	73	-
L-730	3	7	2	0.1	5.83	4.10	1.1906	7	384	129	683
L-730ZZ	3	7	3	0.1	6.13	4.10	1.1906	7	384	129	-
R-830	3	8	3	0.15	6.53	4.10	1.5875	6	553	176	693
R-830ZZ	3	8	4	0.15	7.19	4.10	1.5875	6	553	176	-
R-830X10ZZ	3	8	4	0.15	7.19	4.18	1.5875	6	553	176	-
R-930ZZY04	3	9	4	0.15	7.64	4.80	1.5875	7	634	219	-
R-1030	3	10	4	0.15	8.20	5.08	1.5875	7	641	226	623
R-1030ZZ	3	10	4	0.15	8.20	5.08	1.5875	7	641	226	623ZZ
L-740ZZ	4	7	2.5	0.08	6.33	4.80	0.7938	11	252	106	674
L-840ZZ	4	8	3	0.1	7.24	5.20	1.1906	7	391	140	-
L-940	4	9	2.5	0.1	7.48	5.20	1.5875	7	641	226	684
L-940ZZ	4	9	4	0.1	7.93	5.20	1.5875	7	641	226	-
L-1040X2	4	10	3	0.15	7.96	5.80	1.5875	8	708	266	-
L-1040X2ZZ	4	10	4	0.15	8.50	5.46	1.5875	8	708	266	-

(Unit: mm)

Part number	Inner diameter d	Outer diameter D	Width B	Chamfer r _s min.	Shoulder diameter		Ball		Basic rated load (N)		Reference JIS number
					Outer ring Lo	Inner ring Li	Dimensions	Quantity (pcs)	Dynamic load Cr	Static load Cor	
R-1140	4	11	4	0.15	9.54	6.40	1.5875	8	714	276	694
R-1140ZZ	4	11	4	0.15	9.54	6.40	1.5875	8	714	276	694ZZ
R-1240	4	12	4	0.2	9.99	5.62	2.0000	7	959	347	604
R-1240KK1	4	12	4	0.2	9.68	5.62	2.0000	7	959	347	604ZZ
R-1340	4	13	5	0.2	11.22	5.97	2.3813	7	1306	487	624
R-1340HH	4	13	5	0.2	11.22	5.97	2.3813	7	1306	487	624ZZ
R-1340DD	4	13	5	0.2	11.22	5.97	2.3813	7	1306	487	624DD
R-1640	4	16	5	0.3	13.41	7.80	2.7781	7	1735	671	634
R-1640HH	4	16	5	0.3	13.41	7.80	2.7781	7	1735	671	634ZZ
R-1640DD	4	16	5	0.3	13.41	7.80	2.7781	7	1735	671	634DD
L-850	5	8	2	0.08	6.95	5.80	0.7938	13	274	130	675
L-850ZZ	5	8	2.5	0.08	7.26	5.80	0.7938	13	274	130	-
L-950ZZ	5	9	3	0.1	8.04	6.00	1.1906	10	495	207	-
L-1050	5	10	3	0.1	8.63	6.40	1.5875	8	714	276	-
L-1050ZZ	5	10	4	0.1	8.94	6.40	1.5875	8	714	276	-
L-1050SS	5	10	4	0.1	8.94	6.40	1.5875	8	714	276	-
L-1150	5	11	3	0.15	8.63	6.40	1.5875	8	714	276	685
L-1150ZZ	5	11	5	0.15	9.54	6.40	1.5875	8	714	276	-
L-1150ZZY04	5	11	4	0.15	9.54	6.40	1.5875	8	714	276	-
R-1350	5	13	4	0.2	11.14	6.66	2.0000	8	1074	422	695
R-1350ZZ	5	13	4	0.2	11.14	6.66	2.0000	8	1074	422	695ZZ
R-1350DD	5	13	4	0.2	11.14	6.66	2.0000	8	1074	422	695DD
R-1350X2ZZ	5	13	4	0.2	11.14	6.66	2.0000	8	1074	422	695ZZ
R-1350X2DD	5	13	4	0.2	11.14	6.66	2.0000	8	1074	422	695DD
R-1350X2SS	5	13	4	0.2	11.14	6.66	2.0000	8	1074	422	695SS
R-1450	5	14	5	0.2	12.14	6.88	2.3813	7	1329	508	605
R-1450ZZ	5	14	5	0.2	12.14	6.88	2.3813	7	1329	508	605ZZ
R-1650	5	16	5	0.3	12.50	7.80	2.7781	7	1735	671	625
R-1650HH	5	16	5	0.3	13.41	7.80	2.7781	7	1735	671	625ZZ
R-1650DD	5	16	5	0.3	13.41	7.80	2.7781	7	1735	671	625DD
R-1650SS	5	16	5	0.3	13.41	7.80	2.7781	7	1735	671	625SS
635	5	19	6	0.3	16.68	9.20	3.5000	7	2614	1053	635
635ZZ	5	19	6	0.3	16.68	9.20	3.5000	7	2614	1053	635ZZ
L-1060	6	10	2.5	0.1	8.73	6.95	1.1906	9	457	194	676
L-1060ZZ	6	10	3	0.1	9.04	6.95	1.1906	9	457	194	-
L-1060DD	6	10	3	0.1	9.04	6.95	1.1906	9	457	194	-
L-1060SS	6	10	3	0.1	9.04	6.95	1.1906	9	457	194	-
L-1260	6	12	3	0.15	9.94	7.70	1.5875	10	831	363	-
L-1260ZZ	6	12	4	0.15	10.48	7.70	1.5875	10	831	363	-
L-1260X2DD	6	12	4	0.15	10.80	7.70	1.5875	10	831	363	-
L-1360	6	13	3.5	0.15	10.98	8.00	2.0000	8	1083	438	686

Radial deep groove ball bearings

Metric size: Basic (chrome steel)

R- Series
L- Series
JIS- Series

Inner diameter: 6mm to 10mm

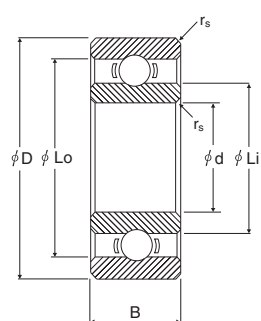

Open Radial Open Ball Bearings

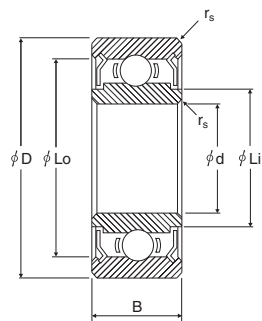

Shielded Radial Shielded Ball Bearings

(Unit: mm)

Part number	Inner diameter d	Outer diameter D	Width B	Chamfer r _s min.	Shoulder diameter		Ball		Basic rated load (N)		Reference JIS number
					Outer ring Lo	Inner ring Li	Dimensions	Quantity (pcs)	Dynamic load Cr	Static load Cor	
L-1360ZZ	6	13	5	0.15	11.44	7.33	2.0000	8	1083	438	-
L-1360DD	6	13	5	0.15	11.44	7.33	2.0000	8	1083	438	-
R-1560X13KK	6	15	5	0.2	13.20	7.80	2.7781	7	1735	671	696ZZ
R-1560X13DD	6	15	5	0.2	13.20	7.80	2.7781	7	1735	671	696DD
R-1660HH	6	16	5	0.3	13.41	7.80	2.7781	7	1735	671	-
R-1660DD	6	16	5	0.3	13.41	7.80	2.7781	7	1735	671	-
R-1760X2	6	17	6	0.3	14.70	8.22	3.5000	6	2265	839	606
R-1760X2KK	6	17	6	0.3	14.70	8.22	3.5000	6	2265	839	606ZZ
R-1760X2DD	6	17	6	0.3	14.70	8.22	3.5000	6	2265	839	606DD
626	6	19	6	0.3	16.68	9.20	3.5000	7	2614	1053	626
626ZZ	6	19	6	0.3	16.68	9.20	3.5000	7	2614	1053	626ZZ
626DD	6	19	6	0.3	16.68	9.20	3.5000	7	2614	1053	626DD
626SS	6	19	6	0.3	16.68	9.20	3.5000	7	2614	1053	626SS
L-1370ZZ	7	13	4	0.15	11.54	8.43	1.5875	11	880	414	-
L-1470	7	14	3.5	0.15	12.03	9.00	2.0000	9	1175	511	687
L-1470KK	7	14	5	0.15	12.88	9.00	2.0000	9	1175	511	-
607	7	19	6	0.3	16.68	9.20	3.5000	7	2614	1053	607
607ZZ	7	19	6	0.3	16.68	9.20	3.5000	7	2614	1053	607ZZ
607DD	7	19	6	0.3	16.68	9.20	3.5000	7	2614	1053	607DD
607SS	7	19	6	0.3	16.68	9.20	3.5000	7	2614	1053	607SS
627	7	22	7	0.3	19.10	10.80	3.9688	7	3297	1368	627
627ZZ	7	22	7	0.3	19.10	10.80	3.9688	7	3297	1368	627ZZ
627DD	7	22	7	0.3	19.10	10.80	3.9688	7	3297	1368	627DD
627SS	7	22	7	0.3	19.10	10.80	3.9688	7	3297	1368	627SS
L-1280ZZ	8	12	3.5	0.1	11.24	9.10	1.1906	11	506	249	-
L-1280DD	8	12	3.5	0.1	11.24	9.10	1.1906	11	506	249	-
L-1480ZZ	8	14	4	0.15	12.55	9.90	1.5875	10	819	386	-
L-1480DD	8	14	4	0.15	12.55	9.90	1.5875	10	819	386	-
L-1680	8	16	4	0.2	13.40	10.30	2.3813	9	1606	712	688
L-1680KK	8	16	5	0.2	14.18	9.68	2.3813	9	1606	712	-
L-1680DD	8	16	5	0.2	14.18	9.68	2.3813	9	1606	712	-

(Unit: mm)

Part number	Inner diameter d	Outer diameter D	Width B	Chamfer r _s min.	Shoulder diameter		Ball		Basic rated load (N)		Reference JIS number
					Outer ring Lo	Inner ring Li	Dimensions	Quantity (pcs)	Dynamic load Cr	Static load Cor	
R-1980	8	19	6	0.3	16.68	10.60	3.1750	8	2463	1059	698
R-1980KK	8	19	6	0.3	16.68	10.60	3.1750	8	2463	1059	698ZZ
R-1980DD	8	19	6	0.3	16.68	10.60	3.1750	8	2463	1059	698DD
R-1980SS	8	19	6	0.3	16.68	10.60	3.1750	8	2463	1059	698SS
608	8	22	7	0.3	19.10	10.80	3.9688	7	3297	1368	608
608ZZ	8	22	7	0.3	19.10	10.80	3.9688	7	3297	1368	608ZZ
608DD	8	22	7	0.3	19.10	10.80	3.9688	7	3297	1368	608DD
608SS	8	22	7	0.3	19.10	10.80	3.9688	7	3297	1368	608SS
R-2480	8	24	8	0.3	19.10	11.80	3.9688	7	3297	1368	628
R-2480KK	8	24	8	0.3	19.10	11.80	3.9688	7	3297	1368	628ZZ
L-1790	9	17	4	0.2	14.84	11.20	2.3813	10	1724	813	689
L-1790ZZ	9	17	5	0.2	15.34	11.20	2.3813	10	1724	813	-
L-1790DD	9	17	5	0.2	15.34	11.20	2.3813	10	1724	813	-
L-2090	9	20	6	0.3	16.71	12.32	2.7781	9	2123	985	699
L-2090KK	9	20	6	0.3	17.44	12.32	2.7781	9	2123	985	699ZZ
609	9	24	7	0.3	19.10	12.40	3.9688	7	3297	1368	609
609ZZ	9	24	7	0.3	19.10	12.40	3.9688	7	3297	1368	609ZZ
609DD	9	24	7	0.3	19.10	12.40	3.9688	7	3297	1368	609DD
609SS	9	24	7	0.3	19.10	12.40	3.9688	7	3297	1368	609SS
629ZZSD61	9	26	8	(0.6)	22.80	12.88	4.7625	7	4578	1970	629ZZ
629DDSD61	9	26	8	(0.6)	22.80	12.88	4.7625	7	4578	1970	629DD
629SSSD61	9	26	8	(0.6)	22.80	12.88	4.7625	7	4578	1970	629SS
L-1910	10	19	5	0.3	16.71	12.32	2.7781	9	2123	985	6800
L-1910DD	10	19	7	0.3	17.44	12.32	2.7781	9	2123	985	-
L-1910KKY05	10	19	5	0.3	17.44	12.32	2.7781	9	2123	985	6800ZZ
L-1910DDY05	10	19	5	0.3	17.44	12.32	2.7781	9	2123	985	6800DD
R-2210X3KK	10	22	6	0.3	19.40	13.40	3.1750	9	2697	1273	6900ZZ
R-2210X3DD	10	22	6	0.3	19.40	13.40	3.1750	9	2697	1273	6900DD
R-2210X3SS	10	22	6	0.3	19.40	13.40	3.1750	9	2697	1273	6900SS
6000	10	26	8	0.3	22.80	13.75	4.7625	7	4578	1970	6000
6000ZZ	10	26	8	0.3	22.80	13.75	4.7625	7	4578	1970	6000ZZ
6000DD	10	26	8	0.3	22.80	13.75	4.7625	7	4578	1970	6000DD
6000SS	10	26	8	0.3	22.80	13.75	4.7625	7	4578	1970	6000SS
L-2112	12	21	5	0.3	19.22	14.40	2.3813	12	1917	1042	6801
L-2112KK	12	21	5	0.3	19.22	14.40	2.3813	12	1917	1042	6801ZZ
L-2112DD	12	21	5	0.3	19.22	14.40	2.3813	12	1917	1042	6801DD
L-2112SS	12	21	5	0.3	19.22	14.40	2.3813	12	1917	1042	6801SS
R-2412X3	12	24	6	0.3	21.69	14.28	3.5719	8	3082	1433	6901
R-2412X3KK	12	24	6	0.3	21.69	14.28	3.5719	8	3082	1433	6901ZZ
R-2412X3DD	12	24	6	0.3	21.69	14.28	3.5719	8	3082	1433	6901DD

Those with parentheses are outside the JIS standard.

Radial deep groove ball bearings

Metric size: Basic (stainless steel)

R- Series
L- Series

Inner diameter: 1mm to 5mm

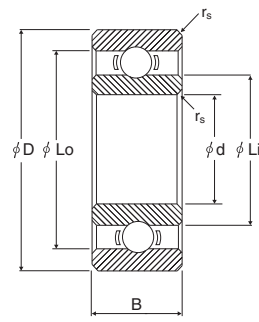

Open Radial Open Ball Bearings

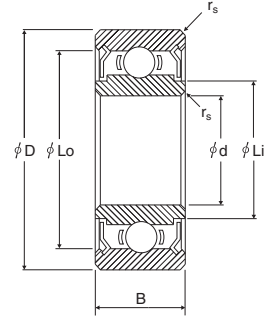

Shielded Radial Shielded Ball Bearings

(Unit: mm)

Part number	Inner diameter d	Outer diameter D	Width B	Chamfer r _s min.	Shoulder diameter		Ball		Basic rated load (N)		Reference JIS number
					Outer ring Lo	Inner ring Li	Dimensions	Quantity (pcs)	Dynamic load	Static load	
									Cr	Cor	
DDL-310	1	3	1	0.05	2.41	1.60	0.5000	7	80	23	681
DDR-410	1	4	1.6	0.1	3.16	2.05	0.7938	6	158	44	691
DDR-410XZZ	1	4	2	0.1	3.49	2.26	0.6350	7	125	38	-
DDR-412	1.2	4	1.8	0.1	3.16	2.05	0.7938	6	158	44	-
DDL-415	1.5	4	1.2	0.05	3.25	2.26	0.6350	7	125	38	68/1.5
DDL-415ZZ	1.5	4	2	0.05	3.49	2.26	0.6350	7	125	38	-
DDR-515	1.5	5	2	0.15	3.73	2.60	0.7938	7	184	57	69/1.5
DDR-515ZZ	1.5	5	2.6	0.15	4.03	2.60	0.7938	7	184	57	-
DDR-615	1.5	6	2.5	0.15	4.73	2.90	1.1906	6	324	97	60/1.5
DDR-615ZZ	1.5	6	3	0.15	5.06	2.90	1.1906	6	324	97	-
DDL-420	2	4	1.2	0.05	3.44	2.57	0.6000	8	125	41	672
DDL-520	2	5	1.5	0.08	4.00	2.90	0.7938	7	187	59	682
DDL-520ZZ	2	5	2.3	0.08	4.28	2.90	0.7938	7	187	59	-
DDL-520W52	2	5	2.5	0.08	4.00	2.90	0.7938	7	187	59	-
DDL-520ZZW52	2	5	2.5	0.08	4.28	2.90	0.7938	7	187	59	-
DDR-620	2	6	2.3	0.15	4.78	3.16	1.0000	7	279	89	692
DDR-620ZZY32	2	6	2.3	0.15	5.23	3.16	1.0000	7	279	89	692ZZ
DDR-620W52	2	6	2.5	0.15	4.93	3.10	1.1906	6	330	99	-
DDR-620ZZY52	2	6	2.5	0.15	5.23	3.10	1.1906	6	330	99	-
DDR-620ZZ	2	6	3	0.15	5.23	3.10	1.1906	6	330	99	-
DDR-720	2	7	2.8	0.15	5.52	3.80	1.1906	7	380	126	602
DDR-720ZZ	2	7	3.5	0.15	5.93	3.80	1.1906	7	380	126	-
DDR-720ZZY03	2	7	3	0.15	5.93	3.80	1.1906	7	380	126	-
DDL-625	2.5	6	1.8	0.08	4.93	3.80	0.7938	8	206	73	68/2.5
DDL-625ZZ	2.5	6	2.6	0.08	5.23	3.80	0.7938	8	206	73	-
DDR-725	2.5	7	2.5	0.15	5.52	3.80	1.1906	7	380	126	69/2.5
DDR-725ZZ	2.5	7	3.5	0.15	5.93	3.80	1.1906	7	380	126	-
DDR-825	2.5	8	2.8	0.15	6.53	4.10	1.5875	6	553	176	60/2.5
DDR-825ZZ	2.5	8	4	0.15	7.19	4.10	1.5875	6	553	176	-
DDL-630	3	6	2	0.08	4.93	3.80	0.7938	8	206	73	673
DDL-630ZZ	3	6	2.5	0.08	5.23	3.80	0.7938	8	206	73	-

(Unit: mm)

Part number	Inner diameter d	Outer diameter D	Width B	Chamfer r _s min.	Shoulder diameter		Ball		Basic rated load (N)		Reference JIS number
					Outer ring Lo	Inner ring Li	Dimensions	Quantity (pcs)	Dynamic load	Static load	
									Cr	Cor	
DDL-730	3	7	2	0.1	5.83	4.10	1.1906	7	384	129	683
DDL-730ZZ	3	7	3	0.1	6.13	4.10	1.1906	7	384	129	-
DDR-830	3	8	3	0.15	6.53	4.10	1.5875	6	553	176	693
DDR-830ZZ	3	8	4	0.15	7.19	4.10	1.5875	6	553	176	-
DDR-930	3	9	3	0.15	7.23	4.80	1.5875	7	634	219	603
DDR-930ZZ	3	9	5	0.15	7.64	4.80	1.5875	7	634	219	-
DDR-930ZZY04	3	9	4	0.15	7.64	4.80	1.5875	7	634	219	-
DDR-1030	3	10	4	0.15	7.65	5.08	1.5875	7	641	226	623
DDR-1030ZZ	3	10	4	0.15	8.20	5.08	1.5875	7	641	226	623ZZ
DDL-740	4	7	2	0.08	5.93	4.80	0.7938	11	252	106	674
DDL-740ZZ	4	7	2.5	0.08	6.33	4.80	0.7938	11	252	106	-
DDL-840	4	8	2	0.1	6.93	5.20	1.1906	7	391	140	-
DDL-840ZZ	4	8	3	0.1	7.24	5.20	1.1906	7	391	140	-
DDL-940	4	9	2.5	0.1	7.48	5.20	1.5875	7	641	226	684
DDL-940ZZ	4	9	4	0.1	7.93	5.20	1.5875	7	641	226	-
DDL-1040	4	10	3	0.15	7.96	5.80	1.5875	8	708	266	-
DDL-1040ZZ	4	10	4	0.15	8.50	5.46	1.5875	8	708	266	-
DDR-1140	4	11	4	0.15	8.63	6.40	1.5875	8	714	276	694
DDR-1140ZZ	4	11	4	0.15	9.54	6.40	1.5875	8	714	276	694ZZ
DDR-1240	4	12	4	0.2	8.95	5.62	2.0000	7	959	347	604
DDR-1240ZZ	4	12	4	0.2	9.90	5.62	2.0000	7	959	347	604ZZ
DDR-1340	4	13	5	0.2	11.22	5.97	2.3813	7	1306	487	624
DDR-1340ZZ	4	13	5	0.2	11.04	7.00	2.3813	7	1306	487	624ZZ
DDR-1340DD	4	13	5	0.2	11.04	7.00	2.3813	7	1306	487	624DD
DDL-850	5	8	2	0.08	6.95	5.80	0.7938	13	274	130	675
DDL-850ZZ	5	8	2.5	0.08	7.26	5.80	0.7938	13	274	130	-
DDL-950	5	9	2.5	0.1	7.73	6.00	1.1906	10	495	207	-
DDL-950ZZ	5	9	3	0.1	8.04	6.00	1.1906	10	495	207	-
DDL-1050	5	10	3	0.1	8.63	6.40	1.5875	8	714	276	-
DDL-1050ZZ	5	10	4	0.1	8.94	6.40	1.5875	8	714	276	-
DDL-1050SS	5	10	4	0.1	8.94	6.40	1.5875	8	714	276	-
DDL-1150	5	11	3	0.15	8.63	6.40	1.5875	8	714	276	685
DDL-1150ZZ	5	11	5	0.15	9.54	6.40	1.5875	8	714	276	-
DDL-1150W04	5	11	4	0.15	9.54	6.40	1.5875	8	714	276	-
DDL-1150ZZY04	5	11	4	0.15	9.54	6.40	1.5875	8	714	276	-
DDR-1350	5	13	4	0.2	11.14	6.66	2.0000	8	1074	422	695
DDR-1350ZZ	5	13	4	0.2	11.14	6.66	2.0000	8	1074	422	695ZZ
DDR-1450	5	14	5	0.2	12.14	6.88	2.3813	7	1329	508	605
DDR-1450ZZ	5	14	5	0.2	12.14	6.88	2.3813	7	1329	508	605ZZ
DDR-1650	5	16	5	0.3	12.50	7.80	2.7781	7	1735	671	625
DDR-1650HH	5	16	5	0.3	13.41	7.80	2.7781	7	1735	671	625ZZ
DDR-1650DD	5	16	5	0.3	13.41	7.80	2.7781	7	1735	671	625DD
DDR-1950	5	19	6	0.3	15.63	8.67	3.9688	6	2805	1060	635

Radial deep groove ball bearings

Metric size: Basic (stainless steel)

R- Series
L- Series
Inner diameter: 5mm to 20mm

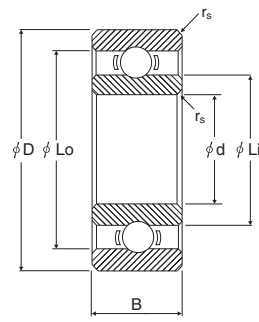

Open Radial Open Ball Bearings

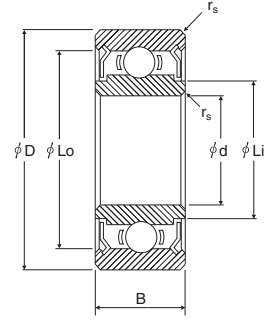

Shielded Radial Shielded Ball Bearings

(Unit: mm)

Part number	Inner diameter d	Outer diameter D	Width B	Chamfer r_s min.	Shoulder diameter		Ball		Basic rated load (N)		Reference JIS number
					Outer ring Lo	Inner ring Li	Dimensions	Quantity (pcs)	Dynamic load	Static load	
									Cr	Cor	
DDR-1950ZZ	5	19	6	0.3	16.26	8.67	3.9688	6	2805	1060	635ZZ
DDL-1060	6	10	2.5	0.1	8.73	6.95	1.1906	9	457	194	676
DDL-1060ZZ	6	10	3	0.1	9.04	6.95	1.1906	9	457	194	-
DDL-1060DD	6	10	3	0.1	9.04	6.95	1.1906	9	457	194	-
DDL-1260	6	12	3	0.15	9.94	7.70	1.5875	10	831	363	-
DDL-1260ZZ	6	12	4	0.15	10.48	7.70	1.5875	10	831	363	-
DDL-1260X2DD	6	12	4	0.15	10.80	7.70	1.5875	10	831	363	-
DDL-1360	6	13	3.5	0.15	10.98	8.00	2.0000	8	1083	438	686
DDL-1360ZZ	6	13	5	0.15	11.44	7.33	2.0000	8	1083	438	-
DDL-1360DD	6	13	5	0.15	11.44	7.33	2.0000	8	1083	438	-
DDR-1560	6	15	5	0.2	13.20	7.80	2.7781	7	1735	671	696
DDR-1560ZZ	6	15	5	0.2	13.20	7.80	2.7781	7	1735	671	696ZZ
DDR-1560DD	6	15	5	0.2	13.20	7.80	2.7781	7	1735	671	696DD
DDR-1660HH	6	16	5	0.3	13.41	7.80	2.7781	7	1735	671	-
DDR-1760X2	6	17	6	0.3	14.70	8.22	3.5000	6	2265	839	606
DDR-1760X2ZZ	6	17	6	0.3	14.70	8.22	3.5000	6	2265	839	606ZZ
DDR-1760X2DD	6	17	6	0.3	14.70	8.22	3.5000	6	2265	839	606DD
DDR-1960	6	19	6	0.3	15.63	8.67	3.9688	6	2805	1060	626
DDR-1960ZZ	6	19	6	0.3	16.26	8.67	3.9688	6	2805	1060	626ZZ
DDR-1960DD	6	19	6	0.3	16.26	8.67	3.9688	6	2805	1060	626DD
DDL-1170	7	11	2.5	0.1	9.83	8.10	1.1906	9	449	199	677
DDL-1170ZZ	7	11	3	0.1	10.14	8.10	1.1906	9	449	199	-
DDL-1170DD	7	11	3	0.1	10.14	8.10	1.1906	9	449	199	-
DDL-1370	7	13	3	0.15	11.13	8.90	1.5875	11	880	414	-
DDL-1370ZZ	7	13	4	0.15	11.54	8.43	1.5875	11	880	414	-
DDL-1470	7	14	3.5	0.15	12.03	9.00	2.0000	9	1175	511	687
DDL-1470ZZ	7	14	5	0.15	12.45	9.00	2.0000	9	1175	511	-
DDR-1970	7	19	6	0.3	16.24	9.55	3.1750	7	2240	912	607
DDR-1970ZZ	7	19	6	0.3	16.24	9.55	3.1750	7	2240	912	607ZZ
DDR-2270	7	22	7	0.3	19.07	10.80	3.9688	7	3297	1368	627
DDR-2270HH	7	22	7	0.3	19.07	10.80	3.9688	7	3297	1368	627ZZ

(Unit: mm)

Part number	Inner diameter d	Outer diameter D	Width B	Chamfer r_s min.	Shoulder diameter		Ball		Basic rated load (N)		Reference JIS number
					Outer ring Lo	Inner ring Li	Dimensions	Quantity (pcs)	Dynamic load	Static load	
									Cr	Cor	
DDL-1280	8	12	2.5	0.1	10.93	9.10	1.1906	11	506	249	678
DDL-1280ZZ	8	12	3.5	0.1	11.24	9.10	1.1906	11	506	249	-
DDL-1480	8	14	3.5	0.15	12.13	9.90	1.5875	10	819	386	-
DDL-1480ZZ	8	14	4	0.15	12.55	9.90	1.5875	10	819	386	-
DDL-1680	8	16	4	0.2	13.40	10.30	2.3813	9	1606	712	688
DDL-1680HH	8	16	5	0.2	14.23	9.68	2.3813	9	1606	712	-
DDL-1680DD	8	16	5	0.2	14.23	9.68	2.3813	9	1606	712	-
DDR-1980	8	19	6	0.3	16.68	10.60	3.1750	8	2463	1059	698
DDR-1980ZZ	8	19	6	0.3	16.24	9.55	3.1750	8	2463	1059	698ZZ
DDR-1980DD	8	19	6	0.3	16.24	9.55	3.1750	8	2463	1059	698DD
DDR-2280	8	22	7	0.3	19.07	10.80	3.9688	7	3297	1368	608
DDR-2280HH	8	22	7	0.3	19.07	10.80	3.9688	7	3297	1368	608ZZ
DDR-2280DD	8	22	7	0.3	19.07	10.80	3.9688	7	3297	1368	608DD
DDL-1790	9	17	4	0.2	14.84	11.20	2.3813	10	1724	813	689
DDL-1790ZZ	9	17	5	0.2	15.34	11.20	2.3813	10	1724	813	-
DDL-1790DD	9	17	5	0.2	15.34	11.20	2.3813	10	1724	813	-
DDL-2090	9	20	6	0.3	16.71	12.32	2.7781	9	2123	985	699
DDL-2090ZZ	9	20	6	0.3	17.44	12.32	2.7781	9	2123	985	699ZZ
DDA-1510	10	15	3	0.1	13.63	11.25	1.5875	11	857	435	6700
DDA-1510ZZ	10	15	4	0.1	14.04	11.25	1.5875	11	857	435	-
DDL-1910	10	19	5	0.3	16.71	12.32	2.7781	9	2123	985	6800
DDL-1910ZZ	10	19	7	0.3	17.44	12.32	2.7781	9	2123	985	-
DDL-1910DD	10	19	7	0.3	17.44	12.32	2.7781	9	2123	985	-
DDL-1910ZZY05	10	19	5	0.3	17.44	12.32	2.7781	9	2123	985	6800ZZ
DDL-1910DDY05	10	19	5	0.3	17.44	12.32	2.7781	9	2123	985	6800DD
DDR-2210X2	10	22	6	0.3	19.08	12.40	3.1750	9	2697	1273	6900
DDR-2210X2HH	10	22	6	0.3	19.08	12.40	3.1750	9	2697	1273	6900ZZ
DDL-2112	12	21	5	0.3	19.22	14.40	2.3813	12	1917	1042	6801
DDL-2112DD	12	21	5	0.3	19.22	14.40	2.3813	12	1917	1042	6801DD
DDL-2112SS	12	21	5	0.3	19.22	14.40	2.3813	12	1917	1042	6801SS
DDR-2412X3ZZ	12	24	6	0.3	21.69	14.28	3.5719	8	3082	1433	6901ZZ
DDR-2412X3DD	12	24	6	0.3	21.69	14.28	3.5719	8	3082	1433	6901DD
DDA-2015	15	20	3.5	0.15	18.43	16.40	1.5875	14	944	582	-
DDA-2015ZZ	15	20	4.5	0.15	18.76	16.40	1.5875	14	944	582	-
DDA-2115	15	21	3.5	0.15	18.93	16.80	1.5875	14	938	581	-
DDA-2115DD	15	21	4.5	0.15	19.72	16.80	1.5875	14	938	581	-
DDA-2216	16	22	4	0.15	19.93	17.80	1.5875	15	969	619	-
DDA-2216ZZ	16	22	4	0.15	20.72	17.80	1.5875	15	969	619	-
DDA-2216SS	16	22	4	0.15	20.72	17.80	1.5875	15	969	619	-
DDA-2418	18	24	4	0.15	21.93	19.75	1.5875	16	988	654	-
DDA-2520	20	25	4	0.15	23.43	21.35	1.5875	17	1012	691	-
DDA-2520ZZ	20	25	4	0.15	23.84	21.35	1.5875	17	1012	691	-

Radial deep groove ball bearings

Metric size: With flange (chrome steel, stainless steel)

RF- Series
LF- Series
Inner diameter: 1mm to 5mm

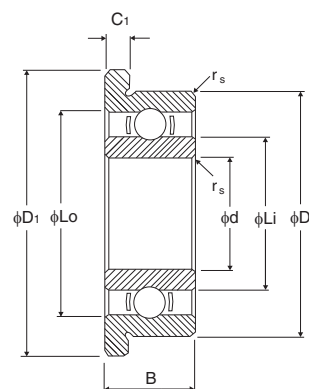

Open type
Radial Flanged Open Ball Bearings

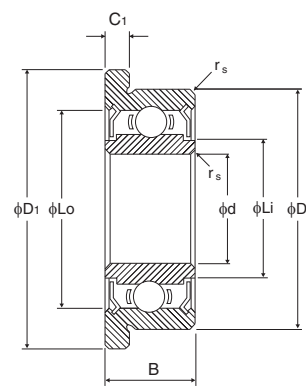

Shielded
Radial Flanged Shielded Ball Bearings

(Unit: mm)

Part number	Inner diameter d	Outer diameter D	Width B	Chamfer r _s min.	Flange		Shoulder diameter		Ball		Basic rated load (N)		Reference JIS number
					Outer diameter D ₁	Width C ₁	Outer ring Lo	Inner ring Li	Dimensions	Quantity (pcs)	Dynamic load Cr	Static load Cor	
DDLDF-310	1	3	1	0.05	3.8	0.3	2.41	1.60	0.5000	7	80	23	F681
DDLDF-415	1.5	4	1.2	0.05	5.0	0.4	3.25	2.26	0.6350	7	125	38	F68/1.5
DDLDF-415ZZ	1.5	4	2	0.05	5.0	0.6	3.49	2.26	0.6350	7	125	38	-
DDRF-515	1.5	5	2	0.15	6.5	0.6	3.73	2.60	0.7938	7	184	57	F69/1.5
DDRF-515ZZ	1.5	5	2.6	0.15	6.5	0.8	4.03	2.60	0.7938	7	184	57	-
DDRF-615ZZ	1.5	6	3	0.15	7.5	0.8	5.06	2.90	1.1906	6	324	97	-
DDLDF-520	2	5	1.5	0.08	6.1	0.5	4.00	2.90	0.7938	7	187	59	F682
DDLDF-520ZZ	2	5	2.3	0.08	6.1	0.6	4.28	2.90	0.7938	7	187	59	-
DDRF-620	2	6	2.3	0.15	7.5	0.6	4.75	3.16	1.0000	7	279	89	F692
DDRF-620ZZ	2	6	3	0.15	7.5	0.8	5.23	3.10	1.1906	6	330	99	-
DDRF-720ZZ	2	7	3.5	0.15	8.5	0.9	5.93	3.80	1.1906	7	380	126	-
DDLDF-625ZZ	2.5	6	2.6	0.08	7.1	0.8	5.23	3.80	0.7938	8	206	73	-
DDRF-725ZZ	2.5	7	3.5	0.15	8.5	0.9	5.93	3.80	1.1906	7	380	126	-
DDRF-825ZZ	2.5	8	4	0.15	9.5	0.9	7.19	4.10	1.5875	6	553	176	-
DDLDF-630	3	6	2	0.08	7.2	0.6	4.93	3.80	0.7938	8	206	73	F673
DDLDF-630ZZ	3	6	2.5	0.08	7.2	0.6	5.23	3.80	0.7938	8	206	73	-
DDLDF-730	3	7	2	0.1	8.1	0.5	5.83	4.10	1.1906	7	384	129	F683
DDLDF-730ZZ	3	7	3	0.1	8.1	0.8	6.13	4.10	1.1906	7	384	129	-
DDRF-830	3	8	3	0.15	9.5	0.7	6.53	4.10	1.5875	6	553	176	F693
DDRF-830ZZ	3	8	4	0.15	9.5	0.9	7.19	4.10	1.5875	6	553	176	-
DDRF-930ZZ	3	9	5	0.15	10.5	1.0	7.64	4.80	1.5875	7	634	219	-

(Unit: mm)

Part number ^{Note}	Inner diameter d	Outer diameter D	Width B	Chamfer r _s min.	Flange		Shoulder diameter		Ball		Basic rated load (N)		Reference JIS number
					Outer diameter D ₁	Width C ₁	Outer ring Lo	Inner ring Li	Dimensions	Quantity (pcs)	Dynamic load Cr	Static load Cor	
DDRF-1030ZZ	3	10	4	0.15	11.5	1.0	8.20	5.08	1.5875	7	641	226	F623ZZ
DDLDF-740	4	7	2	0.08	8.2	0.6	5.93	4.80	0.7938	11	252	106	F674
DDLDF-740ZZ	4	7	2.5	0.08	8.2	0.6	6.33	4.80	0.7938	11	252	106	-
DDLDF-840	4	8	2	0.1	9.2	0.6	6.93	5.20	1.1906	7	391	140	-
DDLDF-840ZZ	4	8	3	0.1	9.2	0.6	7.24	5.20	1.1906	7	391	140	-
DDLDF-940	4	9	2.5	0.1	10.3	0.6	7.48	5.20	1.5875	7	641	226	F684
DDLDF-940ZZ	4	9	4	0.1	10.3	1.0	7.93	5.20	1.5875	7	641	226	-
DDLDF-1040	4	10	3	0.15	11.6	0.6	7.96	5.80	1.5875	8	708	266	-
DDLDF-1040ZZ	4	10	4	0.15	11.6	0.8	8.50	5.46	1.5875	8	708	266	-
DDRF-1140ZZ	4	11	4	0.15	12.5	1.0	9.54	6.40	1.5875	8	714	276	F694ZZ
DDRF-1240	4	12	4	0.2	13.5	1.0	9.99	5.62	2.0000	7	959	347	F604
DDRF-1240ZZ	4	12	4	0.2	13.5	1.0	9.99	5.62	2.0000	7	959	347	F604ZZ
DDRF-1340	4	13	5	0.2	15.0	1.0	11.04	7.00	2.3813	7	1306	487	F624
DDRF-1340ZZ	4	13	5	0.2	15.0	1.0	11.04	7.00	2.3813	7	1306	487	F624ZZ
DDRF-1640ZZ	4	16	5	0.3	18.0	1.0	13.20	7.80	2.7781	7	1735	671	F634ZZ
DDLDF-850	5	8	2	0.08	9.2	0.6	6.95	5.80	0.7938	13	274	130	F675
DDLDF-850ZZ	5	8	2.5	0.08	9.2	0.6	7.26	5.80	0.7938	13	274	130	-
DDLDF-950	5	9	2.5	0.1	10.2	0.6	7.73	6.00	1.1906	10	495	207	-
DDLDF-950ZZ	5	9	3	0.1	10.2	0.6	8.04	6.00	1.1906	10	495	207	-
DDLDF-1050	5	10	3	0.1	11.2	0.6	8.63	6.40	1.5875	8	714	276	-
DDLDF-1050ZZ	5	10	4	0.1	11.6	0.8	8.94	6.40	1.5875	8	714	276	-
LF-1050ZZ	5	10	4	0.1	11.6	0.8	8.94	6.40	1.5875	8	714	276	-
DDLDF-1150	5	11	3	0.15	12.5	0.8	8.63	6.40	1.5875	8	714	276	F685
DDLDF-1150ZZ	5	11	5	0.15	12.5	1.0	9.54	6.40	1.5875	8	714	276	-
LF-1150ZZ	5	11	5	0.15	12.5	1.0	9.54	6.40	1.5875	8	714	276	-
DDRF-1350	5	13	4	0.2	15.0	1.0	11.14	6.66	2.0000	8	1074	422	F695
DDRF-1350ZZ	5	13	4	0.2	15.0	1.0	11.14	6.66	2.0000	8	1074	422	F695ZZ
DDRF-1450	5	14	5	0.2	16.0	1.0	12.14	6.88	2.3813	7	1329	508	F605
DDRF-1450ZZ	5	14	5	0.2	16.0	1.0	12.14	6.88	2.3813	7	1329	508	F605ZZ
RF-1450ZZ	5	14	5	0.2	16.0	1.0	12.14	6.88	2.3813	7	1329	508	F605ZZ
DDRF-1650	5	16	5	0.3	18.0	1.0	13.41	7.80	2.7781	7	1735	671	F625

Note: White columns are chrome steel and blue columns are stainless steel.

Radial deep groove ball bearings

Metric size: With flange (chrome steel, stainless steel)

RF- Series
LF- Series
Inner diameter: 5mm to 10mm

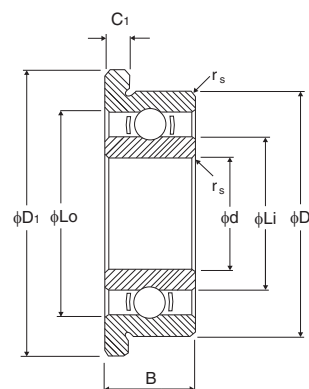

Open type
Radial Flanged Open Ball Bearings

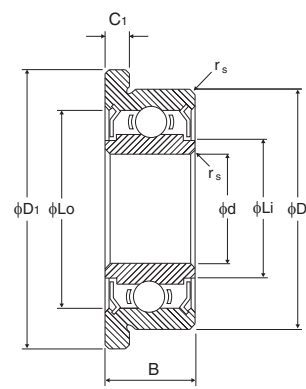

Shielded
Radial Flanged Shielded Ball Bearings

(Unit: mm)

Part number ^{Note}	Inner diameter d	Outer diameter D	Width B	Chamfer r _s min.	Flange		Shoulder diameter		Ball		Basic rated load (N)		Reference JIS number
					Outer diameter D ₁	Width C ₁	Outer ring L _o	Inner ring L _i	Dimensions	Quantity (pcs)	Dynamic load C _r	Static load C _{or}	
DDRF-1650HH	5	16	5	0.3	18.0	1.0	13.41	7.80	2.7781	7	1735	671	F625ZZ
DDRF-1950	5	19	6	0.3	22.0	1.5	15.60	8.67	3.9688	6	2805	1060	F635
DDRF-1950ZZ	5	19	6	0.3	22.0	1.5	16.26	8.67	3.9688	6	2805	1060	F635ZZ
DDLDF-1060	6	10	2.5	0.1	11.2	0.6	8.73	6.95	1.1906	9	457	194	F676
DDLDF-1060ZZ	6	10	3	0.1	11.2	0.6	9.04	6.95	1.1906	9	457	194	-
LF-1060ZZ	6	10	3	0.1	11.2	0.6	9.04	6.95	1.1906	9	457	194	-
DDLDF-1260	6	12	3	0.15	13.2	0.6	9.94	7.70	1.5875	10	831	363	-
DDLDF-1260ZZ	6	12	4	0.15	13.6	0.8	10.48	7.70	1.5875	10	831	363	-
LF-1260ZZ	6	12	4	0.15	13.6	0.8	10.48	7.70	1.5875	10	831	363	-
DDLDF-1360	6	13	3.5	0.15	15.0	1.0	10.98	8.00	2.0000	8	1083	438	F686
DDLDF-1360ZZ	6	13	5	0.15	15.0	1.1	11.44	7.33	2.0000	8	1083	438	-
LF-1360ZZ	6	13	5	0.15	15.0	1.1	11.44	7.33	2.0000	8	1083	438	-
DDRF-1560	6	15	5	0.2	17.0	1.2	13.20	7.80	2.7781	7	1735	671	F696
DDRF-1560ZZ	6	15	5	0.2	17.0	1.2	13.20	7.80	2.7781	7	1735	671	F696ZZ
DDRF-1760X2	6	17	6	0.3	19.0	1.2	14.70	8.22	3.5000	6	2265	839	F606
DDRF-1760X2ZZ	6	17	6	0.3	19.0	1.2	14.70	8.22	3.5000	6	2265	839	F606ZZ
RF-1760X2ZZ	6	17	6	0.3	19.0	1.2	14.70	8.22	3.5000	6	2265	839	F606ZZ
DDRF-1960	6	19	6	0.3	22.0	1.5	16.26	8.67	3.9688	6	2805	1060	F626
DDRF-1960ZZ	6	19	6	0.3	22.0	1.5	16.26	8.67	3.9688	6	2805	1060	F626ZZ
RF-1960ZZ	6	19	6	0.3	22.0	1.5	16.26	8.67	3.9688	6	2805	1060	F626ZZ
DDLDF-1170	7	11	2.5	0.1	12.2	0.6	9.83	8.10	1.1906	9	449	199	F677

Note: White columns are chrome steel and blue columns are stainless steel.

(Unit: mm)

Part number ^{Note}	Inner diameter d	Outer diameter D	Width B	Chamfer r _s min.	Flange		Shoulder diameter		Ball		Basic rated load (N)		Reference JIS number
					Outer diameter D ₁	Width C ₁	Outer ring L _o	Inner ring L _i	Dimensions	Quantity (pcs)	Dynamic load C _r	Static load C _{or}	
DDLDF-1170ZZ	7	11	3	0.1	12.2	0.6	10.14	8.10	1.1906	9	449	199	-
DDLDF-1370	7	13	3	0.15	14.2	0.6	11.13	8.90	1.5875	11	880	414	-
DDLDF-1370ZZ	7	13	4	0.15	14.6	0.8	11.54	8.43	1.5875	11	880	414	-
DDLDF-1470	7	14	3.5	0.15	16.0	1.0	12.03	9.00	2.0000	9	1175	511	F687
DDLDF-1470ZZ	7	14	5	0.15	16.0	1.0	12.45	9.00	2.0000	9	1175	511	-
DDRF-1970ZZ	7	19	6	0.3	22.0	1.5	16.24	9.55	3.1750	7	2240	912	F607ZZ
DDRF-1970DD	7	19	6	0.3	22.0	1.5	16.24	9.55	3.1750	7	2240	912	F607DD
DDRF-2270	7	22	7	0.3	25.0	1.5	19.07	10.80	3.9688	7	3297	1368	F627
DDRF-2270HH	7	22	7	0.3	25.0	1.5	19.07	10.80	3.9688	7	3297	1368	F627ZZ
DDLDF-1280	8	12	2.5	0.1	13.2	0.6	10.93	9.10	1.1906	11	506	249	F678
DDLDF-1280ZZ	8	12	3.5	0.1	13.6	0.8	11.24	9.10	1.1906	11	506	249	-
DDLDF-1280DD	8	12	3.5	0.1	13.6	0.8	11.24	9.10	1.1906	11	506	249	-
DDLDF-1480	8	14	3.5	0.15	15.6	0.8	12.13	9.90	1.5875	10	819	386	-
DDLDF-1480ZZ	8	14	4	0.15	15.6	0.8	12.55	9.90	1.5875	10	819	386	-
LF-1480X3ZZ	8	14	4	0.15	15.6	0.8	12.55	9.90	1.5875	10	819	386	-
LF-1480DD	8	14	4	0.15	15.6	0.8	12.55	9.90	1.5875	10	819	386	-
DDLDF-1680	8	16	4	0.2	18.0	1.0	13.40	10.30	2.3813	9	1606	712	F688
DDLDF-1680HH	8	16	5	0.2	18.0	1.1	14.23	9.68	2.3813	9	1606	712	-
LF-1680HH	8	16	5	0.2	18.0	1.1	14.23	9.68	2.3813	9	1606	712	-
DDRF-1980	8	19	6	0.3	22.0	1.5	16.24	9.55	3.1750	8	2463	1059	F698
DDRF-1980ZZ	8	19	6	0.3	22.0	1.5	16.24	9.55	3.1750	8	2463	1059	F698ZZ
DDRF-1980DD	8	19	6	0.3	22.0	1.5	16.24	9.55	3.1750	8	2463	1059	F698DD
DDRF-2280	8	22	7	0.3	25.0	1.5	18.89	10.80	3.9688	7	3297	1368	F608
DDRF-2280HH	8	22	7	0.3	25.0	1.5	19.07	10.80	3.9688	7	3297	1368	F608ZZ
RF-2280	8	22	7	0.3	25.0	1.5	18.89	10.80	3.9688	7	3297	1368	F608
RF-2280HH	8	22	7	0.3	25.0	1.5	19.07	10.80	3.9688	7	3297	1368	F608ZZ
DDLDF-1790	9	17	4	0.2	19.0	1.0	14.84	11.20	2.3813	10	1724	813	F689
DDLDF-1790ZZ	9	17	5	0.2	19.0	1.1	15.34	11.20	2.3813	10	1724	813	-
DDLDF-1910ZZ	10	19	7	0.3	22.0	1.5	17.44	12.32	2.7781	9	2123	985	-
DDRF-2210X2HH	10	22	6	0.3	25.0	1.5	19.08	12.40	3.1750	9	2697	1273	F6900ZZ

Note: White columns are chrome steel and blue columns are stainless steel.

Radial deep groove ball bearings

Metric size: With retaining ring (chrome steel)

NR- Series

Inner diameter: 5mm to 12mm

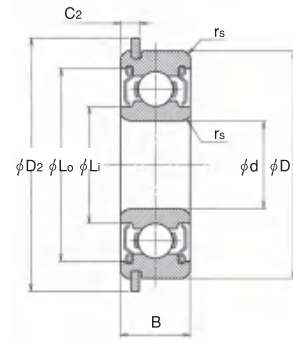

Shielded
Radial Shielded Ball Bearings with locating snap ring

(Unit: mm)

Part number	Inner diameter d	Outer diameter D	Width B	Chamfer r's min.	Retaining Ring		Shoulder diameter		Ball		Basic rated load (N)		Reference JIS number
					Outer Diameter D2	Position C2	Shield/seal		Dimensions	Quantity (pcs)	Dynamic load Cr	Static load Cor	
							Outer ring Lo	Inner ring Li					
RNR-1350ZZ	5	13	4	0.2	14.8	1.00	11.14	6.66	2.0000	8	1074	422	695ZZNR
RNR-1350DD	5	13	4	0.2	14.8	1.00	11.14	6.66	2.0000	8	1074	422	695DDNR
LNR-1360X3ZZ	6	13	5	0.15	14.5	1.10	11.44	7.33	2.0000	8	1083	438	686ZZNR
RNR-1560ZZ	6	15	5	0.2	17.2	1.50	13.20	7.80	2.7781	7	1735	671	696ZZNR
RNR-1560DD	6	15	5	0.2	17.2	1.50	13.20	7.80	2.7781	7	1735	671	696DDNR
RNR-1760X2ZZ	6	17	6	0.3	19.2	1.20	14.70	8.22	3.5000	6	2265	839	606ZZNR
RNR-1760X2DD	6	17	6	0.3	19.2	1.20	14.70	8.22	3.5000	6	2265	839	606DDNR
626ZZNR	6	19	6	0.3	22.1	1.50	16.68	9.20	3.5000	7	2614	1053	626ZZNR
626DDNR	6	19	6	0.3	22.1	1.50	16.68	9.20	3.5000	7	2614	1053	626DDNR
RNR-4KK	6.350	15.875	4.978	0.3	18.5	1.80	13.04	8.20	2.3813	8	1470	599	-
LNR-1680KK	8	16	5	0.2	18.2	0.95	14.18	9.68	2.3813	9	1606	712	-
LNR-1680DD	8	16	5	0.2	18.2	0.95	14.18	9.68	2.3813	9	1606	712	-
608ZZNRSD06	8	22	7	0.3	25.1	2.30	19.10	10.80	3.9688	7	3297	1368	608ZZNR
608DDNRSD06	8	22	7	0.3	25.1	2.30	19.10	10.80	3.9688	7	3297	1368	608DDNR
RNR-2210X9KKSD21	10	22	6	0.3	24.7	1.62	19.40	13.40	3.1750	9	2697	1273	6900ZZNR
RNR-2412X3KK	12	24	6	0.3	26.8	1.62	21.69	14.28	3.5719	8	3082	1433	6901ZZNR

Thrust ball bearings

Metric size: Basic (stainless steel)

Note: The tolerance of thrust ball bearings does not conform to JIS. Contact us for dimensional tolerances.

T-DSG Series

Inner diameter: 3mm to 10mm

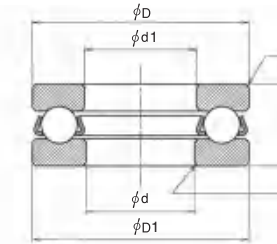

Grooved

(Unit: mm)

Part number	Main dimensions						Chamfer C	Ball		Basic rated load (N)	
	Inner diameter d +0 -0.008	Inner diameter d1 ±0.05	Outer diameter D +0 -0.011	Outer diameter D1 +0 -0.05	Height T +0 -0.075	Dimensions		Quantity (pcs)	Dynamic load Ca	Static load Coa	
DDT-830DSG	3	3.1	8	8	3.5	0.2	2.0000	7	1788	1725	
DDT-940DSG	4	4.1	9	9	4	0.2	2.0000	8	1859	1972	
DDT-1040DSG	4	4.1	10	10	4.5	0.2	2.0000	9	1926	2218	
DDT-1050DSG	5	5.1	10	10	4	0.2	2.0000	9	1926	2218	
DDT-1260DSG	6	6.2	12	12	4.5	0.2	2.0000	9	1824	2218	
DDT-1570DSG	7	7.2	15	15	5.5	0.3	2.3813	9	2476	3144	
DDT-1680X2DSG	8	8.2	16	16	5	0.3	3.0000	9	3918	4990	
DDT-1790DSG	9	9.2	17	17	5	0.3	3.0000	9	1633	2218	
DDT-1810DSG	10	10.2	18	18	5.5	0.3	3.1750	12	5119	7452	

No groove

(Unit: mm)

Part number	Main dimensions				Ball	
	Inner diameter d +0.040 +0.020	Outer diameter D +0 -0.011	Height T +0 -0.075	Chamfer C	Dimensions	Quantity (pcs)
DDT-830	3	8	3.5	0.2	1.1906	7
DDT-940	4	9	4.0	0.2	1.1906	8
DDT-1150	5	11	4.5	0.2	1.5875	8
DDT-1260	6	12	4.5	0.2	1.5875	9
DDT-1570	7	15	5.0	0.3	2.0000	7
DDT-1680	8	16	5.0	0.3	2.0000	8
DDT-1790	9	17	5.0	0.3	2.0000	9
DDT-1810	10	18	5.5	0.3	2.3813	9

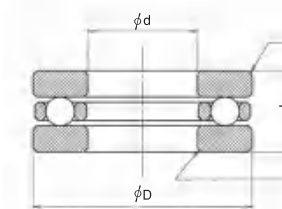

Radial deep groove ball bearings

Inch size: Basic (chrome steel, stainless steel)

RI- Series (R- Series)

Inner diameter: 1.0160mm to 19.0500mm

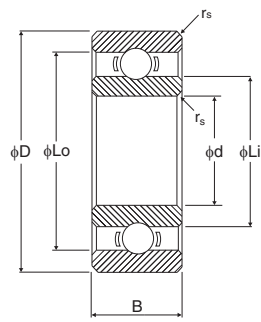

Open type
Radial Open Ball Bearings

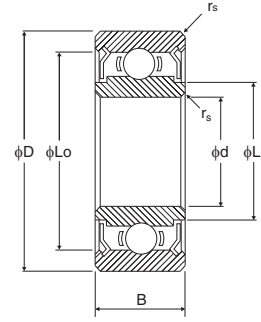

Shielded
Radial Shielded Ball Bearings

(Unit: mm)

Part number ^{Note}	Inner diameter d	Outer diameter D	Width B	Chamfer r_s min.	Shoulder diameter		Ball		Basic rated load (N)	
					Outer ring Lo	Inner ring Li	Dimensions	Quantity (pcs)	Dynamic load	Static load
									Cr	Cor
DDRI-2X2	1.016	3.175	1.191	0.08	2.56	1.64	0.6350	6	106	28
DDRI-2 1/2	1.191	3.967	1.588	0.08	3.16	2.05	0.7938	6	158	44
DDRI-2 1/2ZZ	1.191	3.967	2.380	0.08	3.43	2.05	0.7938	6	158	44
DDRI-3	1.397	4.762	1.984	0.08	4.02	2.36	1.1906	5	264	71
DDRI-3ZZ	1.397	4.762	2.779	0.08	4.29	2.36	1.1906	5	264	71
DDRI-4	1.984	6.350	2.380	0.08	4.90	3.10	1.1906	6	330	99
DDRI-4ZZ	1.984	6.350	3.571	0.08	5.23	3.10	1.1906	6	330	99
DDRI-3332	2.380	4.762	1.588	0.08	4.13	3.00	0.7938	7	187	59
DDRI-3332ZZ	2.380	4.762	2.380	0.08	4.28	3.00	0.7938	7	187	59
DDRI-5	2.380	7.938	2.779	0.08	6.88	4.40	1.5875	6	563	183
DDRI-5ZZ	2.380	7.938	3.571	0.08	7.19	4.40	1.5875	6	563	183
DDRI-418	3.175	6.350	2.380	0.08	5.52	4.10	1.0000	7	285	97
DDRI-418ZZ	3.175	6.350	2.779	0.08	5.85	4.10	1.0000	7	285	97
DDRI-518	3.175	7.938	2.779	0.08	6.88	4.40	1.5875	6	563	183
DDRI-518ZZ	3.175	7.938	3.571	0.08	7.19	4.40	1.5875	6	563	183
DDR-2	3.175	9.525	3.967	0.3	7.65	5.08	1.5875	7	641	226
DDR-2ZZ	3.175	9.525	3.967	0.3	8.19	5.08	1.5875	7	641	226
R-2KK1	3.175	9.525	3.967	0.3	8.22	5.20	1.5875	7	641	226
R-2DD	3.175	9.525	3.967	0.3	7.89	4.68	1.5875	7	641	226
DDRI-618	3.175	9.525	2.779	0.13	6.88	4.40	1.5875	6	563	183
DDRI-618ZZ	3.175	9.525	3.571	0.13	7.20	4.40	1.5875	6	563	183
DDRI-5532	3.967	7.938	2.779	0.08	7.08	5.62	1.1906	7	391	142
DDRI-5532ZZ	3.967	7.938	3.175	0.08	7.31	5.62	1.1906	7	391	142
DDRI-5632	4.762	7.938	2.779	0.08	7.08	5.62	1.1906	7	391	142
DDRI-5632ZZ	4.762	7.938	3.175	0.08	7.31	5.62	1.1906	7	391	142
DDRI-6632	4.762	9.525	3.175	0.08	8.72	5.97	1.5875	8	712	271
DDRI-6632ZZ	4.762	9.525	3.175	0.08	8.68	5.97	1.5875	8	712	271

Note: White columns are chrome steel and blue columns are stainless steel.

(Unit: mm)

Part number ^{Note}	Inner diameter d	Outer diameter D	Width B	Chamfer r_s min.	Shoulder diameter		Ball		Basic rated load (N)	
					Outer ring Lo	Inner ring Li	Dimensions	Quantity (pcs)	Dynamic load	Static load
									Cr	Cor
RI-6632ZZ	4.762	9.525	3.175	0.08	8.72	5.97	1.5875	8	712	271
DDR-3	4.762	12.700	3.967	0.3	10.49	7.00	2.3813	7	1306	487
DDR-3ZZ	4.762	12.700	4.978	0.3	11.00	7.00	2.3813	7	1306	487
R-3HH	4.762	12.700	4.978	0.3	11.04	7.00	2.3813	7	1306	487
R-3DD	4.762	12.700	4.978	0.3	11.04	7.00	2.3813	7	1306	487
DDRI-614	6.350	9.525	3.175	0.08	8.63	7.25	1.0000	13	417	205
DDRI-614ZZ	6.350	9.525	3.175	0.08	8.88	7.25	1.0000	13	417	205
DDRI-814	6.350	12.700	3.175	0.13	10.98	8.38	1.5875	10	828	374
DDRI-814ZZ	6.350	12.700	4.762	0.13	11.55	8.38	1.5875	10	828	374
RI-814ZZ	6.350	12.700	4.762	0.13	11.55	8.38	1.5875	10	828	374
DDR-4	6.350	15.875	4.978	0.3	13.03	8.20	2.3813	8	1470	599
DDR-4HH	6.350	15.875	4.978	0.3	13.03	8.20	2.3813	8	1470	599
DDR-4SS	6.350	15.875	4.978	0.3	13.03	8.20	2.3813	8	1470	599
R-4KK	6.350	15.875	4.978	0.3	13.03	8.20	2.3813	8	1470	599
R-4DD	6.350	15.875	4.978	0.3	13.03	8.20	2.3813	8	1470	599
R-4SS	6.350	15.875	4.978	0.3	13.03	8.20	2.3813	8	1470	599
DDRI-1214	6.350	19.050	5.558	0.41	15.19	9.80	3.5719	6	2411	912
DDRI-1214ZZ	6.350	19.050	7.142	0.41	16.28	8.63	3.5719	6	2411	912
RI-1214ZZ	6.350	19.050	7.142	0.41	16.28	8.63	3.5719	6	2411	912
DDRI-8516	7.938	12.700	3.967	0.13	11.44	9.20	1.5875	11	878	419
DDRI-8516ZZ	7.938	12.700	3.967	0.13	11.77	9.20	1.5875	11	878	419
DDRI-1038	9.525	15.875	3.967	0.25	13.78	11.63	1.5875	12	906	477
DDRI-1038ZZ	9.525	15.875	3.967	0.25	14.16	11.63	1.5875	12	906	477
DDRI-1438	9.525	22.225	5.558	0.41	18.83	13.22	3.9688	7	3297	1368
DDRI-1438ZZ	9.525	22.225	7.142	0.41	19.89	12.05	3.9688	7	3297	1368
RI-1438	9.525	22.225	5.558	0.41	18.00	12.40	3.9688	7	3297	1368
RI-1438KK	9.525	22.225	7.142	0.41	19.10	12.40	3.9688	7	3297	1368
RI-1438DD	9.525	22.225	7.142	0.41	19.10	12.40	3.9688	7	3297	1368
RI-1438SS	9.525	22.225	7.142	0.41	19.10	12.40	3.9688	7	3297	1368
DDRI-1812	12.700	28.575	6.350	0.41	23.20	17.80	3.9688	9	4033	2003
DDRI-1812ZZ	12.700	28.575	7.938	0.41	24.54	15.93	3.9688	9	4033	2003
RI-1812KK	12.700	28.575	7.938	0.41	25.13	16.00	4.7625	8	5113	2387
DDRI-1212ZZ	12.700	19.050	3.967	0.25	17.49	14.90	1.5875	16	1051	662
DDRI-1458ZZ	15.875	22.225	3.967	0.25	20.69	18.10	1.5875	18	1093	742
DDRI-1634	19.050	25.400	3.967	0.25	23.84	21.25	1.5875	22	1203	894
DDRI-1634ZZ	19.050	25.400	3.967	0.25	23.84	21.25	1.5875	22	1203	894

Note: White columns are chrome steel and blue columns are stainless steel.

Radial deep groove ball bearings

Inch size: With flange (chrome steel, stainless steel)

RIF- Series

Inner diameter: 1.0160mm to 9.5250mm

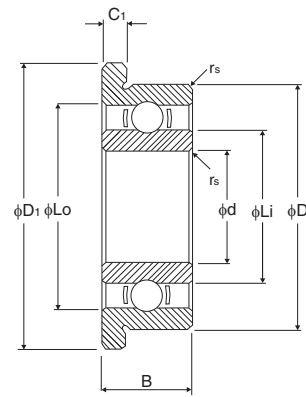

Open type
Radial Flanged Open Ball Bearings

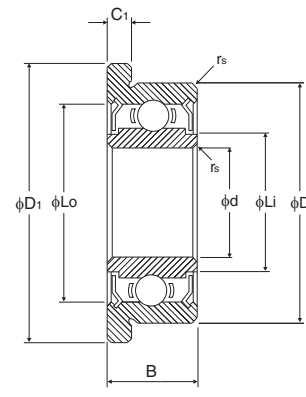

Shielded
Radial Flanged Shielded Ball Bearings

(Unit: mm)

Part number ^{Note}	Inner diameter d	Outer diameter D	Width B	Chamfer r_s min.	Flange		Shoulder diameter		Ball	Basic rated load (N)			
					Outer diameter D1	Width C1	Outer ring Lo	Inner ring Li		Dimensions	Quantity (pcs)	Dynamic load Cr	Static load Cor
DDRIF-2X2	1.016	3.175	1.191	0.08	4.343	0.33	2.56	1.64	0.6350	6	106	28	
DDRIF-2 1/2	1.191	3.967	1.588	0.08	5.156	0.33	3.16	2.05	0.7938	6	158	44	
DDRIF-2 1/2ZZ	1.191	3.967	2.380	0.08	5.156	0.79	3.43	2.05	0.7938	6	158	44	
DDRIF-3	1.397	4.762	1.984	0.08	5.944	0.58	4.02	2.36	1.1906	5	264	71	
DDRIF-4	1.984	6.350	2.380	0.08	7.518	0.58	4.90	3.10	1.1906	6	330	99	
DDRIF-4ZZ	1.984	6.350	3.571	0.08	7.518	0.79	5.23	3.10	1.1906	6	330	99	
DDRIF-3332	2.380	4.762	1.588	0.08	5.944	0.46	4.13	3.00	0.7938	7	187	59	
DDRIF-3332ZZ	2.380	4.762	2.380	0.08	5.944	0.79	4.28	3.00	0.7938	7	187	59	
DDRIF-5	2.380	7.938	2.779	0.08	9.119	0.58	6.88	4.40	1.5875	6	563	183	
DDRIF-5ZZ	2.380	7.938	3.571	0.08	9.119	0.79	7.19	4.40	1.5875	6	563	183	
DDRIF-418	3.175	6.350	2.380	0.08	7.518	0.58	5.52	4.10	1.0000	7	285	97	
DDRIF-418ZZ	3.175	6.350	2.779	0.08	7.518	0.79	5.85	4.10	1.0000	7	285	97	
DDRIF-518	3.175	7.938	2.779	0.08	9.119	0.58	6.88	4.40	1.5875	6	563	183	
DDRIF-518ZZ	3.175	7.938	3.571	0.08	9.119	0.79	7.19	4.40	1.5875	6	563	183	
DDRF-2	3.175	9.525	3.967	0.3	11.176	0.76	7.65	5.08	1.5875	7	641	226	
DDRF-2ZZ	3.175	9.525	3.967	0.3	11.176	0.76	8.19	5.08	1.5875	7	641	226	
DDRIF-618	3.175	9.525	2.779	0.13	10.719	0.58	6.88	4.40	1.5875	6	563	183	
DDRIF-618ZZ	3.175	9.525	3.571	0.13	10.719	0.79	7.20	4.40	1.5875	6	563	183	

(Unit: mm)

Part number ^{Note}	Inner diameter d	Outer diameter D	Width B	Chamfer r_s min.	Flange		Shoulder diameter		Ball	Basic rated load (N)			
					Outer diameter D1	Width C1	Outer ring Lo	Inner ring Li		Dimensions	Quantity (pcs)	Dynamic load Cr	Static load Cor
DDRIF-5532ZZ	3.967	7.938	3.175	0.08	9.119	0.91	7.31	5.62	1.1906	7	391	142	
DDRIF-5632	4.762	7.938	2.779	0.08	9.119	0.58	7.08	5.62	1.1906	7	391	142	
DDRIF-5632ZZ	4.762	7.938	3.175	0.08	9.119	0.91	7.31	5.62	1.1906	7	391	142	
DDRIF-6632	4.762	9.525	3.175	0.08	10.719	0.58	8.72	5.97	1.5875	8	712	271	
DDRIF-6632ZZ	4.762	9.525	3.175	0.08	10.719	0.79	8.68	5.97	1.5875	8	712	271	
DDRF-3	4.762	12.700	3.967	0.3	14.351	1.07	10.49	7.00	2.3813	7	1306	487	
DDRF-3ZZ	4.762	12.700	4.978	0.3	14.351	1.07	11.00	7.00	2.3813	7	1306	487	
DDRIF-614	6.350	9.525	3.175	0.08	10.719	0.58	8.63	7.25	1.0000	13	417	205	
DDRIF-614ZZ	6.350	9.525	3.175	0.08	10.719	0.91	8.88	7.25	1.0000	13	417	205	
DDRIF-814	6.350	12.700	3.175	0.13	13.894	0.58	10.98	8.38	1.5875	10	828	374	
DDRIF-814ZZ	6.350	12.700	4.762	0.13	13.894	1.14	11.55	8.38	1.5875	10	828	374	
DDRF-4HH	6.350	15.875	4.978	0.3	17.526	1.07	13.04	8.20	2.3813	8	1470	599	
RF-4HH	6.350	15.875	4.978	0.3	17.526	1.07	13.04	8.20	2.3813	8	1470	599	
DDRIF-8516	7.938	12.700	3.967	0.13	13.894	0.79	11.44	9.20	1.5875	11	878	419	
DDRIF-8516ZZ	7.938	12.700	3.967	0.13	13.894	0.79	11.77	9.20	1.5875	11	878	419	
DDRIF-1438ZZ	9.525	22.225	7.142	0.41	24.613	1.57	19.89	12.05	3.9688	7	3297	1368	
RIF-1438KK	9.525	22.225	7.142	0.41	24.613	1.58	19.10	12.40	3.9688	7	3297	1368	
RIF-1438DD	9.525	22.225	7.142	0.41	24.613	1.58	19.10	12.40	3.9688	7	3297	1368	

Note: White columns are chrome steel and blue columns are stainless steel.

3 Other Products

MinebeaMitsumi manufactures various assembly products in addition to radial ball bearings. They are made to order according to customer requirements.

1 Pivot assembly



MinebeaMitsumi's precision processing technology and advanced assembly technology enable a long life, low torque, and high precision, ease of manufacturing. It is a product that integrates advanced technologies created by continuous research - thorough quality control in response to the demands for high-density and high-speed HDDs. The material for manufacturing can be stainless steel, aluminum and other special materials. It is also possible to produce composite assemblies using this pivot assembly.

3 Pulley



MinebeaMitsumi pulley has a structure in which pulleys of various materials and shapes are assembled by methods such as press-fitting, bonding and molding into the outer ring of a miniature ball bearing. We adopt high-precision in-house bearings to achieve high quality and low cost.

2 Tape guide



A high-precision tape guide using MinebeaMitsumi miniature ball bearings that has been developed through MinebeaMitsumi's advanced technology and know-how. The tape running members can be made of various materials such as non-magnetic aluminum, SUS303 and resin. The standard tape width is 4 mm to 25.4 mm, but special sizes can also be manufactured.

4 Special assembly



Various types of bearing assembly products can be manufactured using high-precision MinebeaMitsumi miniature ball bearings. Utilizing MinebeaMitsumi's precision processing technology and know-how of bearing assemblies, high precision and high quality are achieved.

4 Terminology

1. Standard terminology

ISO	International Organization for Standardization
JIS	Japanese Industrial Standards
ANSI	American National Standards Institute
SAE	Society of Automotive Engineers
MIL	Military Standard
ASTM	American Society for Testing and Materials
ABMA	American Bearing Manufacturers Association
BAS	The Japan Bearing Industrial Association Standards

2. Bearing components

Rolling ball bearing	Bearing that functions in rolling motion using balls as rolling elements
Raceway ring	Annular parts (inner and outer rings) with running paths (raceway) on which balls roll
Outer Ring	Raceway ring with a track on the inner surface, usually placed in a housing
Inner Ring	Raceway ring with a track on the outer surface through which a normal shaft passes
Ball	Spherical rolling element
Retainer	Parts that keep balls at equal intervals on revolving orbit
Seal	Rubber annular lid that prevents lubricant leakage or intrusion of foreign matter
Shield	Metallic annular lid that prevents intrusion of foreign matter
Snap Ring	C-type snap ring that fixes the shield

3. Dimensions/tolerance

Nominal outer diameter	Outer ring outer diameter (bearing outer diameter) Reference value for actual outer diameter dimensional difference
Nominal inner diameter	Inner ring inner diameter (bearing bore) Reference value for actual inner diameter dimensional difference
Pitch circle diameter	Ball (rolling element) revolving orbit diameter
Radial runout	Radial runout of raceway ring
Axial runout	Axial runout of raceway ring
Inequality of width	Difference between maximum and minimum widths of one raceway ring

4. Lubricants

Grease	Semi-solid lubricant with lubricating oil as base oil and thickener dispersed
Viscosity	Scale of the viscosity of lubricating oil
Consistency	Scale of grease hardness
Thickener	For holding base oil and maintaining grease in semi-solid state
Drop point	Temperature at which grease melts and drips
Oil separation	Degree of separation of base oil
Soap	Used as thickener
Base oil	Oil for base lubrication
Oil film	Oil film formed between ball and raceway
Channeling type and churning type	When the grease is sealed in the bearing and rotated, and the grease in the raceway is separated by the passage of the rolling element, there is a type in which the grease tends to stay as it is separated and a type in which the grease easily spreads through the surface of the rolling element and raceway The former is called a channeling type and the latter is called a churning type

5. Applications and usage

Preload	Axial load applied to bearings in advance to increase rigidity and reduce runout and impact
Radial load	Radial load
Axial load	Axial load
Life	Total rotation speed or time until it no longer functions as a bearing
Maximum rotation speed	Limit speed determined by bearing design
Fits	Combining shaft and inner ring inner diameter, and housing and outer ring outer diameter
dmn value	Product of pitch circle diameter and rotation speed
NRRO	Non-repetitive runout
Starting torque	Torque at the start of bearing rotation (starting torque)
Running torque	Torque during bearing rotation
Rigidity	Deformation strength by load
Inherent vibration	For a ball bearing, the vibration where the ball works as spring
Vibration frequency	Vibration generated when rotating bearings
Cogging	Bearing startup resistance (catch)
Subside amount	The width of the part where the inner and outer rings overlap in the preloaded state
Contact pressure	Load per unit area at contact point between ball and track surface
Composite load	Combined load of radial and axial loads
Misalignment	Errors in incorporating bearings into equipment

6. Damage

Rolling trace	Trace of ball rolling on raceway
Indentation	Trace of plastic deformation on raceways
Brinelling (Brinell indentation)	Trace of plastic deformation by balls on raceways
Dent	Indentation type
Fretting	Abrasion with oxidation due to micro-vibration (also called pseudo indentation)
Flaking	Raceways peel off in scale-form due to metal fatigue
Creep	Sliding of fit surface
Pitching	Small holes in raceways due to metal fatigue
Smearing	Partial quenching
Electrolysis	Dissolution of surface due to energization (discharge)
Roughness (satin)	Roughness of raceway and ball surface (roughness similar to surface of pear)
Temper color	Discoloration due to high temperature
Croaking sound	Sound similar to frogs (self-excited vibration of the retainer)
Race sound	The sound of balls rolling in raceways
Chemical attack	Phenomenon in which resin material is deteriorated or damaged due to oil

7. Clearance

Radial Clearance	Radial clearance in bearing
Axial Clearance	Axial clearance in bearing
Corner Clearance	Inclination angle of inner ring with outer ring fixed
Residual clearance	Radial clearance after assembling shaft or housing to the bearing (clearance after fitting)
Effective clearance	Residual clearance in consideration of temperature
Operation clearance	Radial clearance during operation
Contact angle	Formed angle between the plane perpendicular to the center axis of the bearing and the action line of the force moving between the raceway ring and ball
Nominal contact angle	Nominal (design) contact angle

8. Other

Contact elastic modulus	Coefficient determined by ball diameter and curvature radius
Contact ellipse	Shape of contact surface between track surface and ball diameter
Curvature radius	Raceway radius
Curvature	Curvature radius to ball diameter ratio

5 Appendix

Inch/metric conversion table

inch	mm	inch	mm	inch	mm	inch	mm
1/64	0.3969	17/64	6.7469	33/64	13.0969	49/64	19.4469
1/32	0.7938	9/32	7.1438	17/32	13.4938	25/32	19.8438
3/64	1.1906	19/64	7.5406	35/64	13.8906	51/64	20.2406
1/16	1.5875	5/16	7.9375	9/16	14.2875	13/16	20.6375
5/64	1.9844	21/64	8.3344	37/64	14.6844	53/64	21.0344
3/32	2.3813	11/32	8.7313	19/32	15.0813	27/32	21.4313
7/64	2.7781	23/64	9.1281	39/64	15.4781	55/64	21.8281
1/8	3.1750	3/8	9.5250	5/8	15.8750	7/8	22.2250
9/64	3.5719	25/64	9.9219	41/64	16.2719	57/64	22.6219
5/32	3.9688	13/32	10.3188	21/32	16.6688	29/32	23.0188
11/64	4.3656	27/64	10.7156	43/64	17.0656	59/64	23.4156
3/16	4.7625	7/16	11.1125	11/16	17.4625	15/16	23.8125
13/64	5.1594	29/64	11.5094	45/64	17.8594	61/64	24.2094
7/32	5.5563	15/32	11.9063	23/32	18.2563	31/32	24.6063
15/64	5.9531	31/64	12.3031	47/64	18.6531	63/64	25.0031
1/4	6.3500	1/2	12.7000	3/4	19.0500	1	25.4000

Temperature Celsius / Fahrenheit Conversion Table

°C	°F	°C	°F
-100	-148	0	32
-90	-130	10	50
-80	-112	20	68
-70	-94	30	86
-60	-76	40	104
-50	-58	50	122
-40	-40	60	140
-30	-22	70	158
-20	-4	80	176
-10	14	90	194
		100	212

Weight conversion table

Newton	Kilogram	Pound
N	kgf	lb
1	0.1020	0.2248
2	0.2039	0.4496
3	0.3059	0.6744
4	0.4079	0.8992
5	0.5099	1.1240
6	0.6118	1.3489
7	0.7138	1.5737
8	0.8158	1.7985
9	0.9177	2.0233
10	1.0197	2.2481
20	2.0394	4.4962
30	3.0591	6.7443
40	4.0789	8.9924
50	5.0986	11.2404
60	6.1183	13.4885
70	7.1380	15.7366
80	8.1577	17.9847
90	9.1774	20.2328
100	10.1972	22.4809

Physical and mechanical properties of metals

Material name	Specific gravity	Linear expansion coefficient 0~100°C ×10 ⁻⁶	Longitudinal modulus GPa	Hardness HBW
SUJ 2	7.83	12.5	207	690
DD400	7.90	10.2	204	650
SUS440C	7.68	10.1	200	580
S25C	7.84	11.8	206	120
S45C	7.83	12.8	207	217
SUS303	8.03	17.3	193	180
SUS304	7.93	16.3	193	150
SUS416	7.75	9.9	200	-
SUS420J2	7.75	10.4	200	400
Brass	8.40	19.1	105	-
Copper	8.90	16.0	130	-
Aluminum	2.69	24.0	70	-
ADC10	2.74	22.0	71	-
FC200	7.30	10.4	105	217
SPCC	7.86	11.7	211	70
Ceramic	3.26	1.5	301	1,470(HV)

Hardness conversion table

HRC	HV	HBW
68	940	
67	900	
66	865	
65	832	(739)
64	800	(722)
63	772	(705)
62	746	(688)
61	720	(670)
60	697	(654)
59	674	(634)
58	653	615
57	633	595
56	613	577
55	595	560
54	577	543
53	560	525
52	544	512
51	528	496
50	513	481
49	498	469
48	484	455
47	471	443
46	458	432
45	446	421
44	434	409

Note 1: The physical property values in the table are for reference purpose and differ depending on the material manufacturer.
 Note 2: SUJ 2, DD400 and SUS440C are usually expressed as HRC, but converted to HBW for comparison purpose.

5 Appendix

Conversion table for major SI units (SI units are shown in bold frame)

Force

N	kgf
1	1.01972×10 ⁻¹
9.80665	1

Stress

Pa or N/m ²	MPa or N/mm ²	kgf/mm ²	kgf/cm ²
1	1×10 ⁻⁶	1.01972×10 ⁻⁷	1.01972×10 ⁻⁵
1×10 ⁶	1	1.01972×10 ⁻¹	1.01972×10
9.80665×10 ⁶	9.80665	1	1×10 ²
9.80665×10 ⁴	9.80665×10 ⁻²	1×10 ⁻²	1

Kinematic viscosity

m ² /s	mm ² /s	cSt	St
1	1×10 ⁶	1×10 ⁶	1×10 ⁴
1×10 ⁻⁶	1	1	1×10 ⁻²
1×10 ⁻⁴	1×10 ²	1×10 ²	1

Pressure

Pa	kPa	MPa	bar	kgf/cm ²	kgf/mm ²	mmH ₂ O	mmHg or Torr
1	1×10 ⁻³	1×10 ⁻⁶	1×10 ⁻⁵	1.01972×10 ⁻⁵	1.01972×10 ⁻⁷	1.01972×10 ⁻¹	7.50062×10 ⁻³
1×10 ³	1	1×10 ⁻³	1×10 ⁻²	1.01972×10 ⁻²	1.01972×10 ⁻⁴	1.01972×10 ²	7.50062
1×10 ⁶	1×10 ³	1	1×10	1.01972×10	1.01972×10 ⁻¹	1.01972×10 ⁵	7.50062×10 ³
1×10 ⁵	1×10 ²	1×10 ⁻¹	1	1.01972	1.01972×10 ⁻²	1.01972×10 ⁴	7.50062×10 ²
9.80665×10 ⁴	9.80665×10	9.80665×10 ⁻²	9.80665×10 ⁻¹	1	1×10 ⁻²	1×10 ⁴	7.35559×10 ²
9.80665×10 ⁶	9.80665×10 ³	9.80665	9.80665×10	1×10 ²	1	1×10 ⁶	7.35559×10 ⁴
9.80665	9.80665×10 ⁻³	9.80665×10 ⁻⁶	9.80665×10 ⁻⁵	1×10 ⁻⁴	1×10 ⁻⁶	1	7.35559×10 ⁻²
1.33322×10 ²	1.33322×10 ⁻¹	1.33322×10 ⁻⁴	1.33322×10 ⁻³	1.35951×10 ⁻³	1.35951×10 ⁻⁵	1.35951×10	1

Torque

N·m	mN·m	μN·m	kgf·cm	gf·cm
1	1×10 ³	1×10 ⁶	1.01972×10	1.01972×10 ⁴
1×10 ⁻³	1	1×10 ³	1.01972×10 ⁻²	1.01792×10
1×10 ⁻⁶	1×10 ⁻³	1	1.01972×10 ⁻⁵	1.01972×10 ⁻²
9.80665×10 ⁻²	9.80665×10	9.80665×10 ⁴	1	1×10 ³
9.80665×10 ⁻⁵	9.80665×10 ⁻²	9.80665×10	1×10 ⁻³	1

SI unit prefix

Multiple	Prefix		Multiple	Prefix	
	Name	Symbol		Name	Symbol
10 ¹⁸	Exa	E	10 ⁻¹	Deci	d
10 ¹⁵	Peta	P	10 ⁻²	Centi	c
10 ¹²	Tera	T	10 ⁻³	Milli	m
10 ⁹	Giga	G	10 ⁻⁶	Micro	μ
10 ⁶	Mega	M	10 ⁻⁹	Nano	n
10 ³	Kilo	k	10 ⁻¹²	Pico	p
10 ²	Hect	h	10 ⁻¹⁵	Femto	f
10	Deca	da	10 ⁻¹⁸	Atto	a

Greek letters

Uppercase	Lowercase	English notation	Kana notation
A	α	alpha	Alpha
B	β	beta	Beta
Γ	γ	gamma	Gamma
Δ	δ	delta	Delta
E	ε	epsilon	Epsilon
Z	ζ	zeta	Zeta
H	η	eta	Eta
Θ	θ	theta	Theta
I	ι	iota	Iota
K	κ	kappa	Kappa
Λ	λ	lambda	Lambda
M	μ	mu	Mu
N	ν	nu	Nu
Ξ	ξ	xi	Xi
O	ο	omicron	Omicron
Π	π	pi	Pi
P	ρ	rho	Rho
Σ	σ	sigma	Sigma
T	τ	tau	Tau
Υ	υ	upsilon	Upsilon
Φ	φ	phi	Phi
X	χ	chi	Chi
Ψ	ψ	psi	Psi
Ω	ω	omega	Omega

Measuring machine



Anderson meter



Roundness measuring machine



Air micrometer



Surface roughness measuring machine



Rotational viscometer



Oil film thickness measuring machine



Scanning electron microscope



3D microscope



X-ray stress measuring device

Analyzing machine



Liquid chromatograph



Thermal analyzing machine



Ion chromatograph



Fluorescence X-ray analyzing machine



Fourier transform infrared spectrometer



Gas chromatograph

Environmental equipment



Constant temperature bath



Anechoic chamber

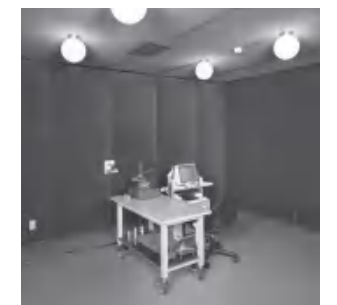

Soundproof room



Salt water spray test device



Four-ball testing machine



JSPS life tester

List of domestic sales offices

MinebeaMitsumi, Inc

Tokyo Office

(Customer Service Center, Tokyo Customer Group)
 〒108-8330
 3-9-6 Mita, Minato-ku, Tokyo
 TEL: 03-6758-6748/FAX: 03-6758-6760

Nagoya Office

(Customer Service Center, Nagoya Customer Group)
 〒460-0003
 4F Nagoya Nishiki City Building, 1-6-5 Nishiki, Naka-ku,
 Nagoya-shi, Aichi
 TEL: 052-231-1181/FAX: 052-231-1157

Osaka Office

(Customer Service Center, Osaka Customer Group)
 〒541-0053
 11F WAKITA Sakaisuji Honmachi Building, 1-7-7 Hon-cho,
 Chuo-ku, Osaka-shi, Osaka
 TEL: 06-6263-8331/FAX: 06-6263-7388

Sales Division

Marketing Department
 〒108-8330
 3-9-6 Mita, Minato-ku, Tokyo
 TEL: 03-6758-6746/FAX: 03-6758-6760

NMB Sales Co., Ltd.

Head office

〒101-0032
 7F Itopia Iwamotocho 1-chome Building, 1-8-15 Iwamoto-cho,
 Chiyoda-ku, Tokyo
 TEL: 03-5835-0371/FAX: 03-5835-0370

Nagoya Sales Office

〒460-0003
 4F Nagoya Nishiki City Building, 1-6-5 Nishiki, Naka-ku,
 Nagoya-shi, Aichi
 TEL: 052-205-8841/FAX: 052-231-1157

Osaka Sales Office

〒541-0053
 11F WAKITA Sakaisuji Honmachi Building, 1-7-7 Hon-cho,
 Chuo-ku, Osaka-shi, Osaka
 TEL: 06-6260-7061/FAX: 06-6263-7388

List of overseas sales offices

(Asia)

Thailand

NMB-MinebeaMitsumi Thai Ltd. Bangkok Office
 19th Floor, Wave Place Building, 55 Wireless Road,
 Lumpinee Pathumwan, Bangkok, 10330 Thailand
 TEL: 66-2-253-4897/FAX: 66-2-255-2875/66-2-253-4537

Singapore

NMB Singapore Ltd. Chai Chee Factory
 1, Chai Chee Avenue, Singapore 469059
 TEL: 65-6278-8522/FAX: 65-6278-8477

China

MinebeaMitsumi Trading (Shanghai) Ltd.
 Room 1120, Waigaoqiao Building, No.6 Jilong Road,
 Waigaoqiao Free Trade Zone, Shanghai, China
[Shanghai Branch]
 1010, Huaihai Zhong Road, Room 303, K.Wah Centre,
 Huangpu District, Shanghai, 200031, China
 TEL: 86-21-5405-0707/FAX: 86-21-5404-7007

MinebeaMitsumi (Shenzhen) Ltd.

23/F, Tower B, Kingkey 100, No.5016 Shennan Road East,
 Luohu District, Shenzhen 518008, China
 TEL: 86-755-82668846/FAX: 86-755-82668W3~82668844

MinebeaMitsumi Technologies Taiwan Co., Ltd. Taipei Branch

8F, 28 Ching-Cheng Street. Taipei, Taiwan 105,
 China (Tong Tai Business Building)
 TEL: 886-2-2718-2363/FAX: 886-2-2718-4092

South Korea

NMB Korea Co., Ltd.
 7F. JEI Bldg, 253-1, Seohyeon-Dong, Bundang-Gu, Seongnam-Si,
 Gyeonggi-Do, 463-824 Korea
 TEL: 82-2-557-4467/FAX: 82-2-557-4478

Malaysia

MinebeaMitsumi Co., Ltd. Kuala Lumpur Branch
 E407, 4th Floor, East Tower Wisma Consplant 1,
 No. 2 Jalan SS 16/4 47500
 Subang Jaya Selangor Darul Ehsan, Malaysia
 TEL: 60-3-5631-7849 to 52/FAX: 60-3-5631-7844
[Penang Office]
 Suite: 11-H Menara Northam 55,
 Jalan Sultan Ahmad Shah 10050 Penang, Malaysia
 TEL: 60-4-2275681/FAX: 60-4-2275820

Philippines

NMB-MinebeaMitsumi Thai Ltd. Manila Office
 Unit 908-909 Tower One, Ayala Triangle, Ayala Avenue,
 Makati City, Philippines
 TEL: 63-2-856-1395/FAX: 63-2-813-2159

India

NMB-MinebeaMitsumi India Private Limited
[Head Office]
 Level-6, Regus, JMD Regent Square, M.G.Road,
 Gurgaon - 122022, Haryana, India
 TEL: 91-124-329-1333/FAX: 91-124-471-2001
[Chennai Office]
 Level-2, Regus, ALTIUS Block, Olympia Tech. Park Guindy,
 Chennai - 600032, India
 FAX: 91-44-4299-4300
[Pune Office]
 Level-2, Regus, Connaught Place,
 Bund Garden Road, Pune - 411001
 Maharashtra, India
 FAX: 91-20-4014-7576

Vietnam

Representative Office of NMB-MinebeaMitsumi Thai Ltd, in Hanoi
 Room No.903, 9th Floor, Sun Red River Building,
 No.23 Phan Chu Trinh, Hoan Kiem district, Hanoi, Vietnam
 TEL: 84-43-974-4582/FAX: 84-43-974-4587

(North and South America / Europe)

USA

NMB Technologies Corporation
 9730 Independence Avenue, Chatsworth, California 91311, U.S.A.
 TEL: 1-818-341-3355/FAX: 1-818-341-8207

NMB Technologies Corporation Novi Office

39830 Grand River Ave. Suite B-1A, Novi, Michigan 48375, U.S.A.
 TEL : +1-248-919-2255

Brazil

NMB-MinebeaMitsumi do Brasil Importação e Comércio de Componentes
 de Precisão Ltda
 Rua Coronel Oscar Porto, nº 736, 5º andar, sala 53,
 Bairro Paraíso, São Paulo, SP, CEP 04003-003 . Brasil
 TEL: 55-11-3939-0882

UK

NMB-MinebeaMitsumi UK LTD. Bracknell office
 Suite 2.2 Doncastle House, Doncastle Road, Bracknell,
 RG12 8PE, U.K.
 TEL: 44-1344-42-6611/FAX: 44-1344-48-5522

Germany

NMB-MinebeaMitsumi-GmbH
 Siemens Str. 30, D-63225 Langen, Germany
 TEL: 49-6103-913-0/FAX: 49-6103-913-220

Italy

NMB Italia S.r.L.
 Via A. Grandi. 39-41, 20017 Mazzo Di Rho, Milan, Italy
 TEL: 39-02-939711/FAX: 39-02-939-01154

France

NMB MinebeaMitsumi S.a.r.l.
 5, Avenue des Bosquets, Les Ponts de Baillet, 95560,
 Baillet en France, France
 TEL: 33-1-34083939/FAX: 33-1-34083930



MinebeaMitsumi

For technical inquiries:

Bearing Supervisory Department
Sales Promotion Department, Sales Technology Division

〒 108-8330

3-9-6 Mita, Minato-ku, Tokyo

TEL 03-6758-6772

FAX 03-6758-6760

MinebeaMitsumi Homepage
<http://www.MinebeaMitsumi.co.jp/>



● Handling