

# Bearings for Pumps & Compressors

NSK high performance rolling element bearings for pumps and compressors deliver reliable and energy efficient operation with long life.

**Choose  
NSK**

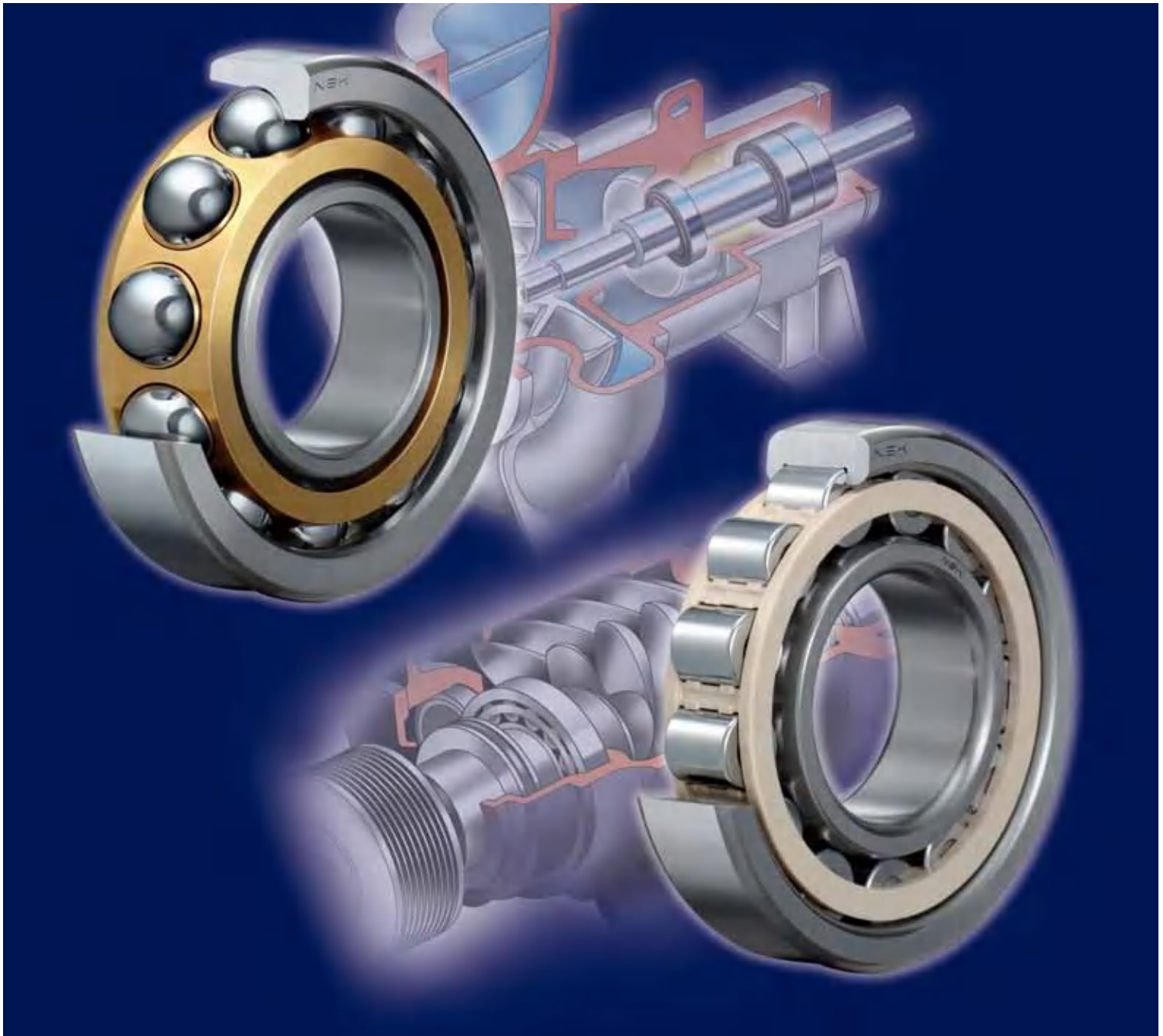

# NSK is the world leader in manufacturing rolling element bearings for every type of pump and compressor.

As the world leader in rolling element bearings, NSK has a reputation for exceeding the most detailed and demanding industrial requirements. NSK's advanced technologies are fully incorporated into bearings developed specifically for pumps and compressors. With an extensive lineup that accommodates any kind of fluid machinery, NSK continues to deliver pump and compressor bearings that feature outstanding reliability, energy saving performance, and excellent resistance to adverse environmental conditions.

Solution Provider NSK

Pump				
Main industries	Petroleum and Chemical (API)	Paper and Pulp (ANSI)	Water/Sewage and Irrigation (underwater)	Liquid Crystal (vacuum)
Recommended bearings				
HPS angular contact ball bearings (machined cage)	● P.7	● P.7		
High load capacity double-row angular contact ball bearings		● P.8	● P.8	
High load capacity deep groove ball bearings (open type)	● P.9	● P.9		● P.9
Creep-free bearings			● P.10	

Compressor				
Main applications	Refrigeration and Air Conditioning		Air and Gas (lubrication)	Air (oil-free)
	Scroll	Screw	Screw	Screw
Recommended bearings				
High load capacity cylindrical roller bearings (L-PPS cage)	● P.15	● P.15	● P.15	
HPS angular contact ball bearings (L-PPS cage)		● P.17	● P.17	
High-speed cylindrical roller bearings				● P.18
High-speed angular contact ball bearings				● P.18

## NSK is on the move, across the globe

- Headquarters**
    - Japan
      - Tokyo
  - North and South America**
    - Ann Arbor
  - Europe**
    - Maidenhead
  - Asia**
    - Shanghai
    - Bangkok
- Plants**
    - Japan
      - Fujisawa
    - Asia
      - Otsu
      - Ishibe
      - Saitama
      - Matsukawa
      - Fukushima
      - Takasaki
      - Haruna
    - North America
      - Clarinda
      - Franklin
      - Liberty
    - South America
      - Suzano
    - Europe
      - Newark
      - Peterlee
      - Munderkingen
      - Turin
      - Kielce
  - Technical offices**
    - Japan
      - Fujisawa
      - Maebashi
      - Aichi
    - North and South America
      - Ann Arbor
      - Suzano
    - Europe
      - Newark
      - Ratingen
      - Kielce
    - Asia
      - Kunshan
      - Changwon
      - Chonburi
  - Sales offices**
    - Japan
      - Tokyo
      - Nagoya
      - Osaka etc.
    - North America
      - Ann Arbor
      - Miami
      - Mississauga
      - Montreal
      - Vancouver
      - Mexico City
    - South America
      - Sao Paul
      - Belo Horizonte
      - Joinville
      - Porto Alegre
      - Recife
      - Buenos Aires
    - Europe
      - Newark
      - Ratingen
      - Kielce
    - Asia
      - Jakarta
      - Bangkok
      - Chonburi
      - Balakong
      - Kunshan
      - Changshu
      - Zhangjiagang
      - Suzhou
      - Hangzhou
      - Changwon
      - Chennai
    - Total 21 sites
  - Europe**
    - Newark
    - Ratingen
    - Stuttgart
    - Paris
    - Milan
    - Turin
    - Barcelona
    - Kielce
    - Warsaw
    - Istanbul
  - Asia**
    - Singapore
    - Jakarta
    - Bangkok
    - Chonburi
    - Kuala Lumpur
    - Ipoh
    - Johor Bahru
    - Prai
    - Beijing
    - Chengdu
    - Guangzhou
    - Shanghai
    - Kunshan
    - Changshu
    - Changchun
    - Chongqing
    - Hong Kong
    - Taichung
    - Tainan
    - Seoul
    - Young-Nam
    - Hanoi
    - Chennai
    - Gurgaon
    - Mumbai
    - Kolkata
  - Oceania**
    - Melbourne
    - Brisbane
    - Perth
    - Sydney
    - Auckland
  - Africa**
    - Johannesburg

# Bearing technologies for Pumps and Compressors

Featuring long life with outstanding efficiency and reliability, NSK bearings for pumps and compressors are ideal for all applications.

**Long life reduces operating costs**  
Optimized internal design and unique material technology extends operating life to 90% longer than conventional bearings, thereby also reducing running costs.

**Improved maximum rotational speed enables high-speed machine operation**  
Precise machining and manufacturing technology provides maximum rotational speed from 15% to 20% faster than conventional bearings, which enables high-speed machine operation and improves working efficiency.

**High performance cages enhance machine reliability**  
Three types of cages to improve machine reliability: high heat-resistant Nylon 46, L-PPS with outstanding oil and chemical resistance, and machined brass.

**Product development minimizes environmental impact**  
NSK minimizes environmental impact throughout the product life cycle, from research and development and design to manufacture, use, and disposal. NSK products are well-suited for both people and the environment.

Impeller clearance controlled by pump bearings.

## NSKHPS Angular Contact Ball Bearings – Highly Efficient Standard for Industrial Machines

# NSKHPS



### High performance

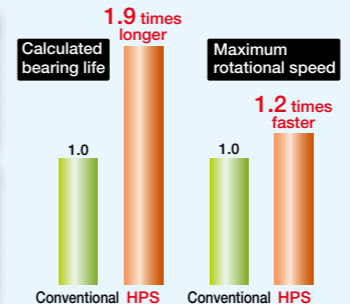
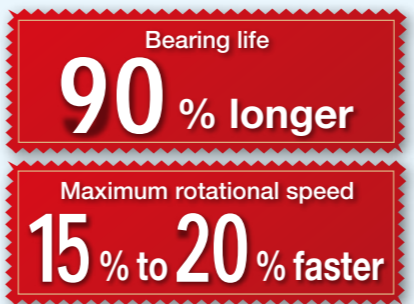

### High accuracy

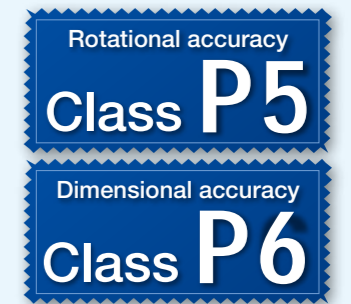

### Universal arrangement

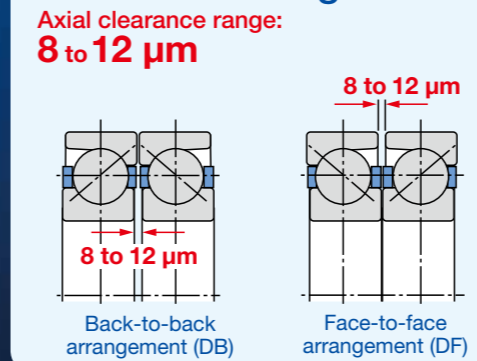

### Features and heat resistance of cage material

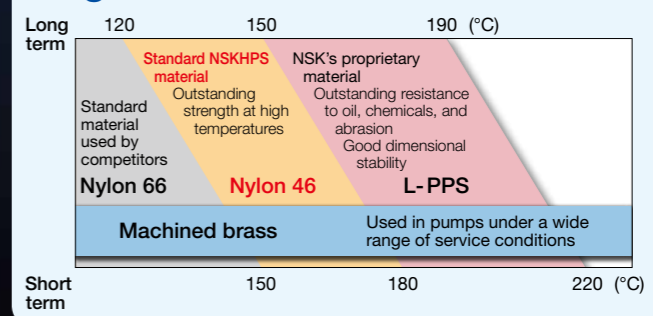

# Bearings for Pumps

Advanced machined brass cage provide strength and endurance. Optimized internal geometries allow efficient lubricant flow through the bearing.

## Vacuum pumps

High Load Capacity Deep Groove Ball Bearings



NSKHPS Angular Contact Ball Bearings, or High Load Capacity Double-row Angular Contact Ball Bearings

## Pumps for petroleum and chemicals

NSKHPS Angular Contact Ball Bearings

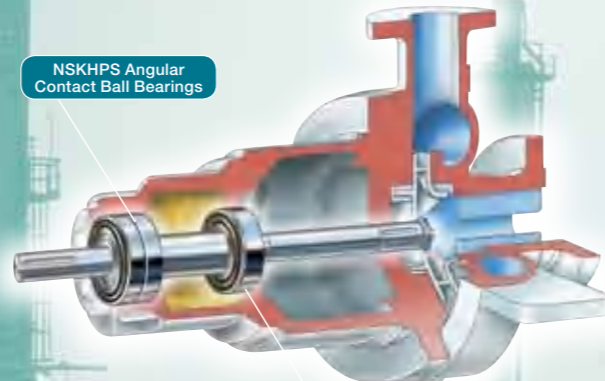

High Load Capacity Deep Groove Ball Bearings

## Slurry pumps

NSKHPS Angular Contact Ball Bearings

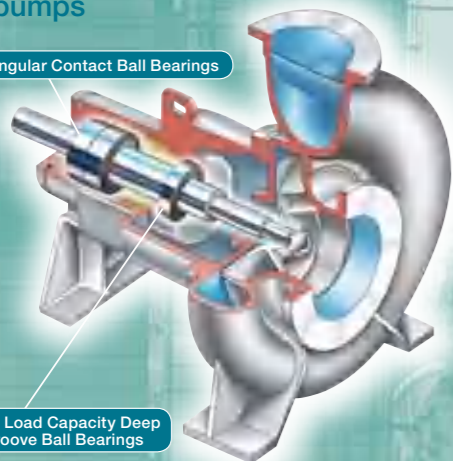

High Load Capacity Deep Groove Ball Bearings

## General pumps

High Load Capacity Deep Groove Ball Bearings

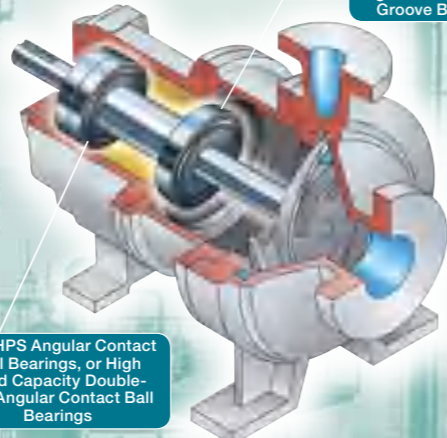

NSKHPS Angular Contact Ball Bearings, or High Load Capacity Double-row Angular Contact Ball Bearings

## Submerged pumps

Creep-free Bearings

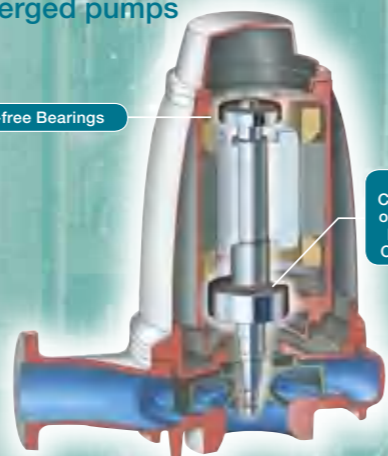

NSKHPS Angular Contact Ball Bearings, or High Load Capacity Double-row Angular Contact Ball Bearings

## Features of Bearings for Pumps



### NSKHPS angular contact ball bearings (machined brass cage)

- High load capacity angular contact ball bearings, adopting machined brass cages
- Improved bearing life up to 90% longer than conventional bearings reduces maintenance frequency and improves reliability.



### High load capacity double-row angular contact ball bearings

- High load capacity double-row angular contact ball bearings have advanced internal bearing geometry.
- Improved bearing life up to 50% longer than conventional bearings reduces maintenance frequency and improves reliability.



### High load capacity deep groove ball bearings (open type)

- Open-type high load capacity deep groove ball bearings have advanced internal bearing geometry.
- Improved bearing life up to 70% longer than conventional bearings reduces maintenance frequency and improves reliability.

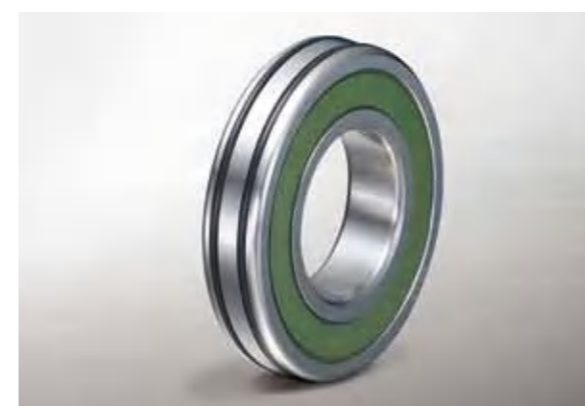

### Creep-free bearings

- Outer ring creep prevention is significantly improved with O-ring tension in the housing.
- Standard principal dimensions are maintained to eliminate the head for re-machining housings. Suitable as a bearing on the free side of motor-integrated pumps.

## NSKHPS Angular Contact Ball Bearings (machined brass cage)

- Application
- Petroleum and Chemical industry (API standards<sup>\*1</sup>, etc.)
  - Paper and Pulp industry (ANSI standards<sup>\*2</sup>, etc.)

<sup>\*1</sup> Standards related to petroleum specified by the American Petroleum Institute  
<sup>\*2</sup> Standards of industrial products in the U.S. specified by the American National Standards Institute

**High load capacity and outstanding lubrication performance.**  
**Enables reduced pump size and extended maintenance intervals.**

- Bearing life: 90% longer
- Maximum rotational speed: 20% faster
- Universal arrangement as standard
- 40° contact angle

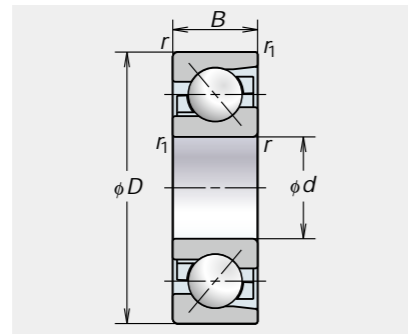

### Bearing nomenclature

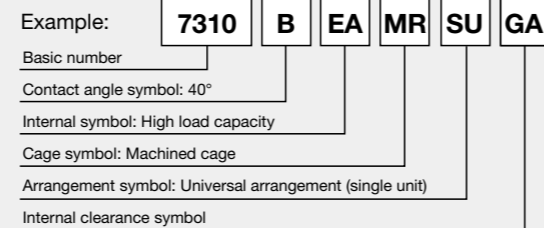

Axial internal clearance Unit: μm

Nominal bore diameter d (mm)		CNB		GA	
Over	Incl.	Min.	Max.	Min.	Max.
12	18	17	25	-2	6
18	30	20	28		
30	50	24	32		
50	80	29	41		
				-3	9

Bearing number	Boundary dimensions (mm)					Basic load rating (N)		Maximum rotational speed (min <sup>-1</sup> )
	d	D	B	r (min.)	r <sub>1</sub> (min.)	C <sub>r</sub> (dynamic)	C <sub>0r</sub> (static)	Oil
7201BEA	12	32	10	0.6	0.3	8 150	3 750	30 000
7301BEA	12	37	12	1	0.6	11 100	4 950	26 000
7202BEA	15	35	11	0.6	0.3	9 800	4 800	26 000
7302BEA	15	42	13	1	0.6	14 300	6 900	22 000
7203BEA	17	40	12	0.6	0.3	11 600	6 100	22 000
7303BEA	17	47	14	1	0.6	16 800	8 300	20 000
7204BEA	20	47	14	1	0.6	15 600	8 150	19 000
7304BEA	20	52	15	1.1	0.6	19 800	10 500	18 000
7205BEA	25	52	15	1	0.6	17 600	10 200	17 000
7305BEA	25	62	17	1.1	0.6	27 200	14 900	15 000
7206BEA	30	62	16	1	0.6	23 700	14 300	14 000
7306BEA	30	72	19	1.1	0.6	36 500	20 600	13 000
7207BEA	35	72	17	1.1	0.6	32 500	19 600	12 000
7307BEA	35	80	21	1.5	1	40 500	24 400	11 000
7208BEA	40	80	18	1.1	0.6	38 500	24 500	11 000
7308BEA	40	90	23	1.5	1	53 000	33 000	10 000
7209BEA	45	85	19	1.1	0.6	40 500	27 100	10 000
7309BEA	45	100	25	1.5	1	62 500	39 500	9 000
7210BEA	50	90	20	1.1	0.6	42 000	29 700	9 500
7310BEA	50	110	27	2	1	78 000	50 500	8 000
7211BEA	55	100	21	1.5	1	51 500	37 000	8 500
7311BEA	55	120	29	2	1	89 000	58 500	7 500
7212BEA	60	110	22	1.5	1	61 500	45 000	7 500
7312BEA	60	130	31	2.1	1.1	102 000	68 500	6 700
7213BEA	65	120	23	1.5	1	70 000	53 500	7 100
7313BEA	65	140	33	2.1	1.1	114 000	77 000	6 300
7214BEA	70	125	24	1.5	1	75 500	58 500	6 700
7314BEA	70	150	35	2.1	1.1	124 000	87 500	6 000
7215BEA	75	130	25	1.5	1	78 500	63 500	6 300
7216BEA	80	140	26	2	1	87 500	70 000	6 000

## High Load Capacity Double-row Angular Contact Ball Bearings

- Application
- Paper and Pulp industry (ANSI standards, etc.)
  - Water/Sewage and Irrigation, etc.

**Improved bearing life and thrust load capacity.**  
**Enables reduced pump size and extended maintenance intervals.**

- Bearing life: 50% longer
- Thrust load capacity: Twice as high as conventional bearings
- Improved installation with advanced lead in chamfer
- Class P6 as standard

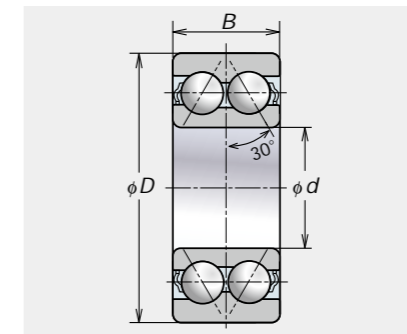

### Bearing nomenclature

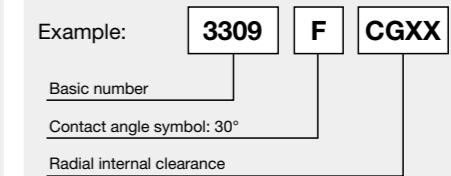

Bearing number	Boundary dimensions (mm)			Basic load rating (N)	
	d	D	B	C <sub>r</sub> (dynamic)	C <sub>0r</sub> (static)
3305F	25	62	25.4	30 500	20 500
3306F	30	72	30.2	39 500	27 300
3307F	35	80	34.9	49 500	35 000
3308F	40	90	36.5	60 500	44 000
3309F	45	100	39.7	66 500	49 500
3310F	50	110	44.4	85 500	64 500
3311F	55	120	49.2	106 000	82 000
3312F	60	130	54	122 000	95 500
3313F	65	140	58.7	138 000	109 000

## High Load Capacity Deep Groove Ball Bearings (open type)

- Application
- Petroleum and Chemical industry (API standards, etc.)
  - Paper and Pulp industry (ANSI standards, etc.)
  - Semi-conductor and Liquid Crystal Panel (vacuum pumps)

**High load capacity.**  
Enables reduced pump size and extended maintenance intervals.

- Bearing life: 70% longer

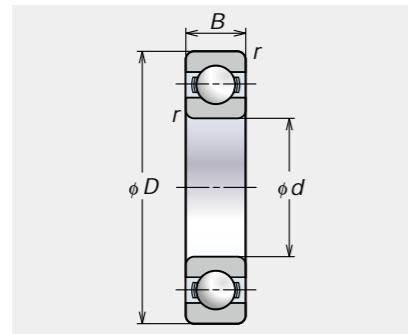

### Bearing nomenclature

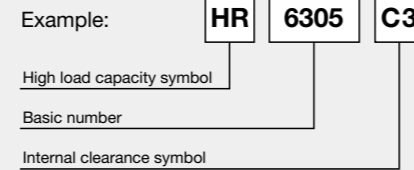

Bearing number	Boundary dimensions (mm)				Basic load rating (N)	
	d	D	B	r (min.)	C <sub>r</sub> (dynamic)	C <sub>0r</sub> (static)
HR 6202	15	35	11	0.6	8 550	3 950
HR 6302	15	42	13	1.0	13 300	5 900
HR 6203	17	40	12	0.6	11 300	5 350
HR 6303	17	47	14	1.0	15 600	7 100
HR 6304	20	52	15	1.1	18 200	9 050
HR 6205	25	52	15	1.0	15 300	8 100
HR 6305	25	62	17	1.1	23 700	12 200
HR 6206	30	62	16	1.0	23 300	12 800
HR 6306	30	72	19	1.1	29 800	15 800
HR 6207	35	72	17	1.1	28 300	16 000
HR 6307	35	80	21	1.5	39 500	21 500
HR 6208	40	80	18	1.1	32 500	19 900
HR 6308	40	90	23	1.5	47 000	26 200
HR 6209	45	85	19	1.1	36 500	22 600
HR 6309	45	100	25	1.5	57 000	34 500
HR 6210	50	90	20	1.1	39 000	25 800
HR 6310	50	110	27	2.0	66 500	40 500
HR 6211	55	100	21	1.5	48 000	32 000
HR 6311	55	120	29	2.0	78 000	46 000
HR 6212	60	110	22	1.5	58 000	38 000

## Creep-free Bearings

- Application
- Water/Sewage and Irrigation, etc.

**Outer ring creep prevention is significantly improved with O-ring tension in the housing.**  
Standard principal dimensions are maintained to eliminate the need for re-machining housings, providing a convenient solution to reduce costs.

(Recommended fits: G6 or H7)

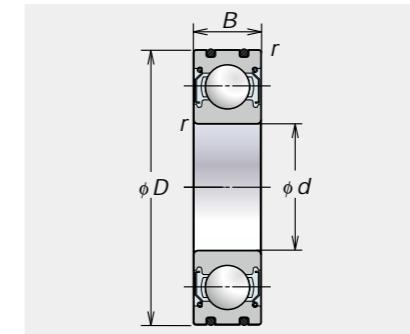
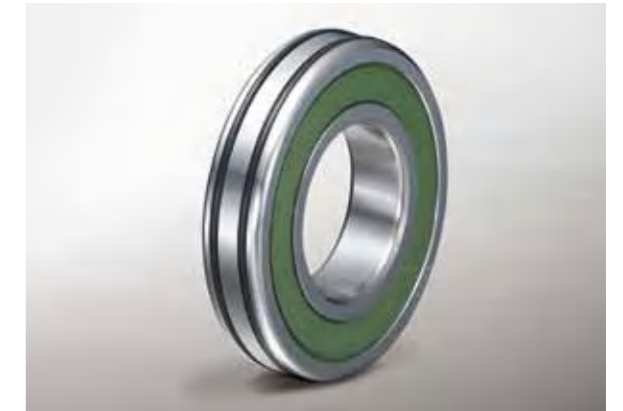

Bearing number	Boundary dimensions (mm)				Basic load rating (N)	
	d	D	B	r (min.)	C <sub>r</sub> (dynamic)	C <sub>0r</sub> (static)
6000	10	26	8	0.3	4 550	1 970
6200	10	30	9	0.6	5 100	2 390
6300	10	35	11	0.6	8 100	3 450
6001	12	28	8	0.3	5 100	2 370
6201	12	32	10	0.6	6 800	3 050
6301	12	37	12	1.0	9 700	4 200
6002	15	32	9	0.3	5 600	2 830
6202	15	35	11	0.6	7 650	3 750
6302	15	42	13	1.0	11 400	5 450
6003	17	35	10	0.3	6 000	3 250
6203	17	40	12	0.6	9 550	4 800
6303	17	47	14	1.0	13 600	6 650
6004	20	42	12	0.6	9 400	5 000
6204	20	47	14	1.0	12 800	6 600
6304	20	52	15	1.1	15 900	7 900
6005	25	47	12	0.6	10 100	5 850
6205	25	52	15	1.0	14 000	7 850
6305	25	62	17	1.1	20 600	11 200
6006	30	55	13	1.0	13 200	8 300
6206	30	62	16	1.0	19 500	11 300
6306	30	72	19	1.1	26 700	15 000
6007	35	62	14	1.0	16 000	10 300
6207	35	72	17	1.1	25 700	15 300
6307	35	80	21	1.5	33 500	19 200
6008	40	68	15	1.0	16 800	11 500
6208	40	80	18	1.1	29 100	17 900
6308	40	90	23	1.5	40 500	24 000
6009	45	75	16	1.0	20 900	15 200
6209	45	85	19	1.1	31 500	20 400
6309	45	100	25	1.5	53 000	32 000

# Bearing technologies for Compressors

Featuring bearing technologies that help to NSK bearings deliver superior performance

resist chemicals, oils, and heat, and life in adverse environments.

Long life reduces operating costs

With optimized internal design and unique material technology, NSK angular contact ball bearings improve operating life up to 90% longer than conventional bearings, and NSK cylindrical roller bearings deliver up to 50% longer life. This reduces operating costs and supports efficient design.

Outstanding reliability and environmental performance

NSK bearings conserve resources by improving efficiency and target zero environmental impact from harmful substances. In addition, NSK bearings help machines exhibit low vibration, low noise, and low dust for outstanding reliability while being easy and safe to operate.

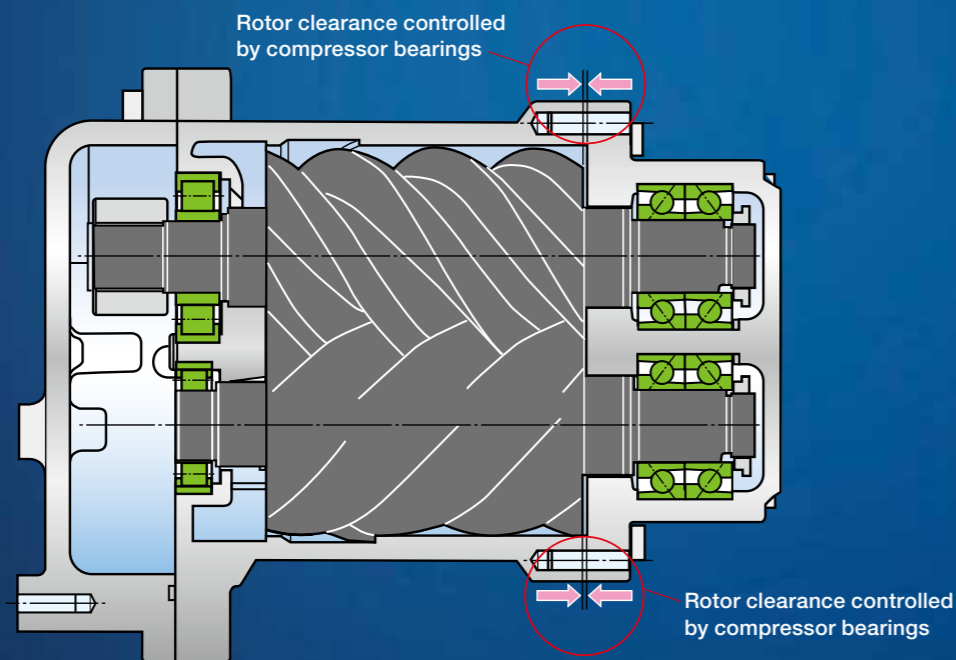

Material	Nylon 66	Nylon 46	L-PPS
Features	<ul style="list-style-type: none"> <li>Standard cage material</li> </ul>	<ul style="list-style-type: none"> <li>Superior high temperature strength</li> <li>Excellent heat resistance</li> </ul>	<ul style="list-style-type: none"> <li>Greater heat resistance than Nylon 46</li> <li>Excellent resistance to oil and chemicals</li> <li>Abrasion resistant</li> <li>Good dimensional stability</li> </ul>
Standard grade	Fiberglass-reinforced	Fiberglass-reinforced	Fiberglass-reinforced
Melting point	262°C	290°C	280°C

## L-PPS Bearings for Industrial Compressors

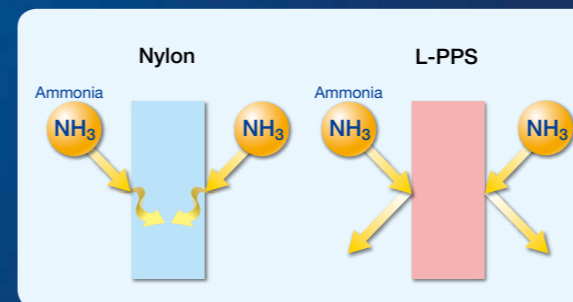

### Abrasion resistance of L-PPS

• Nylon 66, L-PPS, Machined brass

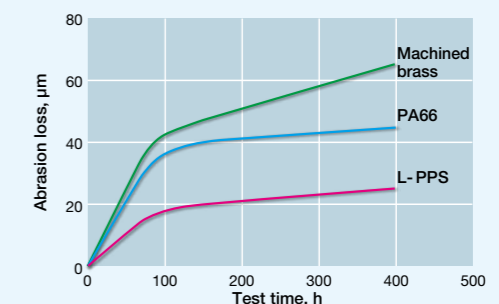

Plastic abrasion loss tends to saturate sooner than brass. L-PPS plastic features better abrasion resistance than PA66.

Load: 980 N  
 Rotational speed: 220 min<sup>-1</sup>  
 Counter material dimensions:  
 Outer diameter 25.6 mm  
 End face radius 185 mm  
 Spherical surface shape  
 Counter material: Bearing steel (HRC64)  
 Oil used: VG68

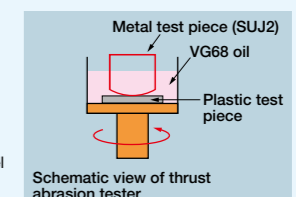

### High performance cage

• Nylon 66, L-PPS

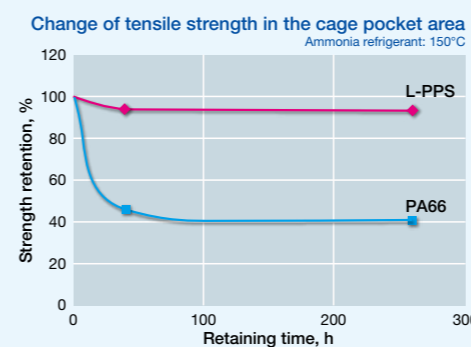

# Bearings for Compressors

L-PPS (Linear-Polyphenylene Sulfide) cages are chemically stable and resist wear better than steel or brass. Optimized internal geometries allow efficient lubricant flow through the bearing.

Compressors for refrigeration and air conditioning

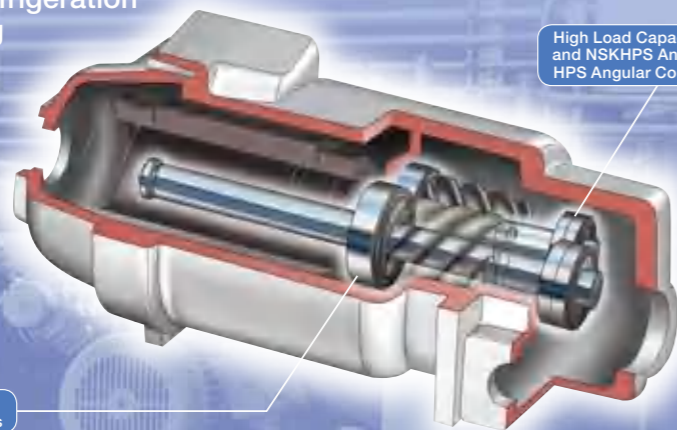

High Load Capacity Cylindrical Roller Bearings and NSKHPS Angular Contact Ball Bearings, or HPS Angular Contact Ball Bearings (combined)

High Load Capacity Cylindrical Roller Bearings

Oil-free screw compressors

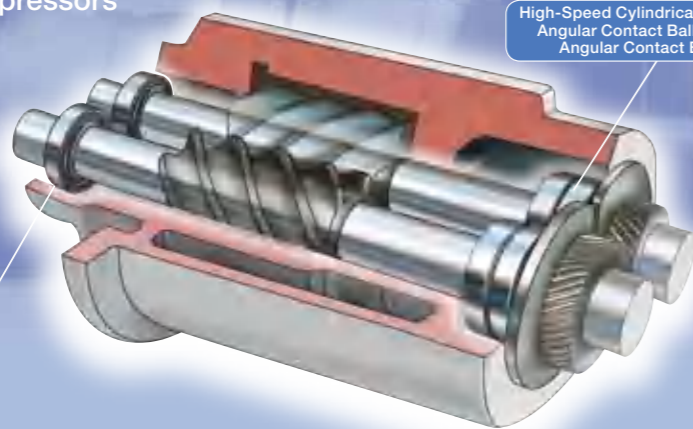

High-Speed Cylindrical Roller Bearings, High-Speed Angular Contact Ball Bearings, and High-Speed Angular Contact Ball Bearings (combined)

High-Speed Cylindrical Roller Bearings

Scroll compressors

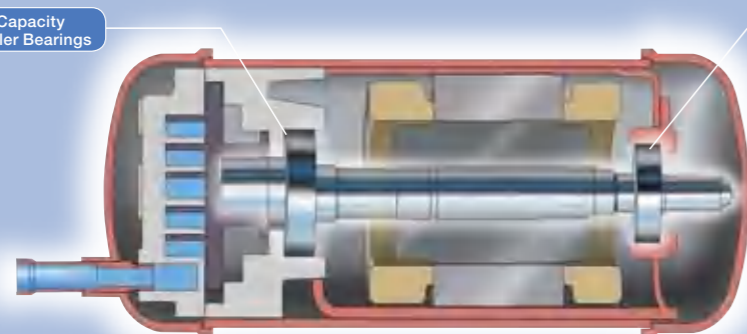

High Load Capacity Cylindrical Roller Bearings

Deep Groove Ball Bearings

## Features of Bearings for Compressors



### High load capacity cylindrical roller bearings (L-PPS cage)

- High load capacity cylindrical roller bearings, adopting high performance L-PPS plastic cages
- Heat-resistant L-PPS plastic cage delivers chemical stability that ensures strength with little to no deterioration, even in compressor oil, refrigeration machine oil, or ammonia refrigerant, while also providing excellent abrasion resistance.



### NSKHPS angular contact ball bearings (L-PPS cage)

- High load capacity angular contact ball bearings, adopting high performance L-PPS plastic cages
- Improved bearing life up to 90% longer than conventional bearings reduces maintenance frequency and improves reliability.



### High-speed cylindrical roller bearings

- High-speed cylindrical roller bearings, adopting outer-ring guided machined brass cages.
- Class P5 tolerances as standard bearing precision ensure stable performance at high speeds.



### High-speed angular contact ball bearings

- High-speed angular contact ball bearings, adopting outer-ring guided machined brass cages.
- Class P5 tolerances as standard bearing precision ensures stable performance at high speeds.

## High Load Capacity Cylindrical Roller Bearings (L-PPS cage)

- Application
- Refrigeration and air conditioning screw compressors
  - Air and gas screw compressors

**Outstanding load capacity and lubrication performance—allowing for reduced compressor size and extended maintenance intervals.**



Radial internal clearance Unit:  $\mu\text{m}$

Nominal bore diameter $d$ (mm)		Interchangeable CN clearance		Non-interchangeable CC clearance	
Over	Incl.	Min.	Max.	Min.	Max.
10	24	20	45	20	30
24	30	20	45	25	35
30	40	25	50	25	40
40	50	30	60	30	45
50	65	40	70	35	50
65	80	40	75	40	60
80	100	50	85	45	70

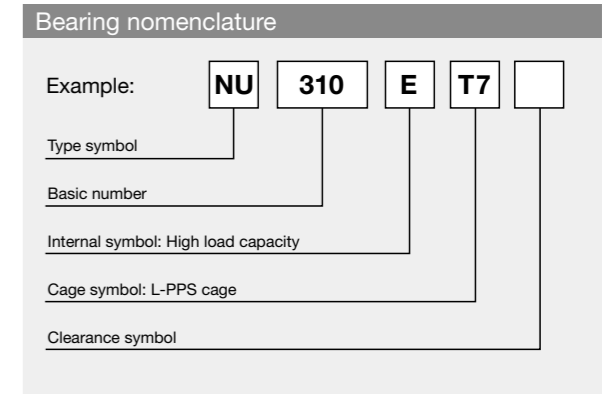
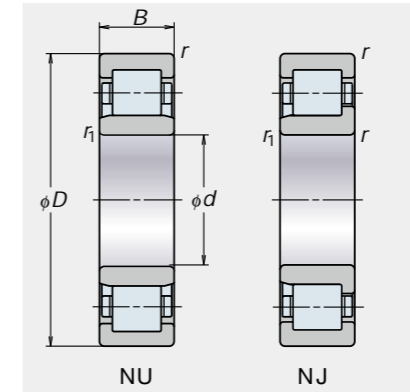

Bearing number	Boundary dimensions (mm)					Basic load rating (N)	
	$d$	$D$	$B$	$r$ (min.)	$r_1$ (min.)	$C_r$ (dynamic)	$C_{or}$ (static)
NU (NJ) 204ET7	20	47	14	1	0.6	25 700	22 600
NU (NJ) 304ET7	20	52	15	1.1	0.6	31 500	26 900
NU (NJ) 2204ET7	20	47	18	1	0.6	30 500	28 300
NU (NJ) 2304ET7	20	52	21	1.1	0.6	42 000	39 000
NU (NJ) 205ET7	25	52	15	1	0.6	29 300	27 700
NU (NJ) 305ET7	25	62	17	1.1	1.1	41 500	37 500
NU (NJ) 2205ET7	25	52	18	1	0.6	35 000	34 500
NU (NJ) 2305ET7	25	62	24	1.1	1.1	57 000	56 000
NU (NJ) 206ET7	30	62	16	1	0.6	39 000	37 500
NU (NJ) 306ET7	30	72	19	1.1	1.1	53 000	50 000
NU (NJ) 2206ET7	30	62	20	1	0.6	49 000	50 000
NU (NJ) 2306ET7	30	72	27	1.1	1.1	74 500	77 500
NU (NJ) 207ET7	35	72	17	1.1	0.6	50 500	50 000
NU (NJ) 307ET7	35	80	21	1.5	1.1	66 500	65 500
NU (NJ) 2207ET7	35	72	23	1.1	0.6	61 500	65 000
NU (NJ) 2307ET7	35	80	31	1.5	1.1	93 000	101 000
NU (NJ) 208ET7	40	80	18	1.1	1.1	55 500	55 500
NU (NJ) 308ET7	40	90	23	1.5	1.5	83 000	81 500
NU (NJ) 2208ET7	40	80	23	1.1	1.1	72 500	77 500
NU (NJ) 2308ET7	40	90	33	1.5	1.5	114 000	122 000
NU (NJ) 209ET7	45	85	19	1.1	1.1	63 000	66 500
NU (NJ) 309ET7	45	100	25	1.5	1.5	97 500	98 500
NU (NJ) 2209ET7	45	85	23	1.1	1.1	76 000	84 500
NU (NJ) 2309ET7	45	100	36	1.5	1.5	137 000	153 000
NU (NJ) 210ET7	50	90	20	1.1	1.1	69 000	76 500
NU (NJ) 310ET7	50	110	27	2	2	110 000	113 000
NU (NJ) 2210ET7	50	90	23	1.1	1.1	86 500	97 000
NU (NJ) 2310ET7	50	110	40	2	2	163 000	187 000
NU (NJ) 211ET7	55	100	21	1.5	1.1	86 500	98 500
NU (NJ) 311ET7	55	120	29	2	2	137 000	143 000
NU (NJ) 2211ET7	55	100	25	1.5	1.1	101 000	122 000

Bearing number	Boundary dimensions (mm)					Basic load rating (N)	
	$d$	$D$	$B$	$r$ (min.)	$r_1$ (min.)	$C_r$ (dynamic)	$C_{or}$ (static)
NU (NJ) 2311ET7	55	120	43	2	2	201 000	233 000
NU (NJ) 212ET7	60	110	22	1.5	1.5	97 500	107 000
NU (NJ) 312ET7	60	130	31	2.1	2.1	150 000	157 000
NU (NJ) 2212ET7	60	110	28	1.5	1.5	131 000	157 000
NU (NJ) 2312ET7	60	130	46	2.1	2.1	222 000	262 000
NU (NJ) 213ET7	65	120	23	1.5	1.5	108 000	119 000
NU (NJ) 313ET7	65	140	33	2.1	2.1	181 000	191 000
NU (NJ) 2213ET7	65	120	31	1.5	1.5	149 000	181 000
NU (NJ) 2313ET7	65	140	48	2.1	2.1	233 000	265 000
NU (NJ) 214ET7	70	125	24	1.5	1.5	119 000	137 000
NU (NJ) 314ET7	70	150	35	2.1	2.1	205 000	222 000
NU (NJ) 2214ET7	70	125	31	1.5	1.5	156 000	194 000
NU (NJ) 2314ET7	70	150	51	2.1	2.1	274 000	325 000
NU (NJ) 215ET7	75	130	25	1.5	1.5	130 000	156 000
NU (NJ) 315ET7	75	160	37	2.1	2.1	240 000	263 000
NU (NJ) 2215ET7	75	130	31	1.5	1.5	162 000	207 000
NU (NJ) 2315ET7	75	160	55	2.1	2.1	330 000	395 000
NU (NJ) 216ET7	80	140	26	2	2	139 000	167 000
NU (NJ) 316ET7	80	170	39	2.1	2.1	256 000	282 000
NU (NJ) 2216ET7	80	140	33	2	2	186 000	243 000
NU (NJ) 2316ET7	80	170	58	2.1	2.1	355 000	430 000
NU (NJ) 217ET7	85	150	28	2	2	167 000	199 000
NU (NJ) 2217ET7	85	150	36	2	2	217 000	279 000
NU (NJ) 2317ET7	85	180	60	3	3	395 000	485 000
NU (NJ) 218ET7	90	160	30	2	2	182 000	217 000
NU (NJ) 2218ET7	90	160	40	2	2	242 000	315 000
NU (NJ) 2318ET7	90	190	64	3	3	435 000	535 000
NU (NJ) 220ET7	100	180	34	2.1	2.1	310 000	305 000
NU (NJ) 320ET7	100	215	47	3	3	380 000	425 000
NU (NJ) 2220ET7	100	180	46	2.1	2.1	335 000	445 000
NU (NJ) 2320ET7	100	215	73	3	3	570 000	715 000

## NSKHPS Angular Contact Ball Bearings (L-PPS cage)

- Application
- Refrigeration and air conditioning screw compressors
  - Air and gas screw compressors

**Outstanding load capacity and lubrication performance—allowing for reduced compressor size and extended maintenance intervals.**

- Bearing life: up to 90% longer
- Maximum rotational speed: up to 20% faster
- Universal arrangement as standard
- 40° contact angle



Axial internal clearance Unit: μm

Nominal bore diameter $d$ (mm)		CNB		GA	
Over	Incl.	Min.	Max.	Min.	Max.
12	18	17	25	-2	6
18	30	20	28		
30	50	24	32		
50	80	29	41	-3	9

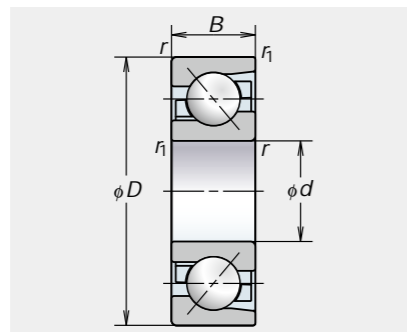

Bearing nomenclature

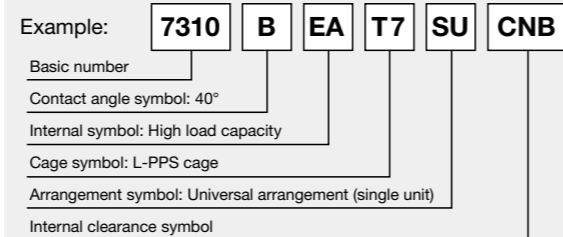

Bearing number	Boundary dimensions (mm)					Basic load rating (N)		Maximum rotational speed (min <sup>-1</sup> ) Oil
	$d$	$D$	$B$	$r$ (min.)	$r_1$ (min.)	$C_r$ (dynamic)	$C_{or}$ (static)	
7201BEA	12	32	10	0.6	0.3	8 150	3 750	30 000
7301BEA	12	37	12	1	0.6	11 100	4 950	26 000
7202BEA	15	35	11	0.6	0.3	9 800	4 800	26 000
7302BEA	15	42	13	1	0.6	14 300	6 900	22 000
7203BEA	17	40	12	0.6	0.3	11 600	6 100	22 000
7303BEA	17	47	14	1	0.6	16 800	8 300	20 000
7204BEA	20	47	14	1	0.6	15 600	8 150	19 000
7304BEA	20	52	15	1.1	0.6	19 800	10 500	18 000
7205BEA	25	52	15	1	0.6	17 600	10 200	17 000
7305BEA	25	62	17	1.1	0.6	27 200	14 900	15 000
7206BEA	30	62	16	1	0.6	23 700	14 300	14 000
7306BEA	30	72	19	1.1	0.6	36 500	20 600	13 000
7207BEA	35	72	17	1.1	0.6	32 500	19 600	12 000
7307BEA	35	80	21	1.5	1	40 500	24 400	11 000
7208BEA	40	80	18	1.1	0.6	38 500	24 500	11 000
7308BEA	40	90	23	1.5	1	53 000	33 000	10 000
7209BEA	45	85	19	1.1	0.6	40 500	27 100	10 000
7309BEA	45	100	25	1.5	1	62 500	39 500	9 000
7210BEA	50	90	20	1.1	0.6	42 000	29 700	9 500
7310BEA	50	110	27	2	1	78 000	50 500	8 000
7211BEA	55	100	21	1.5	1	51 500	37 000	8 500
7311BEA	55	120	29	2	1	89 000	58 500	7 500
7212BEA	60	110	22	1.5	1	61 500	45 000	7 500
7312BEA	60	130	31	2.1	1.1	102 000	68 500	6 700
7213BEA	65	120	23	1.5	1	70 000	53 500	7 100
7313BEA	65	140	33	2.1	1.1	114 000	77 000	6 300
7214BEA	70	125	24	1.5	1	75 500	58 500	6 700
7314BEA	70	150	35	2.1	1.1	124 000	87 500	6 000
7215BEA	75	130	25	1.5	1	78 500	63 500	6 300
7216BEA	80	140	26	2	1	87 500	70 000	6 000

## High-speed Cylindrical Roller Bearings

- Application
- Air (oil-free) screw compressors

**High-speed cylindrical roller bearings, adopting outer-ring guided machined brass cages.  $d_{mn}: 1\ 300\ 000$  (See Remarks 1 & 2) Bearing accuracy of more than Class P5 as standard.**

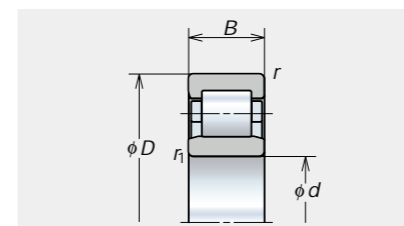

Bearing number	Boundary dimensions (mm)					Basic load rating (N)	
	$d$	$D$	$B$	$r$ (min.)	$r_1$ (min.)	$C_r$ (dynamic)	$C_{or}$ (static)
NU205EMM	25	52	15	1	0.6	29 300	27 700
NU206EMM	30	62	16	1	0.6	39 000	37 500
NU207EMM	35	72	17	1.1	0.6	50 500	50 000
NU208EMM	40	80	18	1.1	1.1	55 500	55 500
NU209EMM	45	85	19	1.1	1.1	63 000	66 500
NU210EMM	50	90	20	1.1	1.1	69 000	76 500

Remarks 1: Under general forced-lubrication condition  
Remarks 2: Contact NSK for maximum rotational speed, which can vary according to service conditions, and lubricating system.

## High-speed Angular Contact Ball Bearings

- Application
- Air (oil-free) screw compressors

**High-speed angular contact bearings, adopting outer-ring guided machined brass cages.  $d_{mn}: 1\ 300\ 000$  (See Remarks 1 & 2) Bearing accuracy of more than Class P5 as standard.**

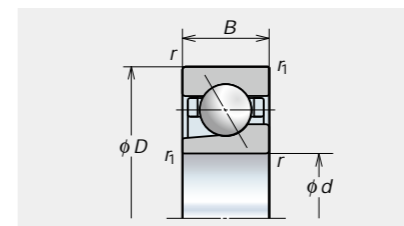

Bearing number	Boundary dimensions (mm)					Basic load rating (N)	
	$d$	$D$	$B$	$r$ (min.)	$r_1$ (min.)	$C_r$ (dynamic)	$C_{or}$ (static)
20BA02A	20	47	14	1	0.6	13 600	7 550
25BA02A	25	52	15	1	0.6	15 400	9 500
30BA03B	30	72	19	1.5	0.6	31 500	19 000
35BA03B	35	80	21	1.5	0.6	39 000	24 000
40BA02A	40	80	18	1.5	0.6	34 500	24 100
45BA03A2	45	100	25	1.5	1	60 000	40 000
50BA03A1	50	110	27	1	2.5	70 000	47 500

Remarks 1: Under general forced-lubrication condition  
Remarks 2: Contact NSK for maximum rotational speed, which can vary according to service conditions, and lubricating system.

## Worldwide Sales Offices

<b>NSK LTD.-HEADQUARTERS, TOKYO, JAPAN</b> <a href="http://www.nsk.com">www.nsk.com</a> INDUSTRIAL MACHINERY BUSINESS DIVISION-HEADQUARTERS tel: 03-3779-7227 GLOBAL AFTERMARKET DEPARTMENT tel: 03-3779-7253 PRECISION MACHINERY DEPARTMENT tel: 03-3779-7163 MECHATRONICS BUSINESS DEPARTMENT tel: 0466-21-3027 AUTOMOTIVE BUSINESS DIVISION-HEADQUARTERS tel: 03-3779-7189	<b>Indonesia:</b> <b>PT. NSK INDONESIA</b> Jakarta tel: 021-252-3458 <b>Korea:</b> <b>NSK KOREA CO., LTD.</b> Seoul tel: 02-3287-0300 Changwon tel: 055-287-6001 <b>Malaysia:</b> <b>NSK BEARINGS (MALAYSIA) SDN.BHD.</b> <a href="http://www.my.nsk.com">www.my.nsk.com</a> Shah Alam tel: 03-7803-8859 <b>New Zealand:</b> <b>NSK NEW ZEALAND LTD.</b> <a href="http://www.nsk-rhp.co.nz">www.nsk-rhp.co.nz</a> Auckland tel: 09-276-4992 <b>Philippines:</b> <b>NSK REPRESENTATIVE OFFICE</b> Manila tel: 02-893-9543 <b>Singapore:</b> <b>NSK INTERNATIONAL (SINGAPORE) PTE LTD.</b> Singapore tel: 6496-8000 <b>NSK SINGAPORE (PRIVATE) LTD.</b> <a href="http://www.nsk-singapore.com.sg">www.nsk-singapore.com.sg</a> Singapore tel: 6496-8000 <b>Taiwan:</b> <b>TAIWAN NSK PRECISION CO., LTD.</b> Taipei tel: 02-2509-3305 <b>TAIWAN NSK TECHNOLOGY CO., LTD.</b> Taipei tel: 02-2509-3305 <b>Thailand:</b> <b>NSK BEARINGS (THAILAND) CO., LTD.</b> Bangkok tel: 02320-2555 <b>SIAM NSK STEERING SYSTEMS CO., LTD.</b> Chachoengsao tel: 038-522-343 <b>NSK ASIA PACIFIC TECHNOLOGY CENTER (THAILAND) CO., LTD.</b> Chonburi tel: 038-454-631 <b>Vietnam:</b> <b>NSK VIETNAM CO., LTD.</b> Hanoi tel: 04-3955-0159 <b>NSK REPRESENTATIVE OFFICE</b> Ho Chi Minh City tel: 08-3822-7907 <b>Europe</b> <b>NSK EUROPE LTD. (EUROPEAN HEADQUARTERS)</b> <a href="http://www.eu.nsk.com">www.eu.nsk.com</a> Maidenhead tel: 01628-509-800 <b>France:</b> <b>NSK FRANCE S.A.S.</b> Paris tel: 01-30-57-39-39 <b>Germany:</b> <b>NSK DEUTSCHLAND GMBH</b> Düsseldorf tel: 02102-4810 <b>NSK PRECISION EUROPE GMBH</b> Düsseldorf tel: 02102-4810 <b>Italy:</b> <b>NSK ITALIA S.P.A.</b> Milano tel: 0299-5191	<b>Poland:</b> <b>NSK EUROPE LTD. WARSAW LIAISON OFFICE</b> Warsaw tel: 022-645-1525 <b>NSK EUROPEAN TECHNOLOGY CENTER, POLAND OFFICE</b> Kielce tel: 041-367-0940 <b>NSK STEERING SYSTEMS EUROPE (POLSKA) SP.ZO.O.</b> Walbrzych tel: 074-664-4101 <b>NSK NEEDLE BEARING POLAND SP.ZO.O.</b> Kielce tel: 041-345-2469 <b>NSK POLSKA SP.ZO.O.</b> Kielce tel: 041-347-5110 <b>Spain:</b> <b>NSK SPAIN S.A.</b> Barcelona tel: 093-433-5775 <b>Turkey:</b> <b>NSK RULMANLARI ORTA DOGU TIC. LTD. STI.</b> Istanbul tel: 0216-355-0398 <b>United Kingdom:</b> <b>NSK EUROPEAN TECHNOLOGY CENTRE</b> Newark tel: 01636-605-123 <b>NSK UK Ltd.</b> Newark tel: 01636-605-123 <b>NSK PRECISION UK LTD.</b> Newark tel: 01636-605-123 <b>NSK STEERING SYSTEMS EUROPE LTD.</b> Maidenhead tel: 01628-509-800 <b>North and South America</b> <b>NSK AMERICAS, INC. (AMERICAN HEADQUARTERS)</b> Ann Arbor tel: 734-913-7500 <b>Argentina:</b> <b>NSK ARGENTINA SRL</b> Buenos Aires tel: 11-4704-5100 <b>Brazil:</b> <b>NSK BRASIL LTDA.</b> <a href="http://www.br.nsk.com">www.br.nsk.com</a> São Paulo tel: 011-3269-4786 <b>Canada:</b> <b>NSK CANADA INC.</b> <a href="http://www.ca.nsk.com">www.ca.nsk.com</a> Toronto tel: 905-890-0740 <b>Mexico:</b> <b>NSK RODAMIENTOS MEXICANA, S.A. DE C.V.</b> <a href="http://www.mx.nsk.com">www.mx.nsk.com</a> Mexico City tel: 55-3682-2900 <b>United States of America:</b> <b>NSK CORPORATION</b> <a href="http://www.us.nsk.com">www.us.nsk.com</a> Ann Arbor tel: 734-913-7500 <b>NSK AMERICAN TECHNOLOGY CENTER</b> Ann Arbor tel: 734-913-7500 <b>NSK PRECISION AMERICA, INC.</b> <a href="http://www.npa.nsk.com">www.npa.nsk.com</a> Franklin tel: 317-738-5000 <b>NSK STEERING SYSTEMS AMERICA, INC.</b> <a href="http://www.nssa.nsk.com">www.nssa.nsk.com</a> Bennington tel: 802-442-5448 <b>NSK LATIN AMERICA, INC.</b> <a href="http://www.la.nsk.com">www.la.nsk.com</a> Miami tel: 305-477-0605
<b>Africa</b> <b>South Africa:</b> <b>NSK SOUTH AFRICA (PTY) LTD.</b> Johannesburg tel: 011-458-3600 <b>Asia and Oceania</b> <b>Australia:</b> <b>NSK AUSTRALIA PTY. LTD.</b> <a href="http://www.au.nsk.com">www.au.nsk.com</a> Melbourne tel: 03-9764-8302 <b>China:</b> <b>NSK HONG KONG LTD.</b> Hong Kong tel: 02739-9933 Shenzhen tel: 0755-25904886 <b>KUNSHAN NSK CO., LTD.</b> Kunshan tel: 0512-5771-5654 <b>CHANGSHU NSK NEEDLE BEARING CO., LTD.</b> Jiangsu tel: 0512-5230-1111 <b>NSK STEERING SYSTEMS DONGGUAN CO., LTD.</b> Dongguan tel: 0769-2262-0960 <b>NSK (CHINA) RESEARCH &amp; DEVELOPMENT CO., LTD.</b> Jiangsu tel: 0512-5796-3000 <b>NSK (SHANGHAI) TRADING CO., LTD.</b> Jiangsu tel: 0512-5796-3000 <b>NSK (CHINA) INVESTMENT CO., LTD.</b> Jiangsu tel: 0512-5796-3000 Beijing tel: 010-6590-8161 Guangzhou tel: 020-3786-4833 Chengdu tel: 028-8661-4200 Shenyang tel: 024-2334-2868 Dalian tel: 0411-8800-8168 <b>NSK CHINA SALES CO., LTD.</b> Jiangsu tel: 0512-5796-3000 Changchun tel: 0431-8898-8682 Tianjin tel: 022-8319-5030 Nanjing tel: 025-8472-6671 Chongqing tel: 023-6806-5310 <b>India:</b> <b>RANE NSK STEERING SYSTEMS LTD.</b> Chennai tel: 044-474-06017 <b>NSK INDIA SALES CO. PVT. LTD.</b> Chennai tel: 044-2433-1161 Gurgaon tel: 0124-4104-530 Kolkata tel: 033-4001-2062 Mumbai tel: 022-2838-7787 <b>NSK-ABC BEARINGS LTD.</b> Chennai tel: 044-2714-3000		

<As of July 2010>

For the latest information, please refer to the NSK website.

NSK Ltd. has a basic policy not to export any products or technology designated as controlled items by export-related laws. When exporting the products in this brochure, the laws of the exporting country must be observed. Specifications are subject to change without notice and without any obligation on the part of the manufacturer. Every care has been taken to ensure the accuracy of the data contained in this brochure, but no liability can be accepted for any loss or damage suffered through errors or omissions. We will gratefully acknowledge any additions or corrections.

For more information about NSK products, please contact: \_\_\_\_\_

